

TRAILBOSS

Tow bar Fitting Instructions To Suit Holden Rodeo LX 4x4 Turbo Diesel Without Factory Bumper step 01-07-on Part Number QTHD496L Rating 3000 kg Max Static Ball Load 300Kg

WARNING:

1. Do not, drill, cut, weld or otherwise modify the tow bar.
2. If you are using electric welding on a motor vehicle, **always** check that the vehicle is not equipped with electronic engine or instrument management equipment. Failure to do so could **destroy** any onboard computers. If in doubt, check with the vehicle's manufacturer.

General:

1. Ensure all hardware items have been included
2. It is recommended that the instructions are read through and completely understood before making any attempt to fit this product.
3. Be wary of any changes to vehicle designs or other accessories that may conflict with the installation of this product.
4. Before drilling ensure that the area is clear of fuel, electrical & other components.
5. All holes drilled into the body panels shall have all burrs & swarf removed then coated with a suitable rust preventative paint.
6. The high tensile fasteners supplied with this product were used to achieve the specified rating. If replacement is required ensure that fasteners of the same rating & quality are used. Contact an authorized **Trailboss** dealer if further information is required.
7. Ensure that all hardware is fastened to torque list below check fasteners on regular basis.
8. Tow bar load rating sticker provided with this product shall be conspicuously located on inside rear end of the driver's door. **(See diagram below).**
9. Trailboss recommends that you check your tow ball to ensure that it complies with the Australian standards **AS 4177.2**.
10. **PLEASE NOTE:** It is advised to remove your lug or tbn when not actually towing so as to produce a clear view of the vehicles registration plate if obscured, and to also provide maximum available departure angle

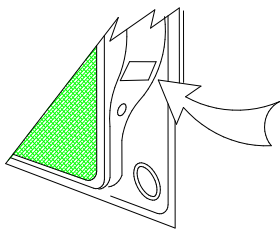

Place load rating sticker
inside driver's door here

FOR TOWING PURPOSES ONLY

For towing capacity details please refer to vehicle owner's manual or to the manufacturer. Overloading can void your warranties.

RECOMMENDED ASSEMBLY TORQUE LISTING

<u>Diameter</u>	<u>Grade 8.8 Bolt</u>
M6	9.5 Nm
M8	21.7 Nm
M10	43.4 Nm
M12	77.3 Nm
M16	189.8 Nm

Tow bar Maintenance and Care.

Trailboss recommends that bolt torque's, as listed below, are routinely and regularly inspected and checked for correct tension. Replace any worn or defective parts.

We recommended to remove Tow Ball Mounts (TBM's, tongues or lugs) when not being used for any considerable length of time.

So as to avoid injury, when not towing it is suggested that the tongue, Pull Pin and R-clip are removed then stored in a safe, clean and dry place, away from excessive moisture.

Hitch Pull Pins and spring "R" clips are regularly checked for proper installation. Replace any worn or defective parts.

Tow bar Fitting Instructions
To Suit Holden Rodeo LX 4x4 Turbo Diesel Without Factory Bumper step 01-07-on
Part Number QTHD496L
Rating 3000 kg Max Static Ball Load 300Kg

11. **It is recommended that this product be fitted on a hoist for ease of assembly (caution two person lift required).**

- a. Remove existing tow hook if fitted via 2 M10 bolts then discard for fitment of tow bar see fig 1.



12. **Fitment of tow bar via**

- a. Offer tow bar to chassis rails so that holes in side plates align with captive nuts on the side of chassis rails see fig 2.
- b. Fit M12 bolts with flat & spring washers loosely.
- c. Fit loose angle brackets with M10 bolts flat & spring washers & M10 nuts supplied.
- d. Once all hardware is fitted tighten all fasteners to torque listing on the first page.

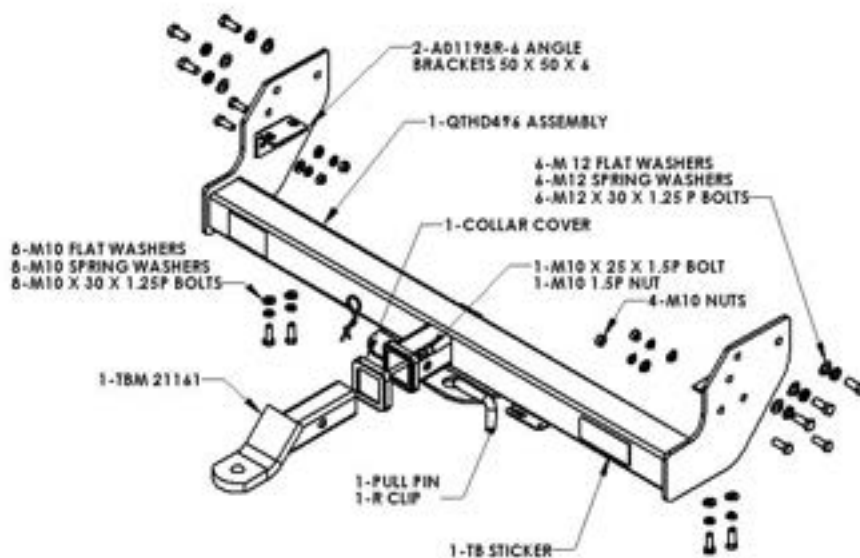
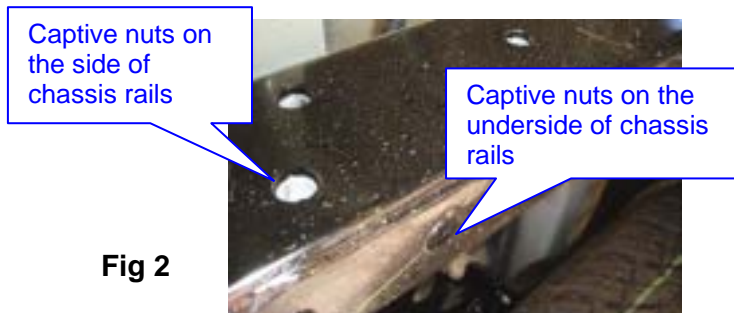



Wiring Loom Fitting Instructions
To Suit Holden Rodeo
Rodeo LT 4x4 Turbo Diesel
Rodeo LT 4x4 Turbo Diesel (2001 to 2007)
Rodeo 2WD & 4WD

Part Number 100055-WL

Wiring Loom Installation Instructions

Holden Rodeo
Part No: 100055-WL

Tail Harness Length Required: 1200mm
RPA Override Switch Part No: 04848 (If Fitted)

Wiring Loom Installation Time: Approx 20 Mins



Wiring Loom Fitting Instructions
To Suit Holden Rodeo
Rodeo LT 4x4 Turbo Diesel
Rodeo LT 4x4 Turbo Diesel (2001 to 2007)
Rodeo 2WD & 4WD

Part Number 100055-WL

1. Underneath the rear of the vehicle, locate and disconnect the LHS vehicle trailer break-out connector.
2. Secure the Tail Harness socket onto the towbar mounting bracket with fasteners.
3. Connect the Trailer Patch Harness (part no. 100055-WL) to the LHS break-out connector.
4. Route Tail Harness (length 1200mm) towards the Trailer Patch Harness and connect the Trailer Patch Harness to the Trailer tail Harness.
5. Secure the Trailer Patch Harness relays onto the interior vehicle sheet metal using tech screws. Secure the vehicle patch harness and Tail Harness connectors using cable ties (not supplied).
6. Test the Trailer socket using a light board or multi-meter.
7. Secure the all harnesses using cables ties (not supplied).
8. Refit all removed parts and secure all fasteners.
9. Place instructions in glove box after fitment.