

TRAILBOSS

Towbar Fitting Instructions

TO SUIT HOLDEN COMMODORE VY SEDAN & BERLINA SERIES 1 10/02 TO
08/04 VZ SEDAN 09/04 TO 07/06.

Part Number QTHD498L

Rating 2100Kg

1. Ensure all hardware items have been included.
2. Removal of rear bumper bar.
 - a. Remove four self taper screws from each wheel arch and mud flaps if fitted.
 - b. Remove two plastic trim buttons, attaching bumper to rear panel from under car.
 - c. Remove six plastic trim buttons from under weather seal of boot lid or tail gate.
 - d. Remove 4mm nuts, two each side, from inside boot behind rear quarter panel trim.
 - e. Remove bumper assembly by pulling outwards from wheel arch to release clips, then sliding rearward.
3. Remove impact beam. **NOTE: Tool required TORX T50 on some vehicles.**
4. Remove impact beam mounting brackets.
5. Fit towbar cross member to studs for impact beam.
6. Refit impact beam mounting brackets with original nut, flat washers and shake proof washers supplied. Tighten finger tight only.
7. Remove boot carpet and spare wheel.
8. Position towbar tail assembly under spare wheel well and align two tapped holes in centre with holes in cross member.
9. Fit two M12x30 1.25 bolts, spring washers and flat washers finger tight.
10. Using holes in tabs welded to cross member as guides, drill dia 11mm holes through panel into spare wheel well.
11. **Note: It may be necessary to use 40 x 6 x 40 packers supplied between towbar and rear panel, due to variation in vehicles.**
12. Position boot plate assemblies into spare wheel well and align with holes drilled in step 10.
13. **NOTE: Remove any sealant or body deadener material that may interfere with the correct fitment of plates.**
14. Fit two M10x35 bolts, spring washers, loose plates and nuts through holes drilled in step 10. Fit 6mm loose plate behind tab on driver's side. Tighten finger tight only.
15. Drill remaining holes in boot plates with an 11mm drill. **WARNING: Use a short bit or place a spacer tube over drill bit to avoid hitting fuel tank when drilling through.**
16. **NOTE: On passengers side do not drill lowest hole in formed section of plate. It is a location hole for manufacturing only.**
17. Fit loose plates and bolts as shown in diagram.
18. Tighten all bolts to torque listing below.
19. Fit fuel tank heat shield as shown in diagram.
20. Remove window insert and refit bumper bar.
21. Refit spare wheel, carpet and trim panels.
22. Tow bar load rating sticker provided with this product shall be conspicuously located on inside rear end of the driver's door. (See diagram below).

RECOMMENDED ASSEMBLY TORQUE LISTING

<u>Diameter</u>	<u>Grade 8.8 Bolt</u>
	<u>Nm</u>
M6	9.5
M8	21.7
M10	43.4
M12	77.3
M14	121.0
M16	189.8

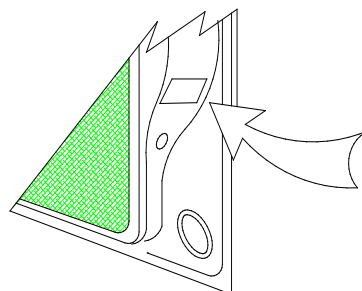

PLACE LOAD RATING
STICKER INSIDE DRIVERS
DOOR.

TRAILBOSS

Towbar Fitting Instructions
TO SUIT HOLDEN COMMODORE VY SEDAN & BERLINA SERIES 1 10/02 TO
08/04 VZ SEDAN 09/04 TO 07/06.

Part Number QTHD498L

Rating 2100Kg

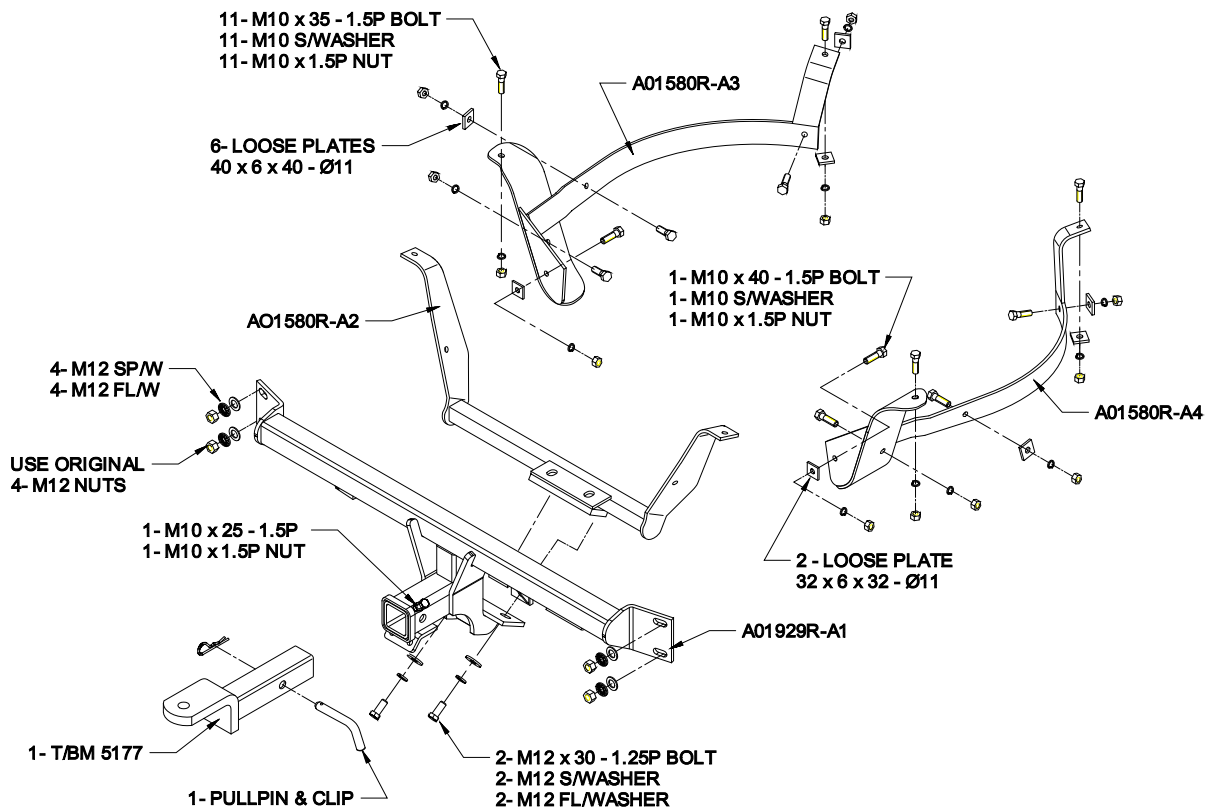

TRAILBOSS

Towbar Fitting Instructions
TO SUIT HOLDEN COMMODORE VY SEDAN & BERLINA SERIES 1 10/02 TO
08/04 VZ SEDAN 09/04 TO 07/06.

Part Number QTHD498L

Rating 2100Kg

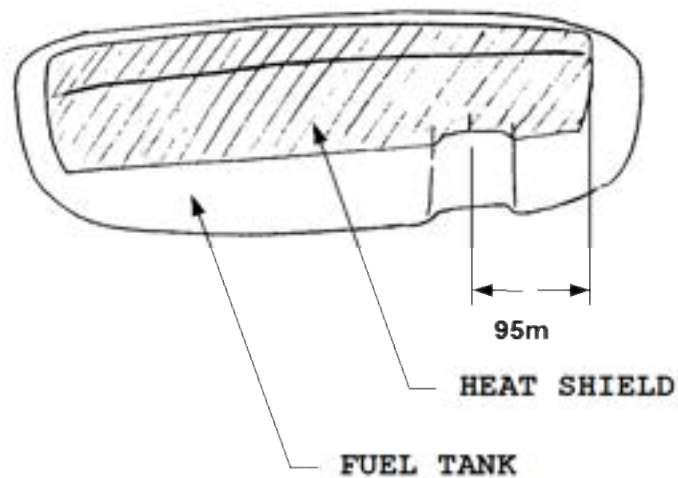
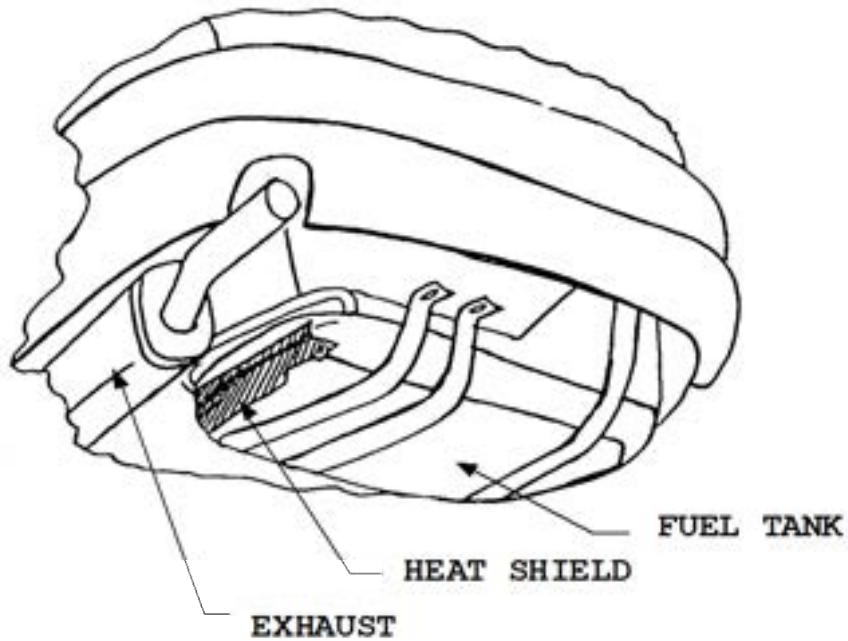



Wiring Loom Fitting Instructions
To Suit Holden VY Commodore Sedan & Wagon
Holden Statesman Sedan & Wagon

Part Number 100044-WL

Wiring Loom Installation Instructions

Holden VY Commodore Sedan & Wagon
Holden Statesman Sedan & Wagon

Part No: 100044-WL

Tail Harness Length Required: 1200mm

RPA Override Switch Part No: 04848 (If Fitted)

Wiring Loom Installation Time: Approx 20 Mins

TRAILBOSS

Wiring Loom Fitting Instructions To Suit Holden VY Commodore Sedan & Wagon Holden Statesman Sedan & Wagon

Part Number 100044-WL

Note: For Wagon models, go to step 13.

For VT, VX, VY and VZ sedan models, continue:

1. In the luggage compartment, remove all trims required to gain access to the tail lights.
2. Remove the rear bumper fascia fasteners and then remove the rear bumper fascia (1).
3. Drill a Ø30mm grommet hole into the location shown (2). File down any rough edges and spray on rust inhibitor.



4. Mount the Tail Harness socket (Tail length 1200mm) to the towbar mounting bracket using M4 fasteners.
5. Route the harness along the towbar and into the grommet hole.
6. In the luggage compartment, retrieve the Tail Harness.
7. Adjust the harness grommet to the desired position, ensuring that it is seated correctly into the vehicle grommet hole. Secure the vehicle grommet using a cable tie (not supplied).
8. On the outside of the vehicle, secure the harness to the towbar using cable ties (not supplied).
9. Disconnect the RHS tail light connectors and the 1-way indicator connector. Connect the Trailer Patch Harness (P/No: 100044-WL) in between the tail light connectors and the 1-way indicator connector.
10. Refit the rear bumper fascia.
11. Test the Trailer socket using a light board or multi-meter.
12. Secure the all harnesses using cables ties (not supplied). Refit all removed parts and secure all fasteners. Place instructions in glove box after fitment.



Wiring Loom Fitting Instructions
To Suit Holden VY Commodore Sedan & Wagon
Holden Statesman Sedan & Wagon

Part Number 100044-WL

The following steps for Wagon models only

13. Remove the rear bumper fascia.
14. Gain access to the tail lights.
15. Remove the tail light assembly.
16. Drill a Ø30mm hole into the rear tail gate, below the RHS tail light cavity opening. File down any rough edges and spray on rust inhibitor.
17. Mount the Tail Harness socket (Tail length 1200mm) to the towbar mounting bracket using M4 fasteners.
18. Route the Tail Harness along the towbar and into the grommet hole
19. Adjust the harness grommet to the desired position, ensuring that it is seated correctly into the vehicle grommet hole. Secure the vehicle grommet using a cable tie (not supplied).
20. Secure the harness to the towbar using cable ties (not supplied).
21. Disconnect the RHS tail light connectors and the 1-way indicator connector. Connect the Trailer Patch Harness (P/No: 100044-WL) in between the tail light connectors and the 1-way indicator connector
22. Connect the Tail Harness 8-way male connector to the Trailer Patch Harness 8-way female connector.
23. Test the Trailer Harness function using a Light Board or multimeter.
24. Secure the Trailer Patch Harness using cable ties (not supplied).
25. Refit all removed parts and secure all fasteners ensuring there are no squeaks or rattles.
26. Place instructions in glove box after fitment.