

TRAILBOSS

Towbar Fitting Instructions To Suit **HOLDEN TRAX 2013-ON** Part Number **QTHD520L** Rating **1200/120 kg**

PLACE THESE INSTRUCTIONS IN THE VEHICLE'S GLOVEBOX AFTER INSTALLATION IS COMPLETED

WARNING:

1. Do not, drill, cut, weld or otherwise modify the tow bar.
2. If you are using electric welding on a motor vehicle, **always** check that the vehicle is not equipped with electronic engine or instrument management equipment. Failure to do so could **destroy** any onboard computers. If in doubt, check with the vehicle's manufacturer.
3. The high tensile fasteners supplied with this product were used to achieve the specified rating. If replacement is required ensure that fasteners of the same rating & quality are used. Contact an authorised **Trailboss** dealer if further information is required.
4. If TBM is used in inverted position tow ball may make contact with rear tailgate when lowered, which could cause damage.

General:

1. Ensure all hardware items have been included refer to assembly diagram.
2. It is recommended that the instructions are read through and completely understood before making any attempt to fit this product.
3. Be wary of any changes to vehicle designs or other accessories that may conflict with the installation of this product.
4. Before drilling ensure that the area is clear of fuel, electrical & other components.
5. All holes drilled into the body panels shall have all burrs & swarf removed then coated with a suitable rust preventative paint.
6. For vehicles that require the bumper to be cut. Ensure cut out area is in correct position on the vehicle prior to cutting the bumper.
7. The high tensile fasteners supplied with this product were used to achieve the specified rating. If replacement is required ensure that fasteners of the same rating & quality are used. Contact an authorized **Trailboss** dealer if further information is required.
8. Ensure that all hardware is fastened to torque list below check fasteners on regular basis.
9. Tow bar load rating sticker provided with this product shall be conspicuously located on inside rear end of the driver's door. **(See diagram below).**
10. Trailboss recommends that you check your tow ball to ensure that it complies with the Australian standards **AS 4177.2**.
11. **PLEASE NOTE:** It is advised to remove your lug or tbn when not actually towing so as to produce a clear view of the vehicles registration plate if obscured, and to also provide maximum available departure angle
12. Pull Pin must be fit in down position.

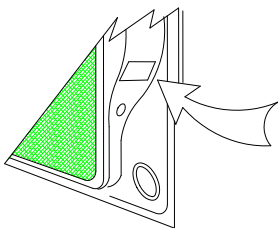

Place load rating sticker
inside driver's door here

FOR TRAILER TOWING PURPOSES ONLY
For towing capacity details please refer to vehicle owner's manual or to the manufacturer. Overloading can void your warranties.

RECOMMENDED ASSEMBLY TORQUE LISTING

<u>Diameter</u>	<u>Grade 8.8 Bolt</u>
M6	9.5 Nm
M8	21.7 Nm
M10	43.4 Nm
M12	77.3Nm
M14	146 Nm
M16	189.8 Nm

Tow bar Maintenance and Care.

Trailboss recommends that bolt torque's, as listed below, are routinely and regularly inspected and checked for correct tension. Replace any worn or defective parts.

We recommended to remove Tow Ball Mounts (TBM's, tongues or lugs) when not being used for any considerable length of time.

So as to avoid injury, when not towing it is suggested that the tongue, Pull Pin and R-clip are removed then stored in a safe, clean and dry place, away from excessive moisture.

Hitch Pull Pins and spring "R" clips are regularly checked for proper installation. Replace any worn or defective parts.

TRAILBOSS

Towbar Fitting Instructions
 To Suit **HOLDEN TRAX 2013-ON**
 Part Number **QTHD520L**
 Rating **1200/120 kg**

PLACE THESE INSTRUCTIONS IN THE VEHICLE'S GLOVEBOX AFTER INSTALLATION IS COMPLETED

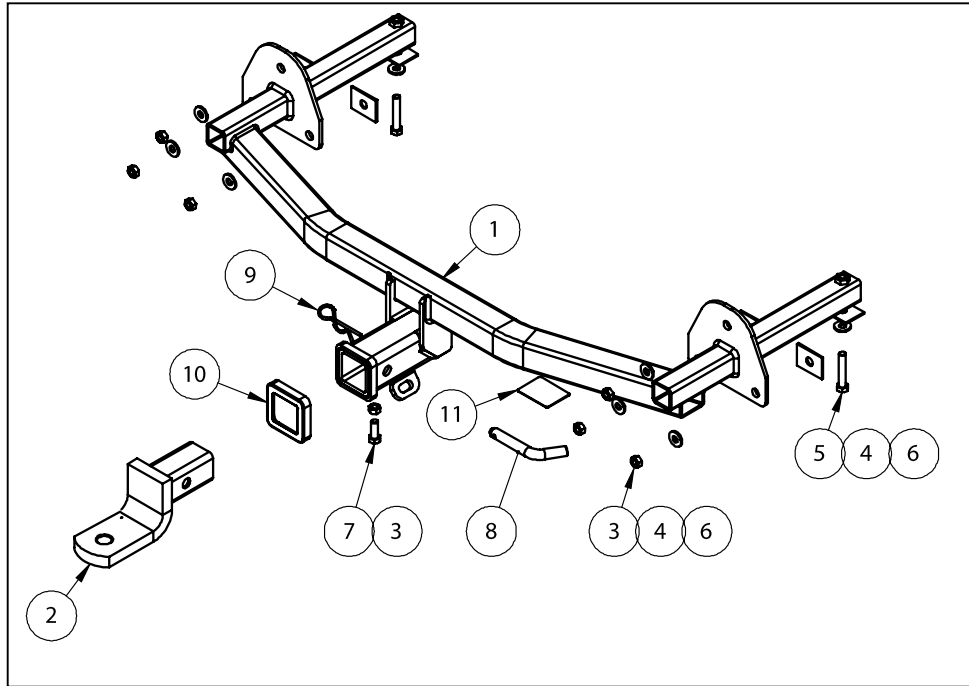

QTY.	DESCRIPTION	ITEM NO.
1	WELDED ASSY	1
1	TBM	2
7	HEX NUT M10x1.5	3
8	WASHER FT M10X25.4X3	4
2	BOLT M10x60x1.5	5
6	FITTING PLATE 53x40x3	6
1	SET SCREW HEX HD M10x30x1.5P	7
1	PULL PIN	8
1	R CLIP	9
1	HITCH BOX COLLAR COVER	10
1	ACRYLIC COMPLIANCE PLATE	11

ADDITIONAL ITEMS

WIRING LOOM FITTING INSTRUCTION LR LABEL

PLUG BRACKET NUT NYLOC



Towbar Fitting Instructions
To Suit **HOLDEN TRAX 2013-ON**
Part Number **QTHD520L**
Rating **1200/120 kg**

PLACE THESE INSTRUCTIONS IN THE VEHICLE'S GLOVEBOX AFTER INSTALLATION IS COMPLETED

INSTRUCTION:

1. Remove 3x Screws from rearwards end of rear wheel well. Repeat for opposite side of vehicle
2. Peel away most of wheel well outer Plastic trim, manipulating small tab flange from slot hole.

ENSURE CAUTION:

Tabs securing trim are brittle and prone to breaking off
Repeat for opposite side of vehicle

3. Unscrew newly exposed Torx Screw securing Bumper Trim to main Chassis.
Repeat for opposite side of vehicle.
4. Remove 2x Screws securing rear tail light from rear of vehicle. These are exposed by removing the tabs covering screws.

Remove tail light from vehicle by pulling rearwards.

Disconnect tail light bulbs from tail light housing, place housing in safe place to side.

5. Remove Screws from lower Bumper trim, located behind rear tyre.
6. Disconnect 4x Scrivets from lower Bumper trim.
7. Carefully peel away Bumper trim from main vehicle chassis.

Place Bumper trim to side in a safe place.

Remove rear impact beam by removing 6x Nuts securing Impact Beam to Chassis. Also remove and retain plastic tabs securing chassis rail to Bumper trim.

Discard beam after removal

8. Place 4x Washer plates on lower studs on rear panel of vehicle.
9. Offer Towbar to vehicle, ensuring Towbar side arms move inside chassis rails and face plates mount to chassis surface.
10. Loosely secure Towbar to vehicle by firstly securing vertical Bolt and Washers to Towbar sidearms. Use supplied Washer Plates to ensure adequate contact area.
11. Secure loosely face mounts of Towbar to vehicle using Nuts provided.

Tighten all Nuts and Bolts to recommended torques.

12. Reattach plastic tabs to vehicle chassis.
13. From the centre of the Bumper trim, make a Bumper Cut. Start cut from upper lip of indentation and cut 90mm Wide and 120mm down (Refer to Figure 1).

Reassemble Bumper following steps 1 – 7 in reverse.

TRAILBOSS

Towbar Fitting Instructions
To Suit **HOLDEN TRAX 2013-ON**
Part Number **QTHD520L**
Rating **1200/120 kg**

PLACE THESE INSTRUCTIONS IN THE VEHICLE'S GLOVEBOX AFTER INSTALLATION IS COMPLETED

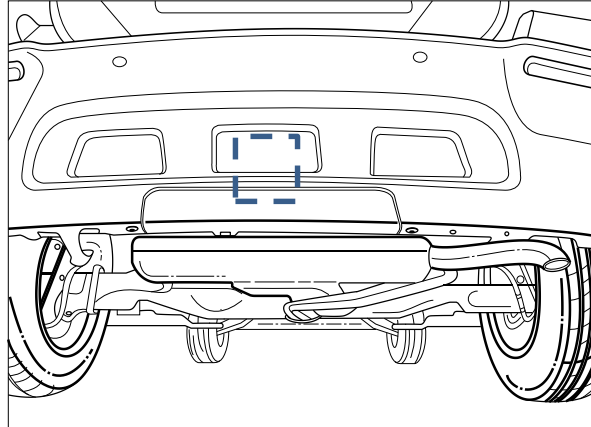

Figure 1



Wiring Loom Fitting Instructions
To Suit Holden Trax
Part Number 101003-WL

Wiring Loom Installation Instructions

Holden Trax
Part No: 101003-WL

Tail Harness Length Required: 1200mm

ECU: 04829 (required only if load is more than 10A)

Wiring Loom Installation Time: Approx 30 Mins



Refer to Page 2 regarding maximum trailer electrical load.



Wiring Loom Fitting Instructions
To Suit Holden Trax
Part Number 101003-WL

Maximum Trailer Electrical Load

The Holden Trax – like many other vehicles – has a limited amount of current available for powering trailer lighting circuits. If the vehicle circuits are overloaded by the trailer lighting circuits, vehicle fuses can fail and potential damage to wiring can occur. While most trailers have a small number of lamps on them, some larger trailers (especially 2 axle trailers and caravans) have a large number of lighting circuits.

The optional power harness and ECU for the Holden Trax allows any large trailer to be towed without concern about drawing too much power from the vehicle circuits. Refer to the tables below to see the maximum lighting loads with and without the ECU and power harness option.

Recommended Maximum Trailer Electrical Load without ECU

Light Signal Name	Load (Watts) total	Current Load (Amps) total (at 12V)
Left Turn	52W	4.3A
Right Turn	52W	4.3A
Tail Lamps	96W	8A
Reverse Lamps	52W	4.3A
Stop Lamps	52W	4.3A

Recommended Maximum Trailer Electrical Load with ECU

Light Signal Name	Load (Watts) total	Load (Amps) total (at 12V)
Left Turn	96W	8 A
Right Turn	96W	8 A
Tail Lamps	132W	11 A
Reverse Lamps	96W	8 A
Stop Lamps	96W	8 A

Wiring Loom Fitting Instructions To Suit Holden Trax Part Number 101003-WL

1. Open the boot and remove the luggage compartment parcel shelf and the luggage compartment rear trim by removing its two fasteners.
2. Remove the luggage compartment foam tool trays by removing its star head fasteners.
3. Remove the clip and the fastener from the RHS luggage compartment trim. Repeat for the LHS trim (LHS trim also requires disconnection of the 2-way connector). Dislodge both LHS and RHS trims.
4. If ECU required, remove the patch connector and go to Step 5. If not, tie back patch connector branch onto main harness and go to Step 6.
5. At the LHS rear quarter area of the vehicle, connect the trailer patch (P/No: 101003-WL) ECU connector (1) to the ECU (P/No: 04829) (2) and mount the ECU into position ensuring the ECU connector is pointing downwards.
6. Secure the trailer patch ground ring (2) to the vehicle grounding point (3).
7. Route the trailer patch harness wire terminals to the vehicle tail light harness wires (4) and scotch lock the terminals (5) by following the table below:

Function	Trailer Patch	Vehicle Connector
L.IND	YELLOW / BLACK	BLUE / WHITE
REVERSE	BLACK / WHITE	GREEN / WHITE
TAIL	BROWN / BLACK	GREY / BROWN
BRAKES	RED / BLACK	GREY / YELLOW

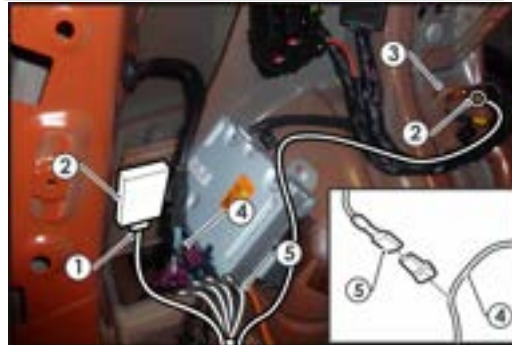

8. **Note: If ECU is not used, go to Step 11. Otherwise, continue:** Route the trailer patch power wire branch (1) to the fuse panel (2). Insert the supplied fuse (3) into the add-a-fuse harness (4). Connect the trailer patch power wire connector (1) to the add-a-fuse harness (4). Insert the add-a-fuse (4) into any of the vacant fuse slots highlighted (5).



Wiring Loom Fitting Instructions To Suit Holden Trax Part Number 101003-WL

9. Route the trailer patch GREEN/BLACK wire (1) across to the RHS tail light harness (2). Scotch lock the terminal (1) onto the vehicle harness wire (2) by following the table below:

Function	Trailer Patch	Vehicle Connector
R.IND	GREEN / BLACK	BLUE / PURPLE

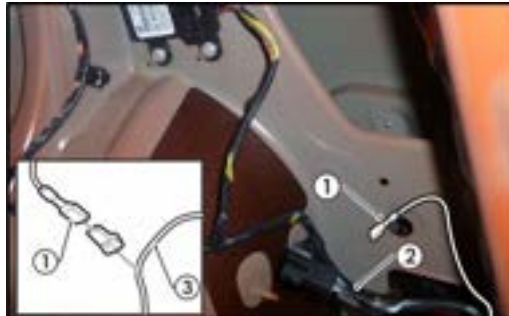

10. At the rear of the luggage compartment, remove the existing grommet from the grommet hole and then from the outside, route the tail harness (tail length: 1200mm) into the vehicle grommet so that it is seated correctly. Connect the trailer patch connector to the tail harness connector. **Note: If the grommet hole is unavailable, drill a 30mm hole in a suitable location nearby and then spray on rust inhibitor on the drilled out hole.**
11. At the exterior rear of the vehicle, route the tail harness across the towbar and mount the tail harness socket to the towbar mounting plate using the supplied M4 fasteners.
12. Test the trailer wiring harness function using a light board or multimeter.
13. Secure all harnesses using cable ties (not supplied).
14. Re-fit all removed parts and secure all fasteners, ensuring there are no squeaks or rattles.
15. Place the fitting instructions in the glove box after fitment.



FITTING INSTRUCTIONS

Silent Anti-Rattle Hitch Pin (PR0001)

• These fitting instructions are supplied to ensure understanding of how the HITCH PIN should be fitted and used correctly.

• Once installed, we recommend **ALL** instructions are kept and placed in the vehicle glove box.

NOTE: Routine maintenance and inspection of the towbar & HITCH PIN is required. Regularly inspect for wear and check the tightness of the Hitch Pin. Follow instructions below to retighten the nut when necessary.

***Do not tow with your vehicle if the R CLIP or the HITCH PIN is loose or missing. Replacement parts are available from your Pro Series Distributor.**

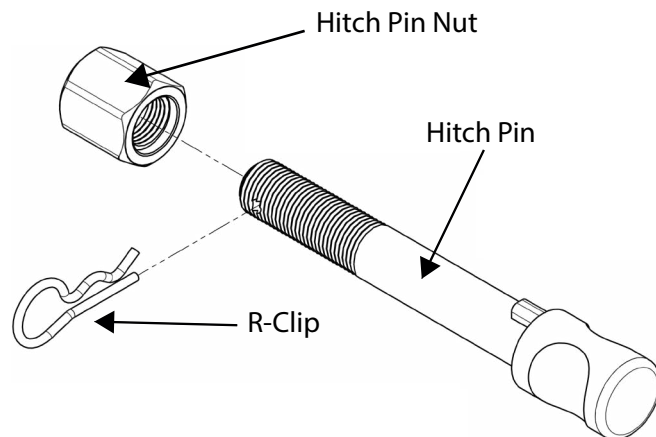

Fig 1. Silent Anti-Rattle Hitch Pin assembly

STEP 1

Insert Trailer Ball Mount (TBM) into towbar HITCHBOX, aligning hole in TBM SHANK with hole in HITCHBOX (Fig 2).

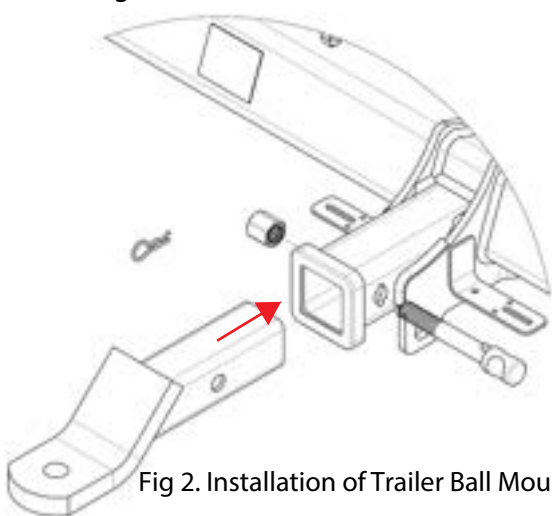

Fig 2. Installation of Trailer Ball Mount

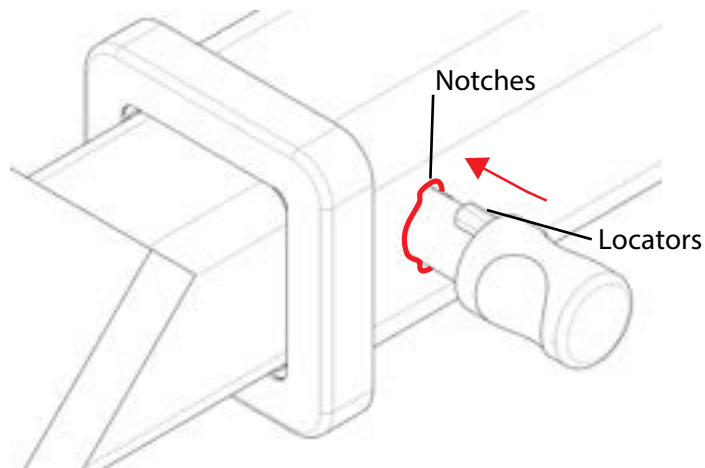

Fig 3. Silent Anti-Rattle Hitch Pin orientation

STEP 2

Insert HITCH PIN through hole in HITCHBOX and hole in TBM SHANK; ensure the LOCATORS are inserted into the NOTCHES in the HITCHBOX (Fig. 3).

STEP 3

Screw HITCH PIN NUT onto HITCH PIN; tighten HITCH PIN NUT until finger tight, ensuring TBM is restrained from movement.

STEP 4

Tighten HITCH PIN NUT by turning nut a further 1/8th of a turn in the clockwise direction using a 24mm spanner (Fig. 4).

STEP 5

Install HITCH PIN R CLIP through the hole on the HITCH PIN (Fig. 1).

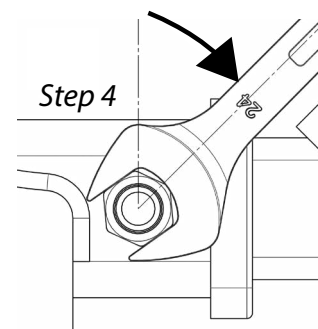

Fig 4. Tightening of Silent Anti-Rattle Hitch Pin Nut