



Towbar Fitting Instructions
To Suit **HOLDEN ACADIA AC CL4 TBM KIT**
Part Number **QTHD777**
Rating **2000 / 200 kg**

PLACE THESE INSTRUCTIONS IN THE VEHICLE'S GLOVEBOX AFTER INSTALLATION IS COMPLETED

WARNING:

1. Do not, drill, cut, weld or otherwise modify the tow bar.
2. If you are using electric welding on a motor vehicle, **always** check that the vehicle is not equipped with electronic engine or instrument management equipment. Failure to do so could **destroy** any onboard computers. If in doubt, check with the vehicle's manufacturer.
3. The high tensile fasteners supplied with this product were used to achieve the specified rating. If replacement is required ensure that fasteners of the same rating & quality are used. Contact an authorised **Trailboss** dealer if further information is required.
4. If TBM is used in inverted position tow ball may make contact with rear tailgate when lowered, which could cause damage.

General:

1. Ensure all hardware items have been included refer to assembly diagram.
2. It is recommended that the instructions are read through and completely understood before making any attempt to fit this product.
3. Be wary of any changes to vehicle designs or other accessories that may conflict with the installation of this product.
4. Before drilling ensure that the area is clear of fuel, electrical & other components.
5. All holes drilled into the body panels shall have all burrs & swarf removed then coated with a suitable rust preventative paint.
6. For vehicles that require the bumper to be cut. Ensure cut out area is in correct position on the vehicle prior to cutting the bumper.
7. The high tensile fasteners supplied with this product were used to achieve the specified rating. If replacement is required ensure that fasteners of the same rating & quality are used. Contact an authorized **Trailboss** dealer if further information is required.
8. Ensure that all hardware is fastened to torque list below check fasteners on regular basis.
9. Tow bar load rating sticker provided with this product shall be conspicuously located on inside rear end of the driver's door. **(See diagram below).**
10. Trailboss recommends that you check your tow ball to ensure that it complies with the Australian standards **AS 4177.2**.
11. **PLEASE NOTE:** It is advised to remove your LUG or TBM when not actually towing so as to produce a clear view of the vehicles registration plate if obscured, and to also provide maximum available departure angle

FOR TRAILER TOWING PURPOSES ONLY
For towing capacity details please refer to vehicle
owner's manual or to the manufacturer. Overloading
can void your warranties.

Tow bar Maintenance and Care.

Trailboss recommends that bolt torque's, as listed below, are routinely and regularly inspected and checked for correct tension. Replace any worn or defective parts.

We recommended to remove Tow Ball Mounts (TBM's, tongues or lugs) when not being used for any considerable length of time. So as to avoid injury, when not towing it is suggested that the tongue, Pull Pin and R-clip are removed then stored in a safe, clean and dry place, away from excessive moisture.

Hitch Pull Pins and spring "R" clips are regularly checked for proper installation. Replace any worn or defective parts.

Cequent Customer Service
Ph: 1800 812 017 Fax: 03 9898 3299
Email: info@cequent.com.au
Post: PO Box 4050, Dandenong South VIC 3175



Towbar Fitting Instructions
To Suit **HOLDEN ACADIA AC CL4 TBM KIT**
Part Number **QTHD777**
Rating **2000 / 200 kg**

PLACE THESE INSTRUCTIONS IN THE VEHICLE'S GLOVEBOX AFTER INSTALLATION IS COMPLETED

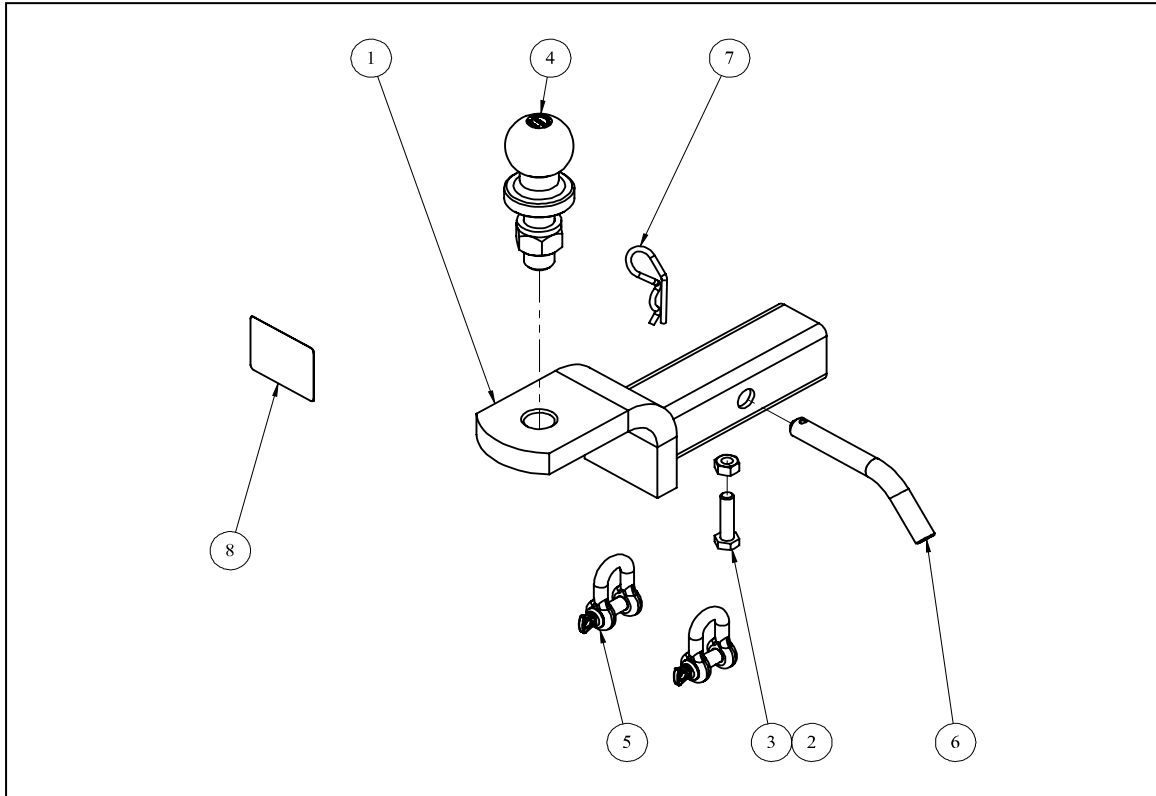

ITEM	DESCRIPTION	QTY
1	TRAILER BALL MOUNT	1
2	HEX NUT M10x1.5	1
3	BOLT M10 - 1.5 x 45mm GR 10.9	1
4	TOWBALL 50mm	1
5	"D" SHACKLE 10mm	2
6	PIN PULL CL4 NO COLLAR ZNPLT PIN04	1
7	R-CLIP SM BENT SILVER MR12 PIN02	1
8	ACRYLIC COMPLIANCE LABEL	1

Cequent Customer Service
Ph: 1800 812 017 Fax: 03 9898 3299
Email: info@cequent.com.au
Post: PO Box 4050, Dandenong South VIC 3175

Towbar Fitting Instructions
To Suit **HOLDEN ACADIA AC CL4 TBM KIT**
Part Number **QTHD777**
Rating **2000 / 200 kg**

PLACE THESE INSTRUCTIONS IN THE VEHICLE'S GLOVEBOX AFTER INSTALLATION IS COMPLETED

1. To expose towbar hitch receiver, unclip rear bumper fascia by half-turning 2 x clips located near bottom edge of bumper.

Gently remove fascia and store in vehicle.
Fascia can be reinstalled when not towing.



2. Fit TBM assembly to the towbar hitch receiver in the upright-position and secure with Pull Pin. Ensure to fit the R-Clip to the Pull Pin.
3. Fit the D-Shackles to the chain connection lugs.
4. Install anti-rattle bolt and nut.



5. Affix the TBM kit compliance label onto the towbar.
6. Place load rating sticker inside driver's door next to existing towbar load rating label.

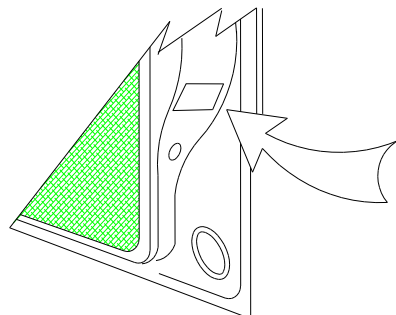

Cequent Customer Service
Ph: 1800 812 017 Fax: 03 9898 3299
Email: info@cequent.com.au
Post: PO Box 4050, Dandenong South VIC 3175