

PRODUCT DETAILS:

Part Number:	QTHV05L	Maximum Towing Braked:	1500	kg
ECU Number:	04826	Maximum Towing Unbraked:	750	kg
Tail Harness Length Required:	1800 mm	Maximum Static Ball Load:	150	kg
TBM/Lug Part Number:	21232			

FITTING DETAILS:

Towbar Installation Time:	60 Mins.	RPA Disable/Other:	NO
Total Installation Time:	120 Mins.		
Bumper Cut Required:	Yes		

Note:

- Rear Cross traffic is disabled via accessing Intelligent systems menu on the centre infotainment.
- RPA is disable via button on dash.
- 13mm drill required.

TRAILBOSS RECOMMENDS THAT INSTRUCTIONS ARE READ AND UNDERSTOOD COMPLETELY PRIOR TO FITMENT.

BEFORE YOU START:

Check all hardware items have been included refer to assembly diagram.
Please ensure this towbar is only fitted to vehicle models as per Trailboss application guide.

Bumper Cuts

Vehicle and bumper variations can and do occur during vehicle manufacture after initial towbar design. Fitment of towbar to vehicle and accuracy of bumper cut must be assessed prior to any bumper modifications made. Incorrect bumper cuts are not covered under Trailboss warranty.

NOTE: Bumper cuts need to be approached with care, refer to notes below.

- Bumper centreline – where the centreline of the bumper needs to be determined, the installer must assess centre point by measurement of bumper width or determining two symmetrical reference points to give centreline.
- Bumper edge – To assist with accurate bumper cut measurement, reference to the start of the bumper edge is now being commonly used.
 - Measure from bottom edge along bumper and around corner to the 70 mm point (Figure 1).
 - Do not measure from visible bumper front of corner, upwards (Figure 2).

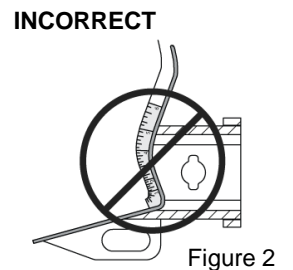
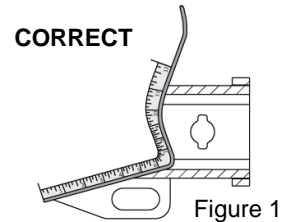

Drilling

- For any required drilling during installation, ensure that the area is clear of fuel, electrical & other components that may be damaged.
- All holes drilled into metal body panels shall have all burrs & swarf removed then coated with a suitable rust preventative paint.

Bolts/Fasteners

- Ensure that all hardware is fastened to correct torque as specified in this fitting instruction.
- All fasteners supplied with this product are used to achieve a specified clamp loading. If replacement is required ensure that fasteners of the same grade and class are used.

NOTE: Achieving correct torque is critical to proper installation and responsibility of the installer. Towbar failures attributed to tension issues from over tightening or under tightening are not covered by Trailboss warranty.

Product Labels

- a. Towbar load rating sticker provided with this product shall be conspicuously located on inside rear end of the driver's door.

WARNING:

Do not, drill, cut, weld or otherwise modify the towbar.

FOR TOWING PURPOSES ONLY - This towbar is designed and tested by Trailboss to adhere to ADR 62/02 which provides only for the expected load demands of towing.

i TOWBAR ASSEMBLY DIAGRAM

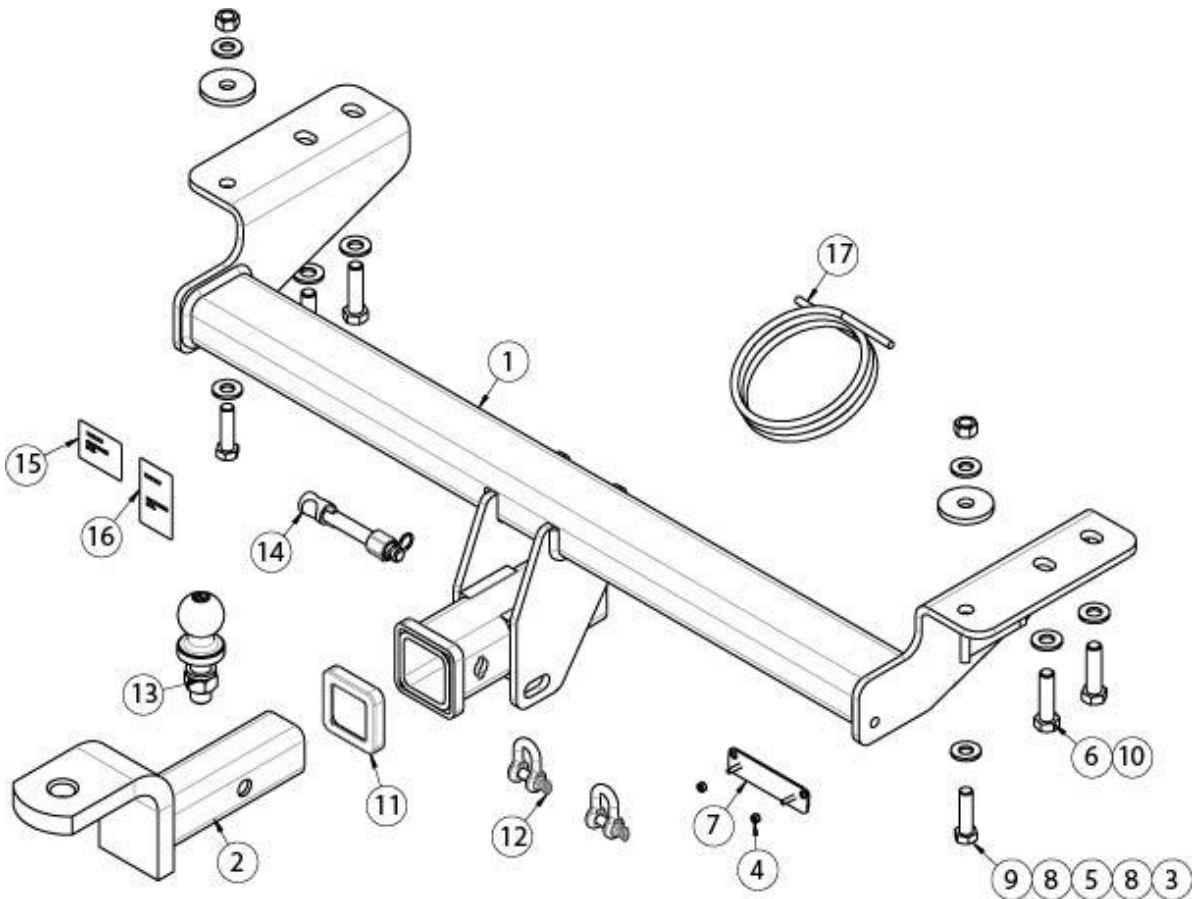

ITEM	DESCRIPTION	QTY
1	HAVAL JOLION WELDED ASSEMBLY	1
2	TRAILER BALL MOUNT	1
3	NUT HEX HD M12x1.75P	2
4	NUT NYLOC HEX HD M4x0.7P	2
5	FITTING PLATE Ø50mm	2
6	BOLT HEX HD M14x50x1.5P	4
7	PLUG BRACKET	1
8	WASHER PLAIN M12x27x3.0	4
9	BOLT HEX HD M12x45x1.75P	2

ITEM	DESCRIPTION	QTY
10	WASHER PLAIN M14x28x3	4
11	HITCH BOX COLLAR COVER	1
12	"D" SHACKLE 10mm	2
13	TOWBALL 50mm	1
14	SMART PIN SILVER	1
15	COMPLIANCE LABEL	1
16	LOAD RATING LABEL	1
17	WIRING LOOM	1

1. Open tailgate, lift the plastic screw covers and remove the 2 x screws securing the taillight along with the 2 x screws on the rubber boot stops.

Remove taillight (pull rearwards) and disconnect electrical connections.

2. Remove 1 x torx from the bumper.

Repeat steps 1 and 2 for other side.

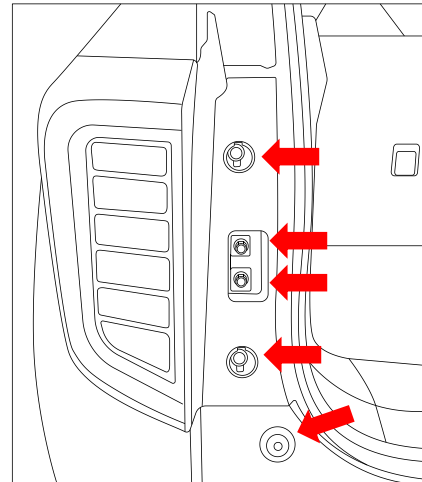

3. In wheel arch, remove 3 x screws.

Repeat for other side.

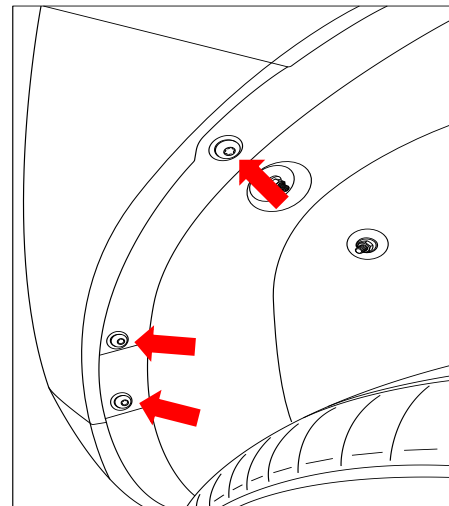

4. From under the vehicle, remove 1 x scrivet from the bumper.

Repeat for other side.

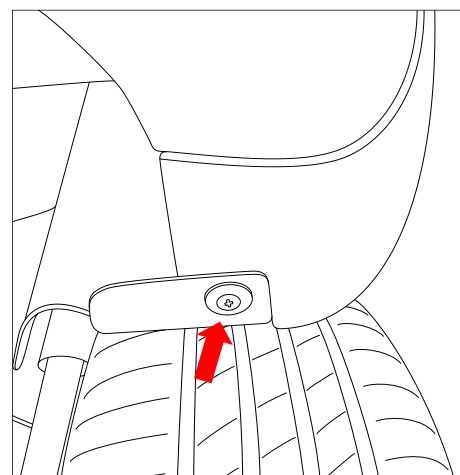

5. Along the underside of the bumper, remove 2 x screws.

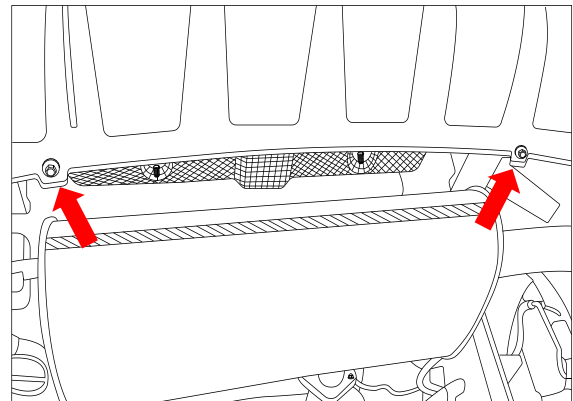

6. Peel away from the sides and remove bumper. Ensure to disconnect any wiring connectors from the main loom located on the LH side.

Place the bumper assembly on a bumper stand in a safe place.

7. Remove impact beam from vehicle secured with 8 nuts on studs (4 per side). Retain impact beam and nuts for re-fitment.

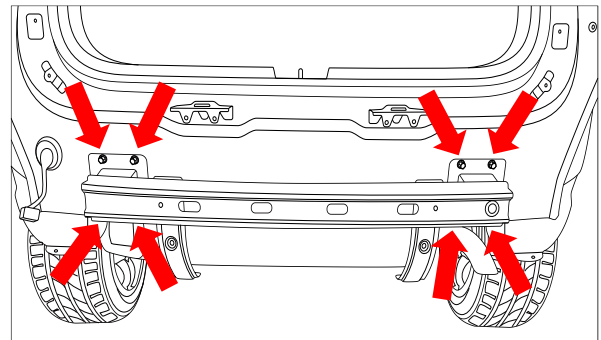

8. Enlarge the rear chassis rail mounting hole to accommodate a M12 bolt (Drill hole to 13mm). Deburr and apply an anti-corrosive coating to the exposed area.

Repeat for other side.

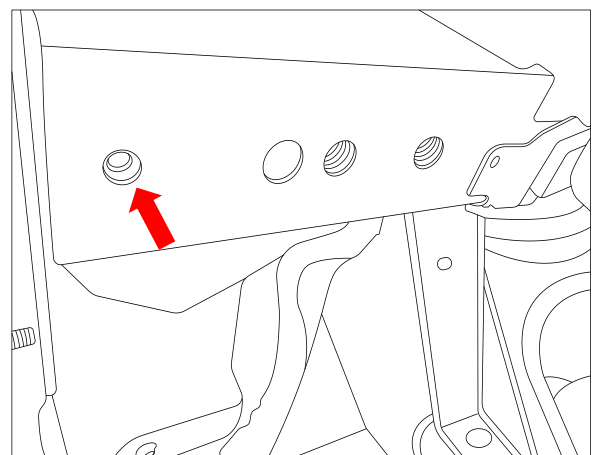

9. Position the towbar up to the chassis rail and loosely secure with 2 x M14 bolts complete with 1 x washer per bolt.

Repeat for the other side.

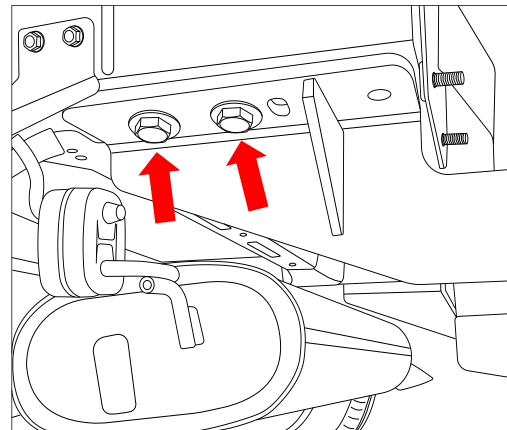

10. Secure the (drilled out) rear most hole position with 1 x M12 bolt complete with 1 x fitting plate, 2 x washers and 1 x nut. Ensure that the fitting plate is on the inside of the chassis rail.

Repeat for the other side.

Tighten all fasteners to the following torque.

M12 x 1.75 Gr 8.8 : 77Nm

M14 x 1.5 Gr 8.8 : 140Nm

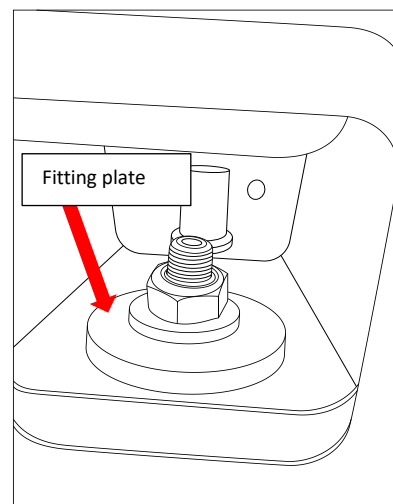

11. For bumper cut determine the centre of the bumper, measure, mark off and cut out a section 90 mm wide and 100mm long measured from the bottom edge of the bumper as depicted in the image. For a clean fit, you may have to notch out a small section on the raised section as required.

Ensure to not damage wiring in the bumper.

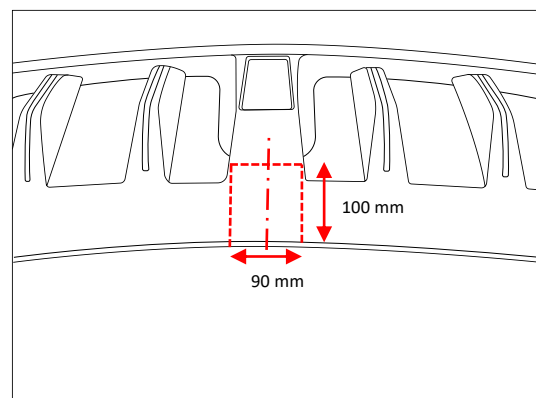

12. At an appropriate position on the bumper, mark out and drill 2x $\varnothing 5\text{mm}$ holes 69mm apart on bumper skin to support plug bracket.

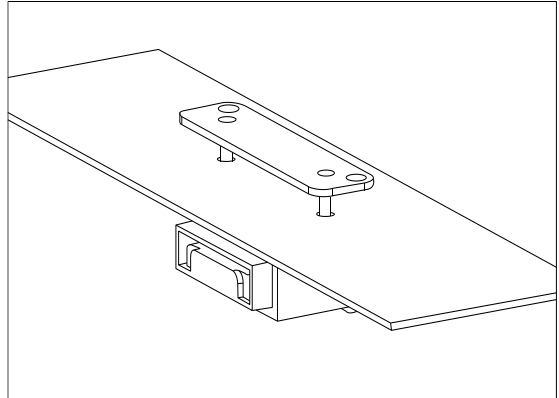

13. Fold down rear passenger seats (1).
14. Remove Luggage compartment floor and vehicle tool storage to expose Battery (2). Disconnect the vehicle battery negative terminal (3).

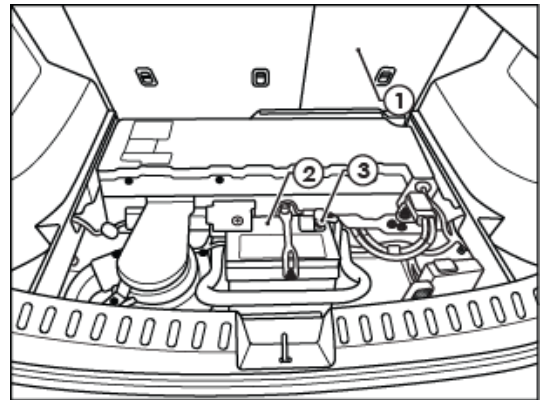

15. At the rear of the vehicle, remove the two caps (1) and bolts (2) securing the Tail Lamps.
16. Dislodge the tail lamps and disconnect the Connectors before removing both Tail Lamp Assemblies
17. Remove Rear Scruff plate (3) by unclipping the two push clips.

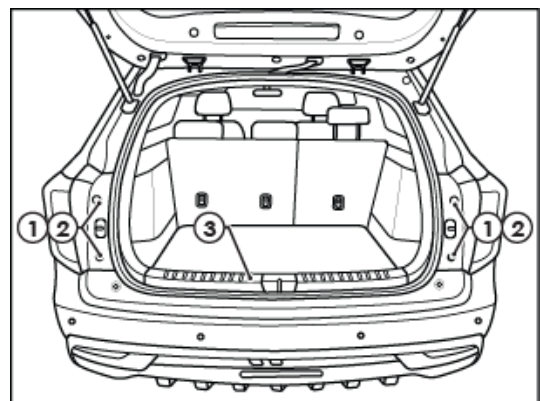

18. Remove screws and bolts holding both the RHS & LHS Rear Interior Trim (1).
19. Dislodge both the RHS & LHS Rear Interior Trim (1) towards the centre of the vehicle.

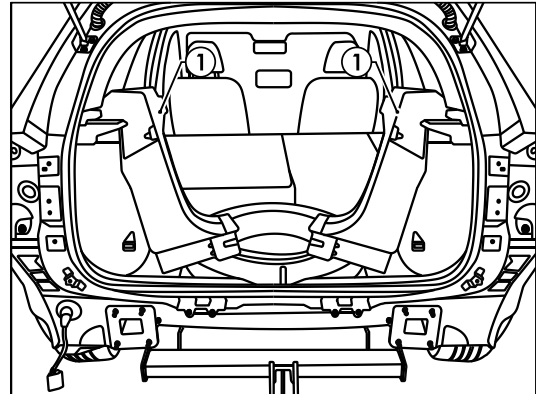

Trailer Harness LHS Pin Assignment.

20. House the 4 terminals (1) into the LHS Male/Female Taillight Connector (2) on the harness according to the table and images below.
21. Engage the secondary lock.

Cavity Number	Function	Trailer Patch
1	Stop	Red/Black
2	Tail	Brown/Black
3	LHS Indicator	Yellow/Black
4	Pass Thru	Grey
5	-	Grey

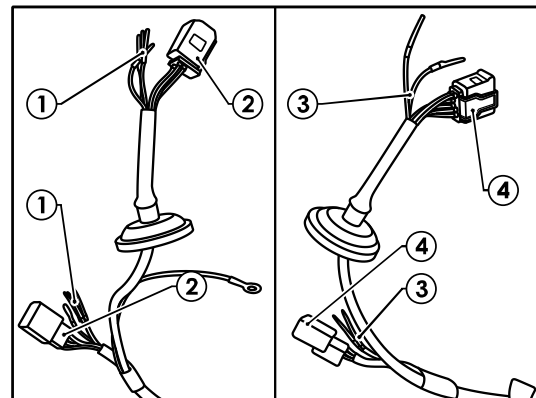

Trailer Harness RHS Pin Assignment.

22. House the 2 terminals (3) into the RHS tail light connector (4) on the harness according to the table below.
23. House the secondary lock.

Cavity Number	Function	Trailer Patch
1	-	Grey
2	-	Grey
3	RHS Indicator	Green/Black
4	Pass Thru	Grey
5	-	Grey

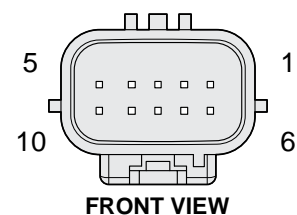
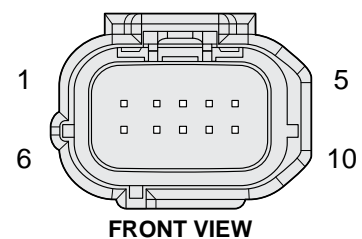

24. Push the Vehicle LHS tail lamp grommet (1) and connector inside the vehicle and connect the vehicle LH tail lamp connector to the mating Trailer Harness connector.
25. Pull the Trailer Wiring Harness LHS tail lamp connector back thru the hole and secure the grommet.
26. Route the Trailer Wiring Harness across to the RHS Tail Lamp and repeat the above process, ensuring to tuck the harness as you go.

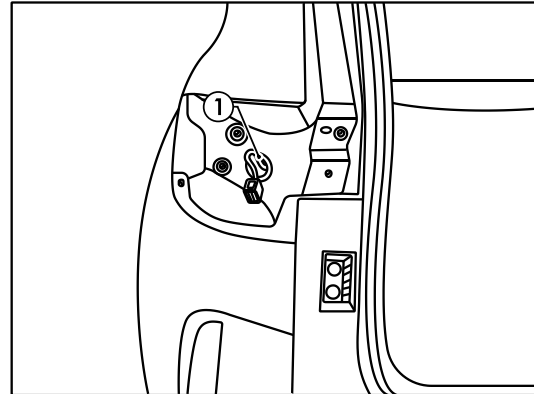

27. Behind the LHS rear panel, clean ECU mounting location (1) shown and base of ECU (2) using supplied cleaning pad.
28. Connect the Trailer Harness 12-way connector (3) to ECU (2) and mount in the location shown using Double Sided Tape
29. Secure Trailer Harness (4) to existing vehicle harness using supplied 200mm cable ties.

Note: Mount the ECU, ensuring the connectors is orientated downwards.

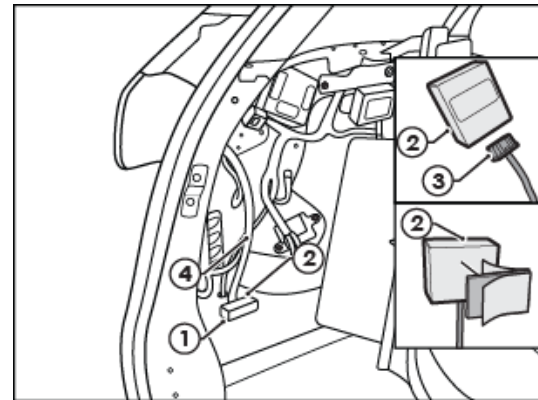

30. In the rear cabin area, connect the white M6 ground wire ring terminal to the vehicle earthing point (1) on the rear arch.

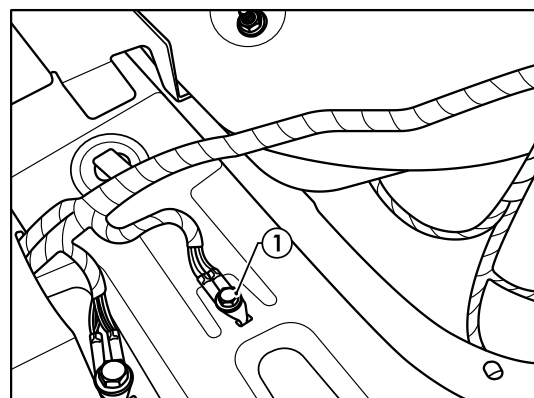

31. Route the orange power wire towards the RHS vehicle interior Fuse box.
32. Tuck the power wire under the trim as required.
33. Remove Fuse box Cover to expose 6mm positive stud (1). Connect the M6 positive ring terminal to the positive stud (1) on the fuse box.

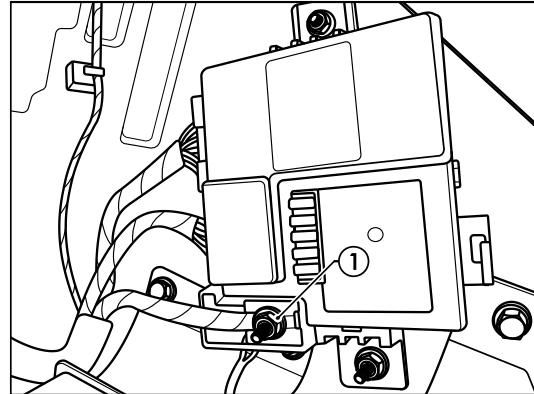

34. On the LHS of the vehicle remove the existing grommet (1) and drill out the hole to 30mm.

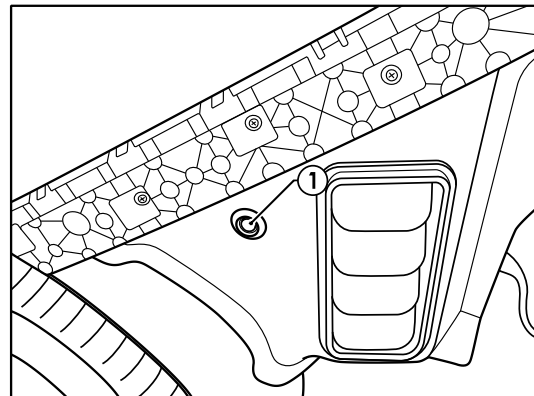

35. Secure tail harness to towbar.
36. Route tail harness up through chassis and previously drilled 30mm hole.
37. Seat grommet in 30mm hole and route to trailer harness blue connector on patch loom.

Note: Keep harness routing clear of all sharp edges, moving parts and places of extreme heat.

Note: Ensure grommet is seated correctly and makes a good seal.

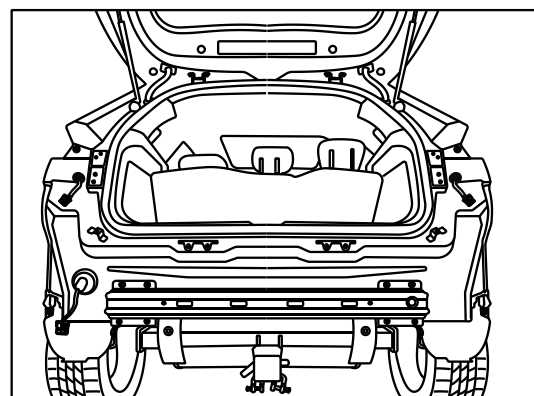

38. For RPA Disable locate the bumper connector on the LHS rear of the vehicle.

Note: RPA Disable Grey & Grey/Black Wires may need to be extended.

39. Peel back the tube on Pin 5 Black/Yellow wire, on the 20 Way Connector and cut it 100mm back from the connector. Strip, crimp, and seal the tail harness (04935) GREY and GREY/BLACK wires to the vehicle Pin 5 Yellow/Black wire (1). (1 wire going to each side Of the Black/Yellow wire).

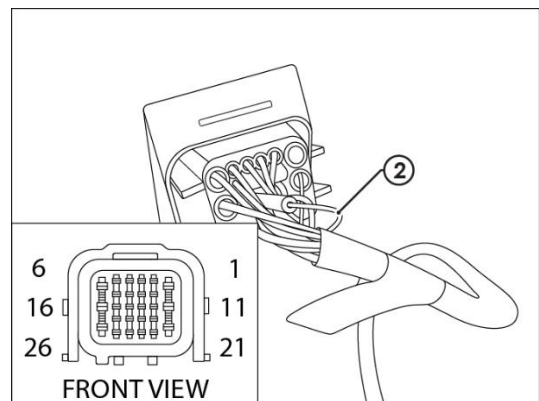
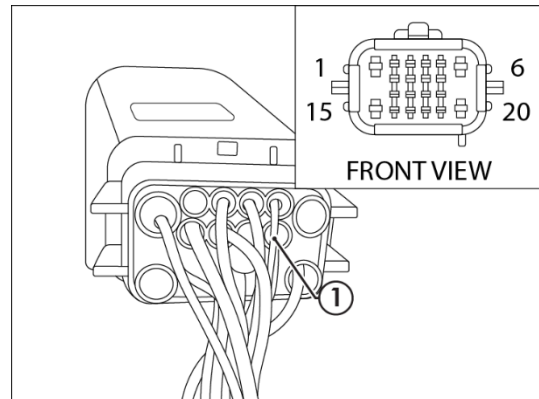

40. Connect the tail harness (tail length 1800mm) 8-way connector to the trailer patch mating 8-way connector.

41. Use silicone grease to seal the blue connectors.

42. Secure all harness using supplied cable ties.

43. Reconnect the vehicle battery negative terminal.

44. Refit all removed parts and secure all fasteners, ensuring there no squeaks or rattles.

45. Test the trailer patch function using a light board or multi-meter.

Place the fitting instructions in the glove box after fitment.



CUSTOMER INFORMATION

PLACE THESE INSTRUCTIONS IN THE VEHICLE'S GLOVEBOX AFTER INSTALLATION

THANK YOU FOR PURCHASING TRAILBOSS. WITH CORRECT MAINTENANCE AND CARE THIS PRODUCT WILL PROVIDE A LIFETIME OF TROUBLE-FREE OPERATION.

TOWBAR MAINTENANCE AND CARE:

1. Trailboss recommend that the towbar LUG or TBM (Trailer Ball Mount) Pull Pin and R-clip are removed and stored when not in use. Removal of LUG or TBM (Trailer Ball Mount) is advisable when not in use to assist with any of the following.
 - Ensure rear number plate is not obscured.
 - Allow maximum available departure angle and prevent any potential interference.
 - Prevent possible interference with vehicles reverse sensors or camera detecting a tow ball mount as an obstruction during reversing.
 - Removes towball mount as an obstruction for when moving around the rear of the vehicle.
2. Trailboss recommends routine inspection of your towbar to ensure trouble free towing.
 - Bolt security and tension should be regularly inspected and checked for correct tension. Replace any worn or defective parts with suitable grade & class fasteners. Inspection should be requested to coincide with vehicle major services.
3. It is the owner's responsibility to ensure towing and down ball weight capacities of the towing vehicle are not exceeded.
 - Towing and down ball weights allowable may differ according to model variations. Please refer to owner's manual or vehicle dealer to confirm exact rating for your vehicle model variant.
 - It is not uncommon for the vehicle tow rating to differ from the towbar rating. When this occurs, the lesser rating must be adhered to.
 - For vehicles fitted with enhanced vehicle functions that may be altered/changed when towing i.e Trailer sway mitigation, blind spot detection, adaptive cruise control etc. Please consult owner's manual to understand changes enabled when towing and after towing.

WARRANTY INFORMATION:

Trailboss Towbars are covered by a Lifetime Warranty.

Our goods come with guarantees that cannot be excluded under the Australian Consumer Law. You are entitled to a replacement or refund for a major failure and for compensation for any other reasonably foreseeable loss or damage. You are also entitled to have the goods repaired or replaced if the goods fail to be of acceptable quality and the failure does not amount to a major failure.

For further details please contact customer service on 1800 812 017.

PRO SERIES SILENT ANTI-RATTLE HITCH PIN

Your Trailboss towbar is equipped with a Pro Series Silent Anti-Rattle Hitch Pin technology to help reduce towbar tongue rattle in most driving conditions. Please ensure below instructions are understood and routine maintenance is carried out to ensure best towing experience.

Regularly inspect for wear and check the tightness of the Silent Anti-Rattle Hitch Pin. Follow instructions below to re-tighten the nut as necessary when movement and noise in the tow ball mount is noted.

- Before towing, ensure R-Clip is properly installed and hitch pin nut is installed and tensioned. Replacement parts are available from your Pro Series Distributor.

TOWBALL MOUNT REMOVAL/INSTALLATION

STEP 1

Insert Trailer Ball Mount (TBM) (a) into towbar hitchbox (b), aligning hole in TBM shank (c) with hole in hitchbox (d) (Fig. 1)

STEP 2

Insert Silent Anti-Rattle Hitch Pin (e) through hole in hitchbox and hole in TBM shank (g); ensure the locators are inserted into the notches in the hitchbox (Fig. 2)

STEP 3

Screw Silent Anti-Rattle Hitch Pin Nut (f) onto Smart Pin (g); tighten Smart Pin Nut until finger tight, ensuring TBM is restrained from up and down movement.

STEP 4

Tighten Silent Anti-Rattle Hitch Pin Nut by turning nut a further 1/8th of a turn in the clockwise direction using a 24mm spanner (Fig. 4).

STEP 5

Install Silent Anti-Rattle Hitch Pin R-Clip through the hole that provides best clearance or easiest access. (Fig. 5)

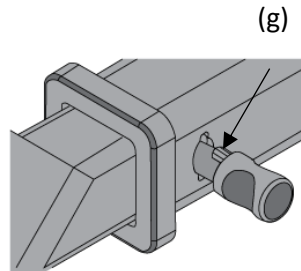
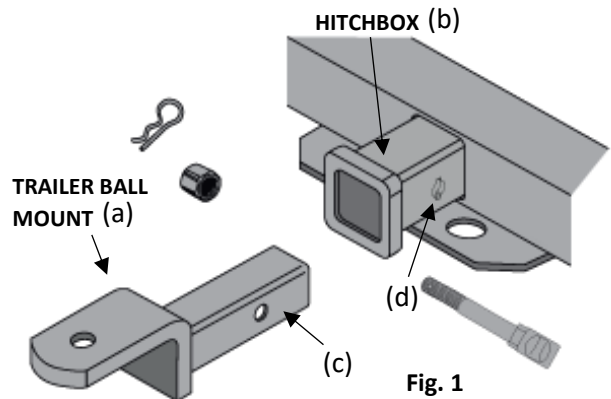

Fig. 2

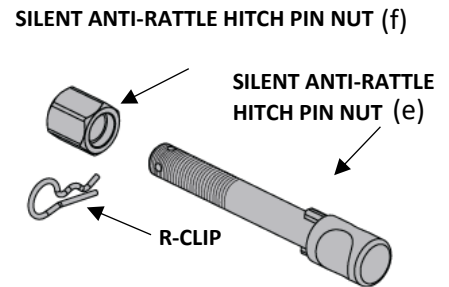

Fig. 3

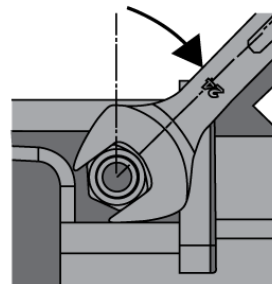

Fig. 4

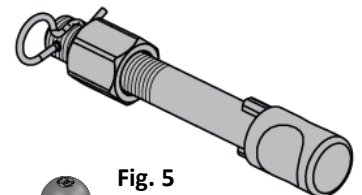

Fig. 5

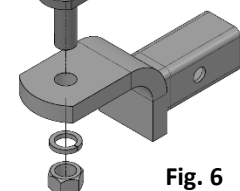

Fig. 6