



# TOWBAR INSTALLATION INSTRUCTIONS

PART NUMBER QTHY270L

HYUNDAI TUCSON TL3 KOREA CL4

## PRODUCT DETAILS:

<b>Part Number:</b>	QTHY270L	<b>Maximum Towing Braked:</b>	1900	kg
<b>ECU Number:</b>	04826	<b>Maximum Towing Unbraked:</b>	750	kg
<b>Tail Harness Length Required:</b>	1200 mm.	<b>Maximum Static Ball Load:</b>	100	kg
<b>TBM/Lug Part Number:</b>	21360			

## FITTING DETAILS:

<b>Towbar Installation Time:</b>	60 Mins	<b>RPA Disable/Other Notes:</b>	NO
<b>Total Installation Time:</b>	110 Mins	* Electric Brake Input Location: Near access grommet * Use Tail 04936 and follow instruction to enable automatic RPA disable when towing	
<b>Bumper Cut Required:</b>	Yes		

### TRAILBOSS RECOMMENDS THAT INSTRUCTIONS ARE READ AND UNDERSTOOD COMPLETELY PRIOR TO FITMENT.

#### BEFORE YOU START:

Check all hardware items have been included refer to assembly diagram.  
Please ensure this towbar is only fitted to vehicle models as per Trailboss application guide.

#### Bumper Cuts

Vehicle and bumper variations can and do occur during vehicle manufacture after initial towbar design. Fitment of towbar to vehicle and accuracy of bumper cut must be assessed prior to any bumper modifications made. Incorrect bumper cuts are not covered under Trailboss warranty.

**NOTE: Bumper cuts need to be approached with care, refer to notes below.**

- Bumper centreline – where the centreline of the bumper needs to be determined, the installer must assess centre point by measurement of bumper width or determining two symmetrical reference points to give centreline.
- Bumper edge – To assist with accurate bumper cut measurement, reference to the start of the bumper edge is now being commonly used.
  - Measure from bottom edge along bumper and around corner to the 70 mm point (Figure 1).
  - Do not measure from visible bumper front of corner, upwards (Figure 2).

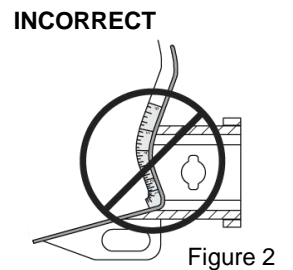
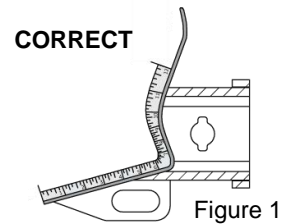

#### Drilling

- For any required drilling during installation, ensure that the area is clear of fuel, electrical & other components that may be damaged.
- All holes drilled into metal body panels shall have all burrs & swarf removed then coated with a suitable rust preventative paint.

#### Bolts/Fasteners

- Ensure that all hardware is fastened to correct torque as specified in this fitting instruction.
- All fasteners supplied with this product are used to achieve a specified clamp loading. If replacement is required ensure that fasteners of the same grade and class are used.

**NOTE: Achieving correct torque is critical to proper installation and responsibility of the installer. Towbar failures attributed to tension issues from over tightening or under tightening are not covered by Trailboss warranty.**

#### Product Labels

- a. Towbar load rating sticker provided with this product shall be conspicuously located on inside rear end of the driver's door.

#### WARNING:

**Do not, drill, cut, weld or otherwise modify the towbar.**

**FOR TOWING PURPOSES ONLY - This towbar is designed and tested by Trailboss to adhere to ADR 62/02 which provides only for the expected load demands of towing.**

PLACE THESE INSTRUCTIONS IN THE  
VEHICLE'S GLOVEBOX AFTER INSTALLATION

### **i** TOWBAR ASSEMBLY DIAGRAM

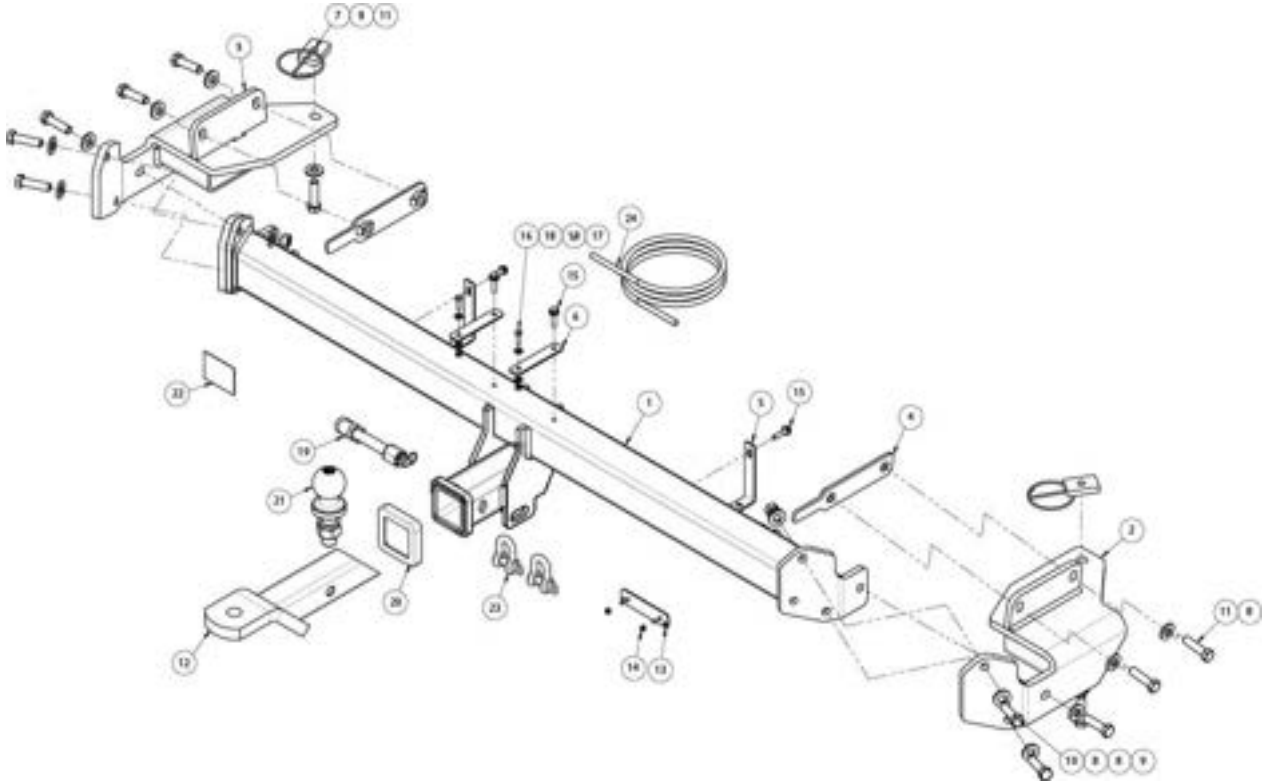

ITEM	DESCRIPTION	QTY
1	KIA SPORTAGE WELDED ASSY	1
2	SIDE ARM ASSY RH	1
3	SIDE ARM ASSY LH	1
4	CHASSIS NUT PLATE ASSY	2
5	BUMPER TAB	2
6	SMART KEY ANTENNA BRACKET	2
7	M12x1.25 TAP PLATE WITH 300 WIRE	2
8	WASHER PLAIN 1/2X1-1/8X16G	18
9	NUT HEX HD M12 X 1.25P G8	6
10	SET SCREW M12 - 1.25 x 45mm GR 8.8	6
11	SET SCREW HEX HD M12 X 45 X 1.25P G10.9	6
12	TOW BALL MOUNT	1

ITEM	DESCRIPTION	QTY
13	VE PLUG BRACKET	1
14	NUT NYLON LOCK HEX HD M4X0.7P G8	2
15	TEK SCREW 14-20 HEX HD 22mm	4
16	SET SCREW HEX HD M5x20x0.8P	2
17	NUT NYLON INS LOCKHEX HD M5X0.8P G8	2
18	WASHER FLAT M6X12.5X1.2	4
19	HITCH BOX COLLAR COVER	1
20	"D" SHACKLE 10mm	2
21	SILENT HITCH PIN – SILVER	1
22	TOWBALL 50mm	1
23	ACRYLIC COMPLIANCE LABEL	1
24	WIRING LOOM	1

1. Remove plastic trim cover adjacent to taillight assembly.

Repeat for opposite side of vehicle.

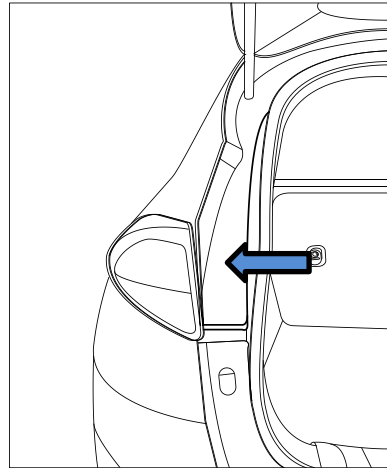

2. Remove 2 x Screws securing taillights to vehicle.  
Remove taillight assembly.

Repeat for opposite side of vehicle.

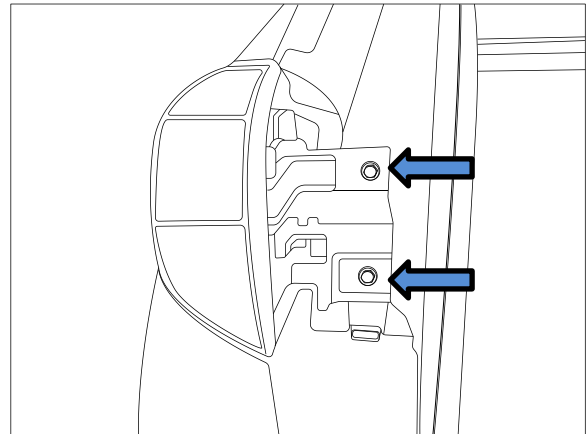

3. Remove 2 x push Rivets from taillight cavity.

Repeat for opposite side of vehicle.

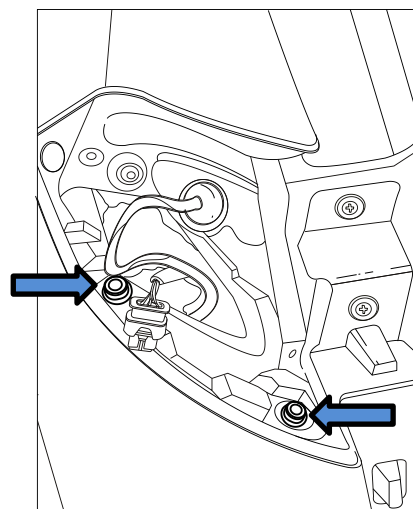

4. Remove 3 x Screws and 1 x bolt within rear wheel arch.

Repeat for opposite side of vehicle.

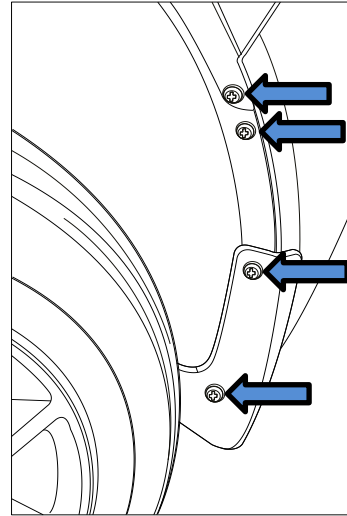

5. Remove 2 x Screws adjacent to chassis rail, securing rear impact beam to rear the panel.

Repeat for opposite side of vehicle.

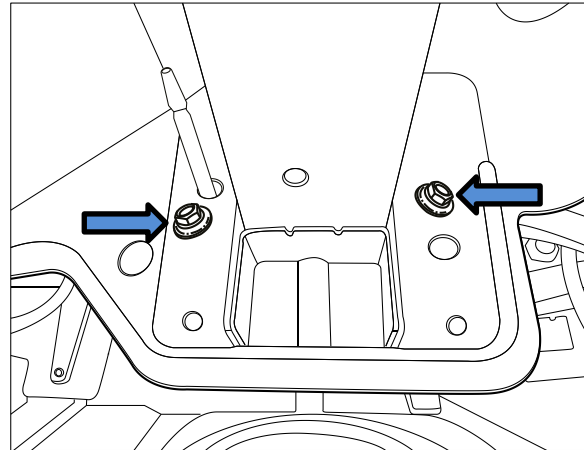

6. Remove 3 x push Rivets under vehicle behind rear wheel arch and 1x push Rivet from within rear wheel arch.

Repeat for opposite side of vehicle.

7. Remove plastic undertray from behind rear wheel arch.

Repeat for opposite side of vehicle.

8. Carefully unclip and remove rear bumper; disconnecting any applicable wiring looms.

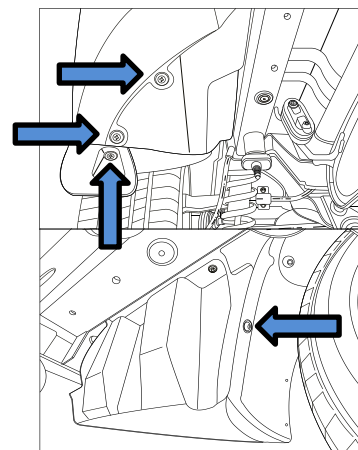

9. Remove 3 x push Rivets securing impact beam bumper tabs to bumper.
10. Remove 2 x clips securing top of impact beam to bumper.
11. Where applicable, release smart key antenna from impact beam.
12. Detach wiring from impact beam and remove and discard impact beam from rear bumper.

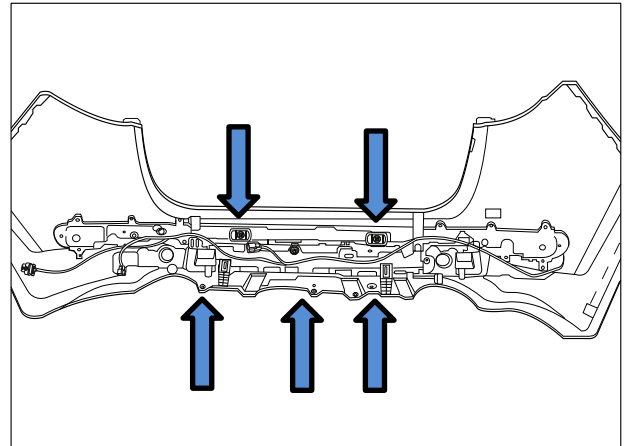

13. Feed 1x Nut plate on wire and 1 x Nutplate into the chassis rail.

Loosely secure the side arm assembly to the side of the chassis rail with 2 x M12 bolts complete with 1 x washer per bolt, and to the underside with 1 x M12 bolt complete with 1 x washer.

Repeat for other side.

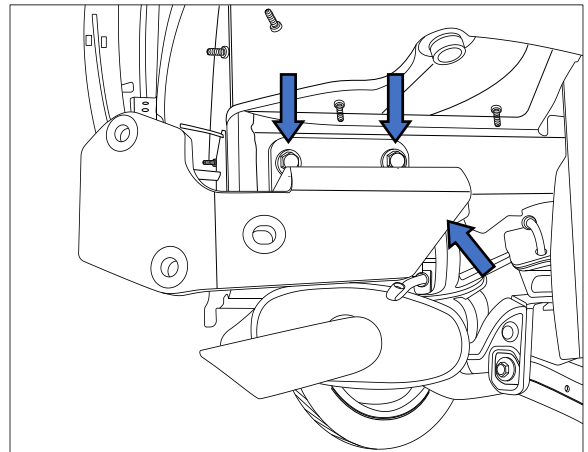

14. Lift cross tube to the side arms and loosely secure each side with 3 x M12 bolts complete with 2 x washers and 1 x nut per bolt.

Position the towbar and torque all bolts.

**M12 : 125Nm.**

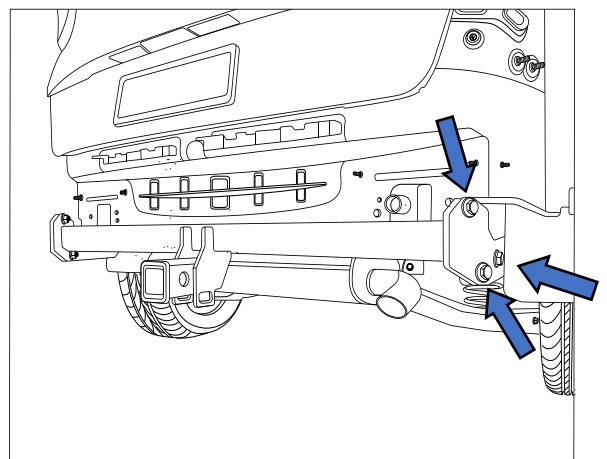

15. Where required, secure smart key antenna brackets to holes in top of towbar using Tek Screws.
16. Secure bumper tab brackets in the top holes on rear face of towbar using Tek screws.

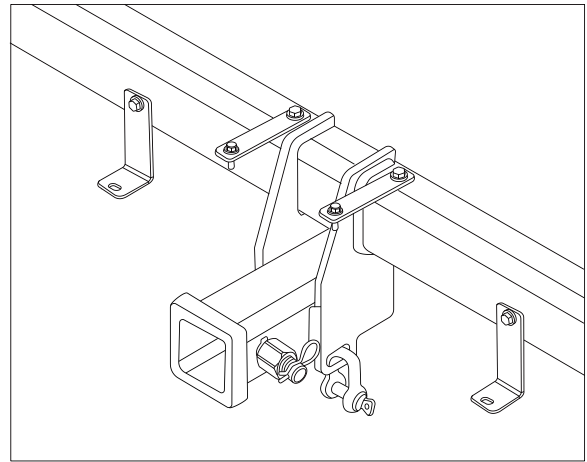

17. Identify centre of bumper and create bumper cut as per diagram shown.

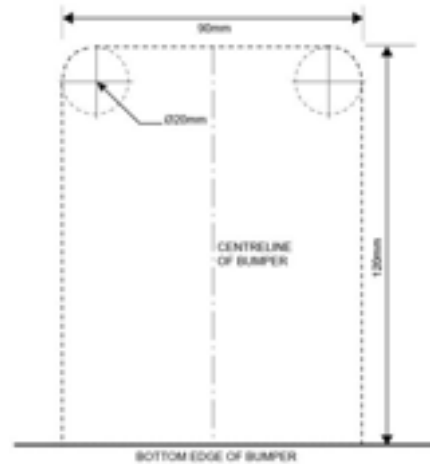

18. Mark out and drill 2x  $\varnothing 5$ mm holes 69mm apart on bumper skin to support plug bracket. Feed bracket threads through drilled holes prior to reinstalling bumper.

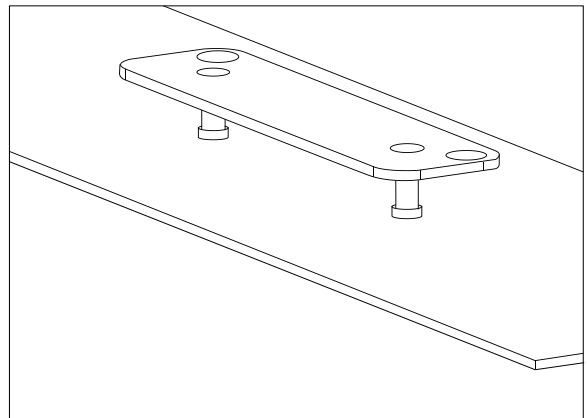

### IMPORTANT

Due to possible vehicle variations, always confirm any noted vehicle colour wires with a multi-meter to ensure the correct function is identified before soldering or scotch locking. For vehicle wires denoted with two colours (example; RED/GREEN) the first colour will always be the main wire colour while the second colour is the thinner trace colour on the wire.

19. Fold down the rear passenger seats (1).

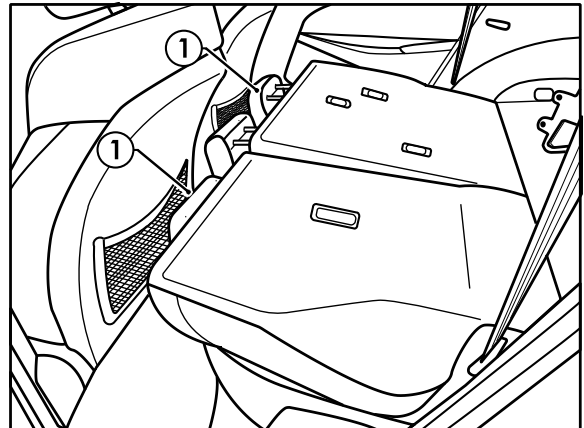

20. Remove the rear sunshade (1).

21. Remove the luggage compartment floor (2).

22. Remove the car jack.

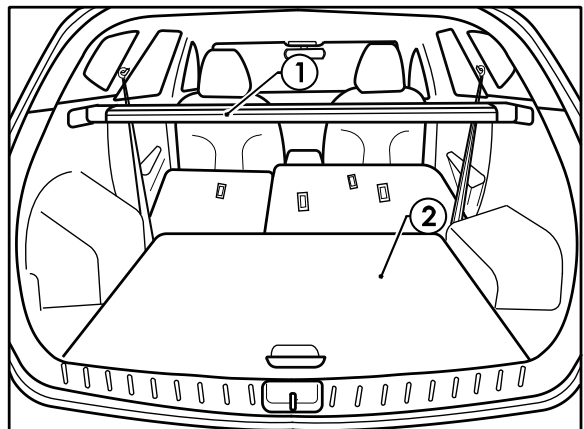



23. Remove the rear scuff trim (1) by first removing the two fasteners (2).

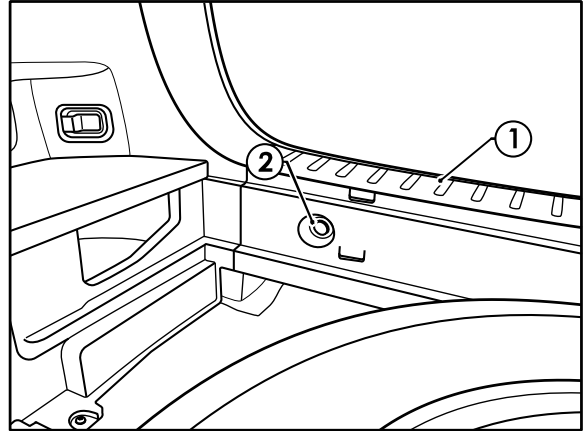

24. Remove the four fasteners (1) from the RHS luggage compartment trim (2) and then dislodge the luggage compartment trim.

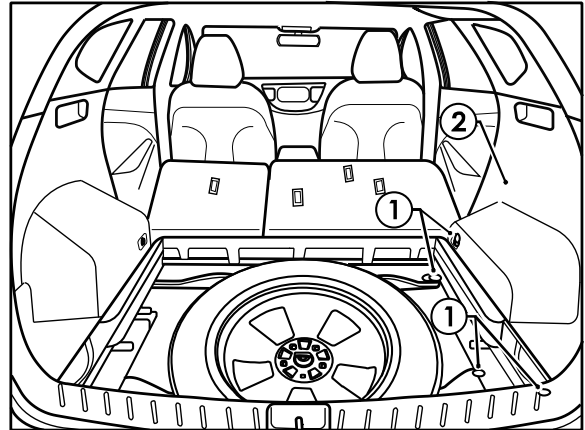

25. Remove rear passenger RHS kick trim (1).

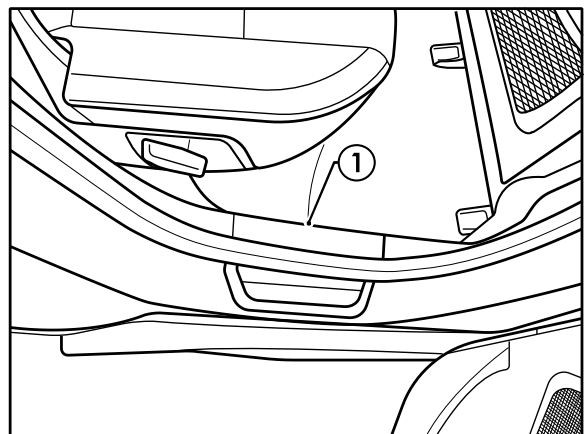

26. Remove the driver's door sill trim (1).

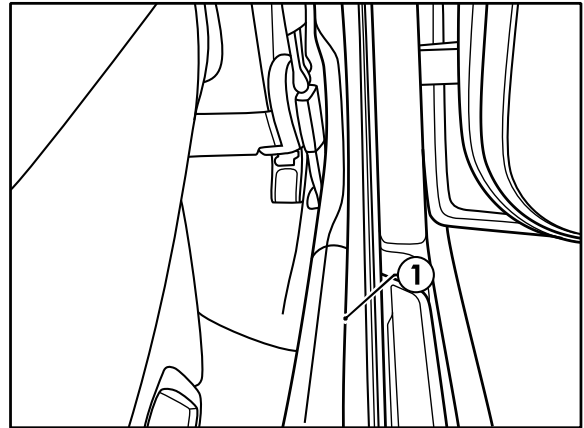

27. Remove the bonnet handle (1) and then remove the driver's kick panel trim (2).

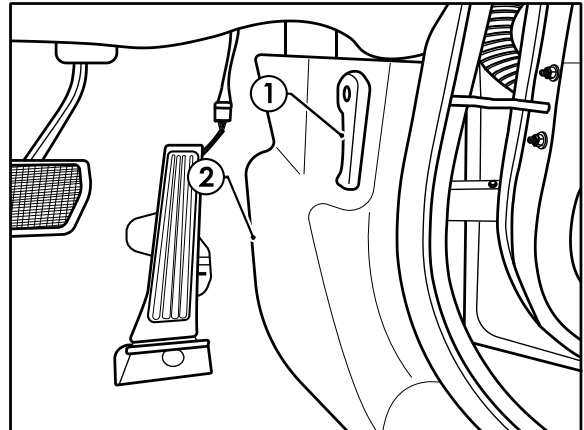

28. From the vehicle interior, retrieve the vehicle RHS taillight connector (1).

29. Route the trailer patch (P/No:102237-WL) connectors to the retrieved RHS taillight connector (1) and connect to the mating trailer patch connector (2).

30. Route the remaining trailer patch connector (3) through the vehicle grommet hole until the trailer patch grommet (4) is seated correctly.

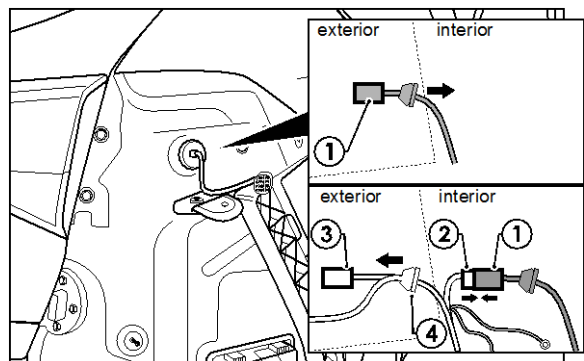

31. Route the trailer patch LHS branch (1) towards the LHS vehicle taillight area and then connect the trailer patch connector to the mating vehicle harness taillight connector (2).

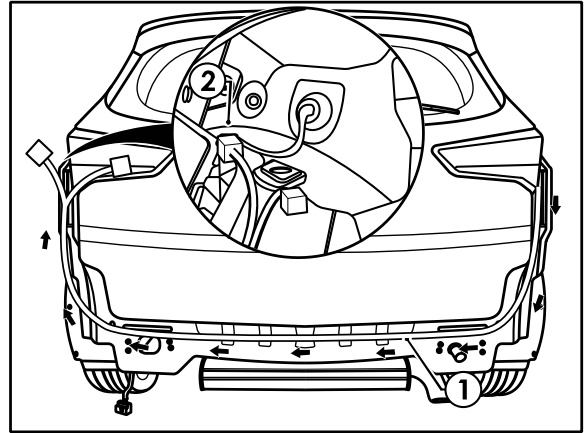

32. At the bumper connector, locate the RPA ground wire (1).
33. Remove 200mm of covering and cut the ground wire.
34. Cut and crimp the GREY & GREY/BLACK wires on the trailer patch in between the ground wire (2).
35. Tape up the covering and secure trailer patch to existing vehicle wiring using Cable Ties.

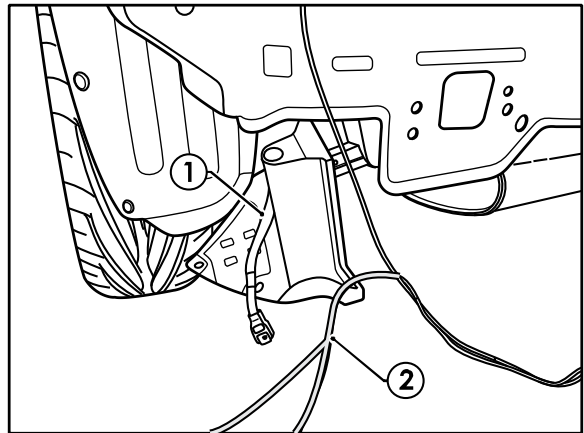

36. Inside the vehicle, pickup the trailer patch on the RHS, using an alcohol wipe, clean the RHS inner sheet metal area (1) and the underside of the ECU (04826).
37. Connect the trailer patch 12-way connector (2) to the ECU.
38. Apply double sided tape to the ECU and secure it to the vehicle sheet metal.

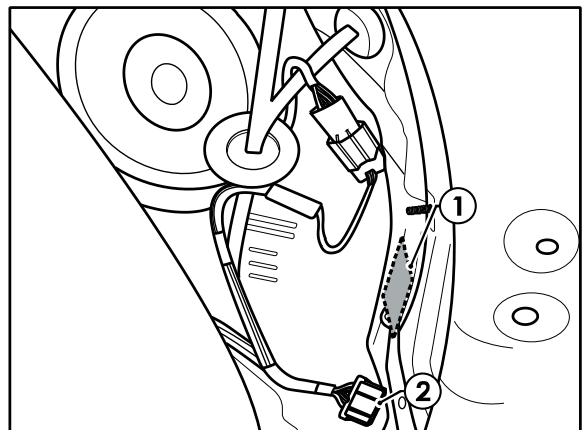

**Note: Mount the ECU, ensuring the connector is orientated downwards.**

- 39. At the C-pillar trim, secure the trailer patch ground ring terminal (1) to the vehicle stud (2).
- 40. Route the trailer patch 1-way connector (3) along the vehicle harness, all the way towards the driver's fuse panel area.

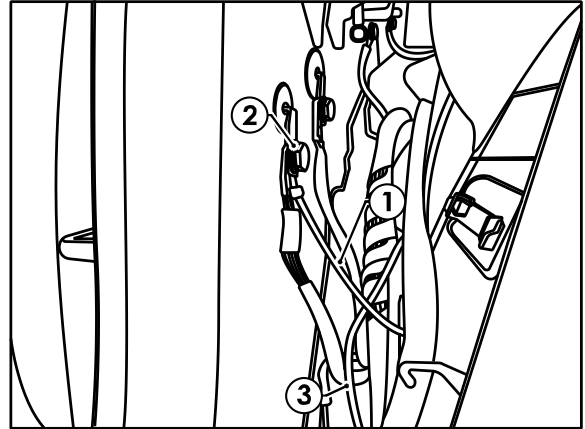

- 41. Remove the indicated vehicle 30A fuse (1). Insert the vehicle fuse 30A fuse (1) and the supplied 20A fuse (2) to the add-a-fuse harness (3). Connect the trailer patch 1-way connector (4) to the add-a-fuse harness (3). Insert the add-a-fuse harness (5) to the previously removed fuse location (6). Ensure the add-a-fuse harness is orientated as shown.

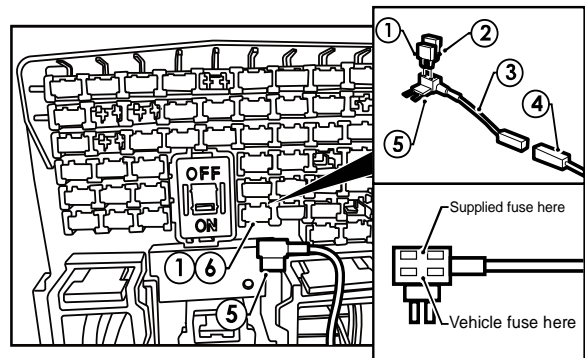

- 42. Secure tail harness to towbar.
- 43. Route the tail harness (tail length: 1200mm) (2) across the RHS and towards the blue connector near the RHS taillight.

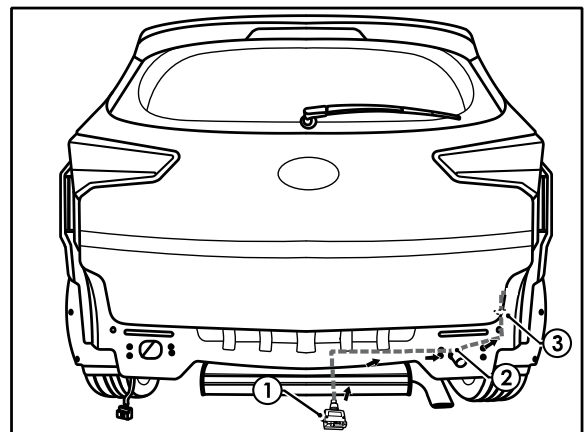

44. Connect the tail harness (tail length 1200mm) 8-way connector (1) to the trailer patch mating 8-way connector (2).
45. Cut-off, crimp the tail harness GREY and GREY/BLACK wires (1) to the trailer patch matching WHITE and GREY/BLACK wires (2).
46. Apply silicone grease (3) (not supplied) to waterproof connector.

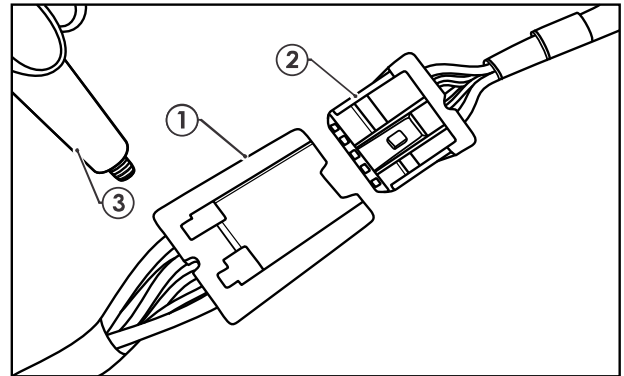

**For RPA Disable (For all Models except Active X):**

47. Strip GREY and GREY/BLACK wires on the trailer patch.
48. Locate the wire which routes to the 20 way bumper connector (connector with male terminals) corresponding to Pin 8 (1).

**Note: Orientation is terminal view**

### Front View

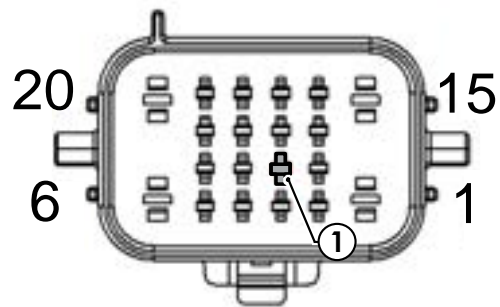

49. Approximately 100mm back from the connector, cut the wire.
50. Crimp the GREY and GREY/BLACK wires on the trailer patch in between the cut wire at the bumper connector and insulate connections.

### Front View

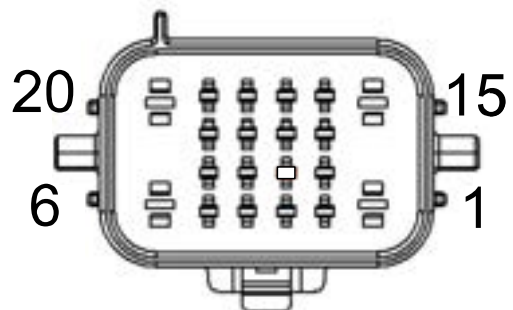

---

**For RPA Disable (Active X Models only):**

51. Step GREY and GREY/BLACK wires on the trailer patch.
52. Locate the wire which routes to the 6 way bumper connector (connector with male terminals) corresponding to Pin 3 (1) (Orange wire).

**Note: Orientation is terminal view.**

### Front View

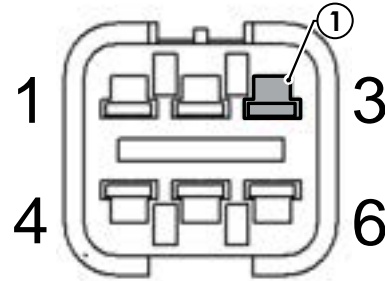

- 
53. Refit taillights. Test the trailer patch function using a light board or multi-meter.
  54. Where applicable, secure smart key antenna to smart key antenna brackets.
  55. Re-fit all removed parts and secure all fasteners, ensuring there are no squeaks or rattles.
  56. Secure loose wiring to towbar using cable ties. The RPA function can be disabled via a switch on the dash board.
  57. Place the fitting instructions in the glove box after fitment.
-



## CUSTOMER INFORMATION

PLACE THESE INSTRUCTIONS IN THE  
VEHICLE'S GLOVEBOX AFTER INSTALLATION

**THANK YOU FOR PURCHASING TRAILBOSS. WITH CORRECT MAINTENANCE AND CARE  
THIS PRODUCT WILL PROVIDE A LIFETIME OF TROUBLE-FREE OPERATION.**

### **TOWBAR MAINTENANCE AND CARE:**

1. Trailboss recommend that the towbar LUG or TBM (Trailer Ball Mount) Pull Pin and R-clip are removed and stored when not in use. Removal of LUG or TBM (Trailer Ball Mount) is advisable when not in use to assist with any of the following.
  - Ensure rear number plate is not obscured.
  - Allow maximum available departure angle and prevent any potential interference.
  - Prevent possible interference with vehicles reverse sensors or camera detecting a tow ball mount as an obstruction during reversing.
  - Removes towball mount as an obstruction for when moving around the rear of the vehicle.
2. Trailboss recommends routine inspection of your towbar to ensure trouble free towing.
  - Bolt security and tension should be regularly inspected and checked for correct tension. Replace any worn or defective parts with suitable grade & class fasteners. Inspection should be requested to coincide with vehicle major services.
3. It is the owner's responsibility to ensure towing and down ball weight capacities of the towing vehicle are not exceeded.
  - Towing and down ball weights allowable may differ according to model variations. Please refer to owner's manual or vehicle dealer to confirm exact rating for your vehicle model variant.
  - It is not uncommon for the vehicle tow rating to differ from the towbar rating. When this occurs, the lesser rating must be adhered to.
  - For vehicles fitted with enhanced vehicle functions that may be altered/changed when towing i.e Trailer sway mitigation, blind spot detection, adaptive cruise control etc. Please consult owner's manual to understand changes enabled when towing and after towing.

### **WARRANTY INFORMATION:**

Trailboss Towbars are covered by a Lifetime Warranty.

Our goods come with guarantees that cannot be excluded under the Australian Consumer Law. You are entitled to a replacement or refund for a major failure and for compensation for any other reasonably foreseeable loss or damage. You are also entitled to have the goods repaired or replaced if the goods fail to be of acceptable quality and the failure does not amount to a major failure.

For further details please contact customer service on 1800 812 017.

## PRO SERIES SILENT ANTI-RATTLE HITCH PIN

Your Trailboss towbar is equipped with a Pro Series Silent Anti-Rattle Hitch Pin technology to help reduce towbar tongue rattle in most driving conditions. Please ensure below instructions are understood and routine maintenance is carried out to ensure best towing experience.

Regularly inspect for wear and check the tightness of the Silent Anti-Rattle Hitch Pin. Follow instructions below to re-tighten the nut as necessary when movement and noise in the tow ball mount is noted.

- Before towing, ensure R-Clip is properly installed and hitch pin nut is installed and tensioned. Replacement parts are available from your Pro Series Distributor.

## TOWBALL MOUNT REMOVAL/INSTALLATION

### STEP 1

Insert Trailer Ball Mount (TBM) (a) into towbar hitchbox (b), aligning hole in TBM shank (c) with hole in hitchbox (d) (Fig. 1)

### STEP 2

Insert Silent Anti-Rattle Hitch Pin (e) through hole in hitchbox and hole in TBM shank (g); ensure the locators are inserted into the notches in the hitchbox (Fig. 2)

### STEP 3

Screw Silent Anti-Rattle Hitch Pin (f) onto Smart Pin (g); tighten Smart Pin Nut until finger tight, ensuring TBM is restrained from up and down movement.

### STEP 4

Tighten Silent Anti-Rattle Hitch Pin Nut by turning nut a further 1/8th of a turn in the clockwise direction using a 24mm spanner (Fig. 4).

### STEP 5

Install Silent Anti-Rattle Hitch Pin R-Clip through the hole that provides best clearance or easiest access. (Fig. 5)

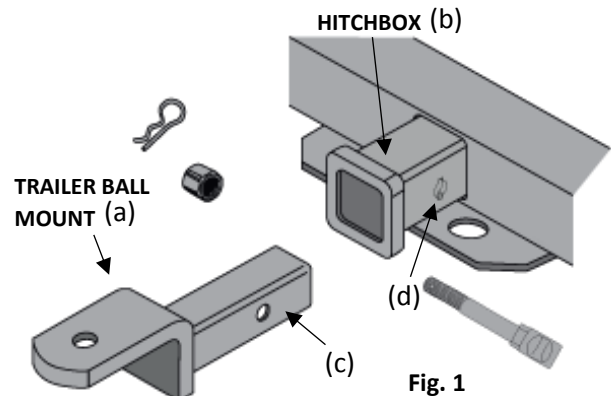

Fig. 1

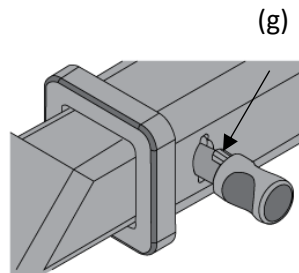

Fig. 2

SILENT ANTI-RATTLE HITCH PIN NUT (f)

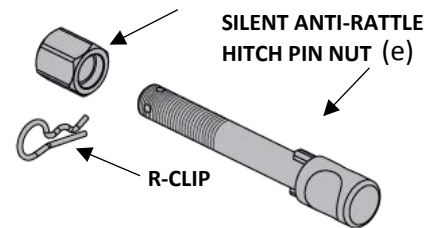

Fig. 3

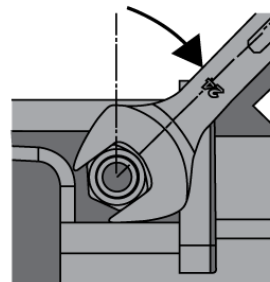

Fig. 4

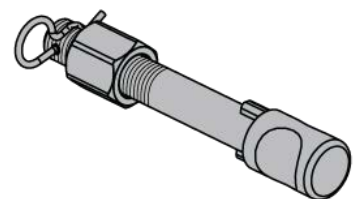

Fig. 5