

PRODUCT DETAILS:

Part Number:	QTHY279L	Maximum Towing Braked:	2500	kg
ECU Number:	04826	Maximum Towing Unbraked:	750	kg
Tail Harness Length Required:	1200 mm	Maximum Static Ball Load:	100	kg
TBM/Lug Part Number:	21161			

FITTING DETAILS:

Towbar Installation Time:	90 Mins.	RPA Disable/Other:	NO
Total Installation Time:	135 Mins.		
Bumper Cut Required:	Yes		

Note:

- RPA disable via switch near transmission lever on vehicle equipped.
- 22 or 7/8 drill bit required for installation.

TRAILBOSS RECOMMENDS THAT INSTRUCTIONS ARE READ AND UNDERSTOOD COMPLETELY PRIOR TO FITMENT.

BEFORE YOU START:

Check all hardware items have been included refer to assembly diagram.
Please ensure this towbar is only fitted to vehicle models as per Trailboss application guide.

Bumper Cuts

Vehicle and bumper variations can and do occur during vehicle manufacture after initial towbar design. Fitment of towbar to vehicle and accuracy of bumper cut must be assessed prior to any bumper modifications made. Incorrect bumper cuts are not covered under Trailboss warranty.

NOTE: Bumper cuts need to be approached with care, refer to notes below.

- Bumper centreline – where the centreline of the bumper needs to be determined, the installer must assess centre point by measurement of bumper width or determining two symmetrical reference points to give centreline.
- Bumper edge – To assist with accurate bumper cut measurement, reference to the start of the bumper edge is now being commonly used.
 - Measure from bottom edge along bumper and around corner to the 70 mm point (Figure 1).
 - Do not measure from visible bumper front of corner, upwards (Figure 2).

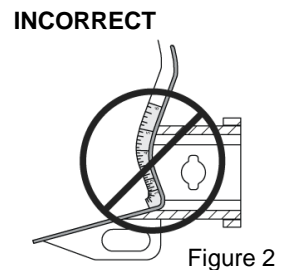
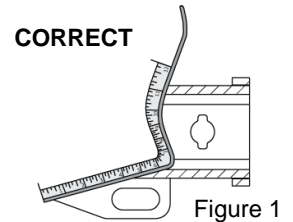

Drilling

- For any required drilling during installation, ensure that the area is clear of fuel, electrical & other components that may be damaged.
- All holes drilled into metal body panels shall have all burrs & swarf removed then coated with a suitable rust preventative paint.

Bolts/Fasteners

- Ensure that all hardware is fastened to correct torque as specified in this fitting instruction.
- All fasteners supplied with this product are used to achieve a specified clamp loading. If replacement is required ensure that fasteners of the same grade and class are used.

NOTE: Achieving correct torque is critical to proper installation and responsibility of the installer. Towbar failures attributed to tension issues from over tightening or under tightening are not covered by Trailboss warranty.

Product Labels

- a. Towbar load rating sticker provided with this product shall be conspicuously located on inside rear end of the driver's door.

WARNING:

Do not, drill, cut, weld or otherwise modify the towbar.

FOR TOWING PURPOSES ONLY - This towbar is designed and tested by Trailboss to adhere to ADR 62/02 which provides only for the expected load demands of towing.

i TOWBAR ASSEMBLY DIAGRAM

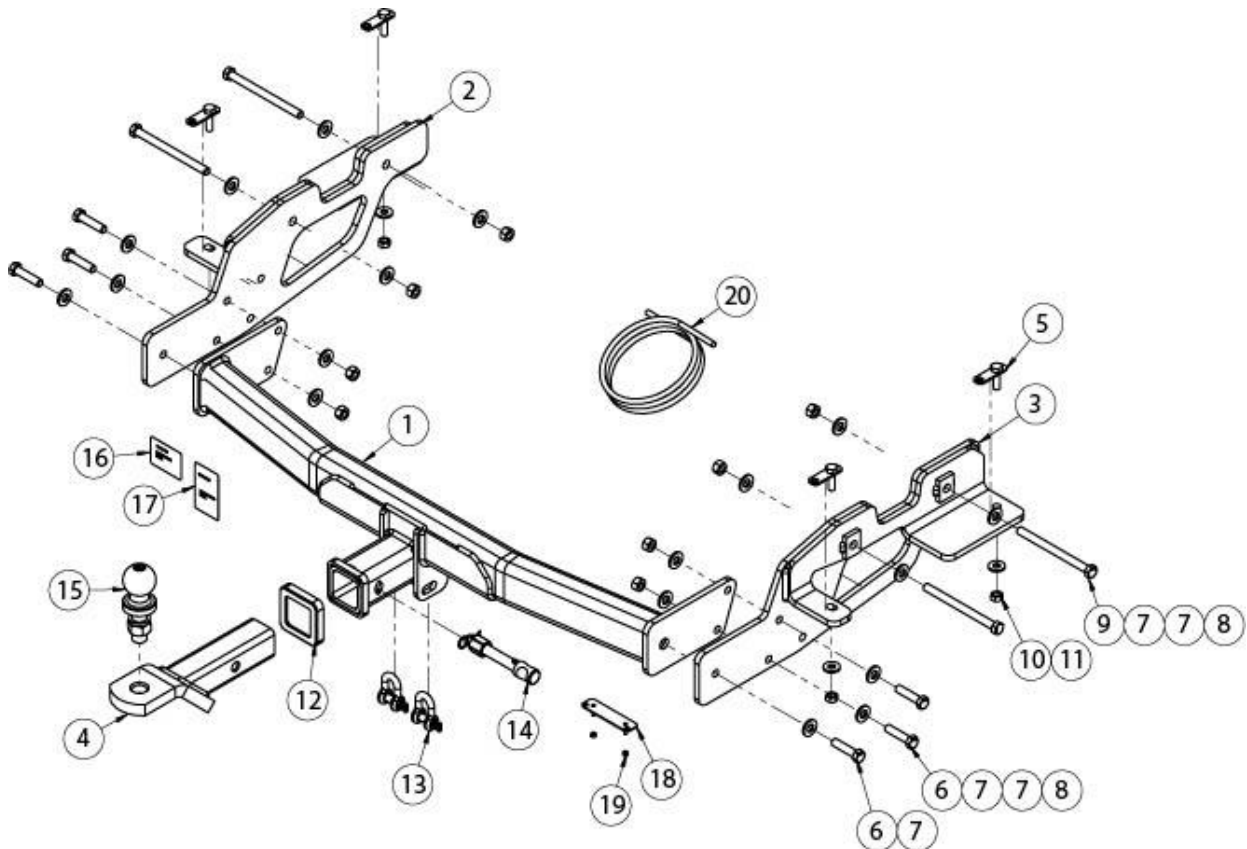

ITEM	DESCRIPTION	QTY
1	HYUNDAI STARIA WELDED ASSEMBLY	1
2	SIDE ARM LHS ASSY	1
3	SIDE ARM RHS ASSY	1
4	TRAILER BALL MOUNT	1
5	T BOLT ASSEMBLY	4
6	BOLT HEX HD M12x50x1.75P	6
7	WASHER PLAIN 1/2"	18
8	NUT HEX HD M12x1.75P	8
9	BOLT HEX HD M12x150x1.75P	4
10	NUT HEX HD M10x1.5P	4

ITEM	DESCRIPTION	QTY
11	WASHER PLAIN M10x25x3	4
12	HITCH BOX COLLAR COVER	1
13	"D" SHACKLE 10mm	2
14	SMART PIN SILVER	1
15	TOWBALL 50mm	1
16	COMPLIANCE LABEL	1
17	LOAD RATING LABEL	1
18	PLUG BRACKET	1
19	NUT NYLOC HEX HD M4x0.7P	2
20	WIRING LOOM	1

-
1. Remove 3x Screws from taillight.

Repeat for the other side.

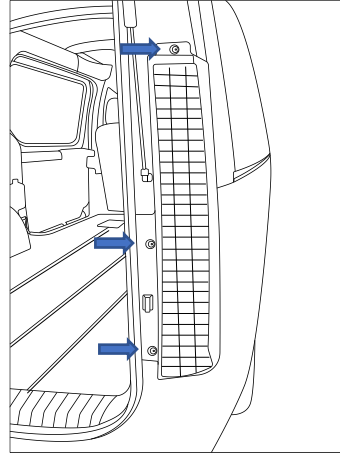

-
2. Pull the taillight rear ward and disconnect wiring.

Repeat for the other side.

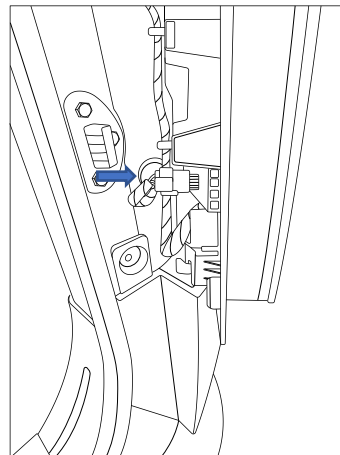

-
3. Remove 3 x Scrivet Clips connecting the rear bumper.

Repeat for the other side.

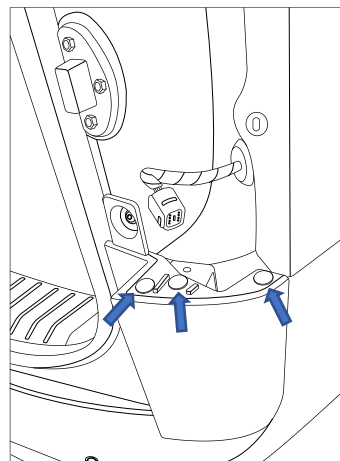

-
4. Remove 1x screws and 2x scrivet clips connecting wheel arch liner to the rear bumper.

Repeat for other side.

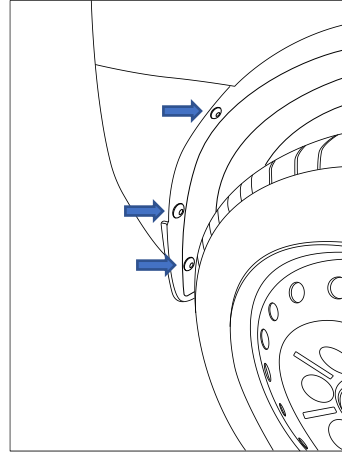

-
5. Remove 3x scrivet clips connecting the connecting wheel arch liner to the rear bumper.

Repeat for other side.

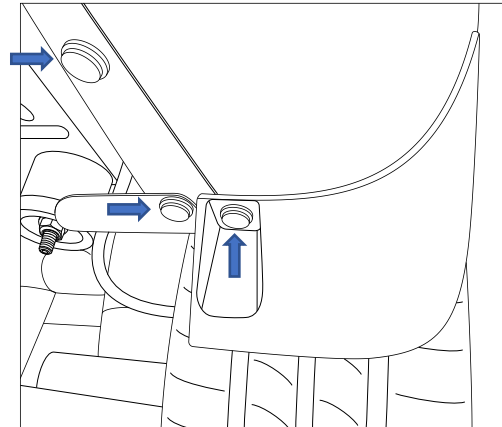

-
6. Remove 2 x Bolts connecting the rear impact beam to the vehicle.

Repeat for other side.

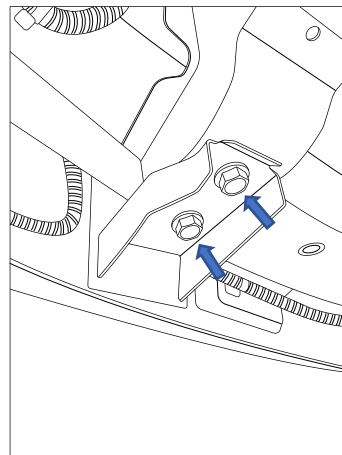

-
7. Disconnect the wiring harness located on the LHS of the rear bumper.

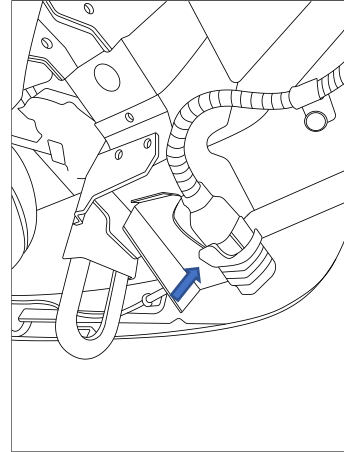

-
8. Unclip the rear bumper.
Repeat for the other side.

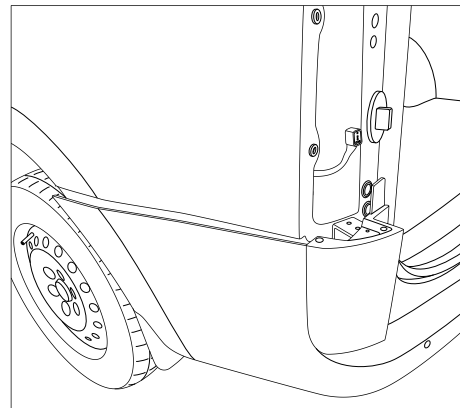

-
9. Remove the rear bumper,
Store safely to avoid damage to the rear bumper.

-
10. Lower the tyre out of the cradle using the factory tool kit and remove the spare wheel from the vehicle.

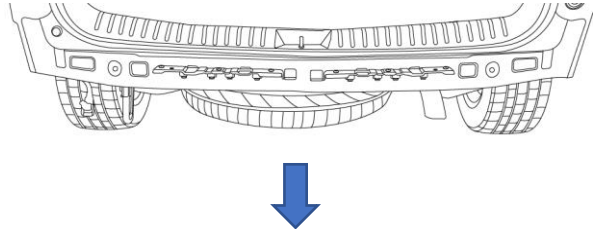

-
11. Remove Exhaust from hanger.

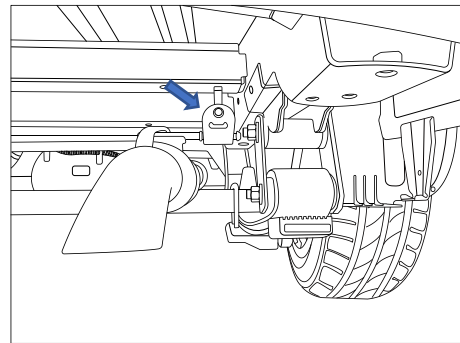

-
12. Remove the Grommet covering the hole under the chassis rail. Insert T-Bolt through the uncovered hole.

Repeat for the other side.

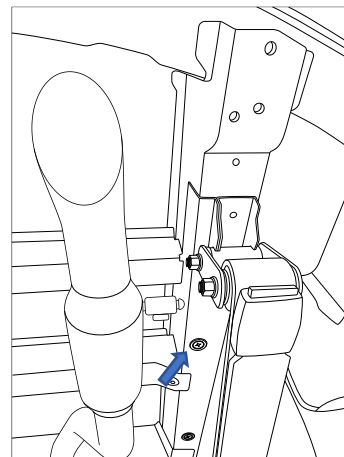

-
13. Attach the RH Sidearm to chassis rail by inserting the 2 x M12 x 150 Bolts, ensuring the T-Bolt is sticking through – Using 1x M10 Washer and 1 X M10 Nut, and 2 x M12 Washers and 2 X M12 Nuts, and tighten the Side Arm to the chassis rail.

Repeat for the other side.

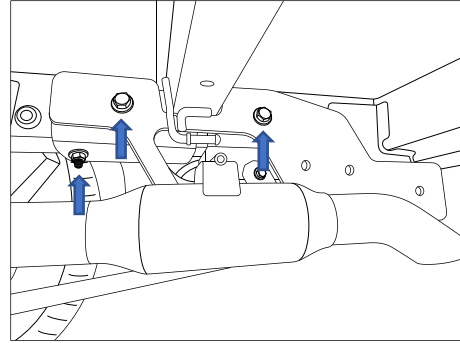

-
14. Mark out the inside of the front slot on the Chassis rail. Using a 5mm drill bit, drill a pilot hole.

Remove the side arm and drill a 23mm hole using the pilot hole as the centre guide, (Gradually increase the drill bit size).

Note: Ensure that the bare metal surfaces is coated in bare metal primer and touch up paint or suitable automotive rust inhibitor.

Repeat for the other side.

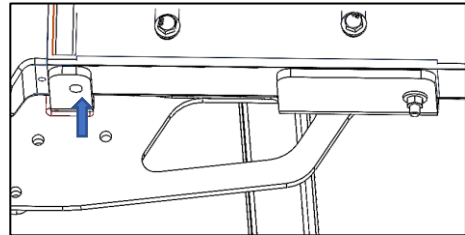

-
15. Insert the additional T-Bolt into the drilled hole.

Repeat of the other side.

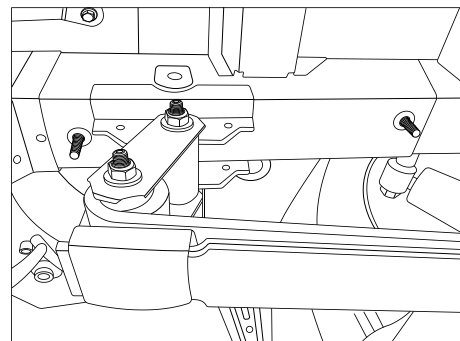

-
16. Refit the Sidearm to the chassis rail by inserting the 2 x M12 x 150 Bolts, ensuring the T-Bolts are sticking through – Loosely secure to the Chassis Rail using 2x M10 Washer and 2 X M10 Nut, and 2 x M12 Washers and 2 X M12 Nuts.

Repeat for the other side.

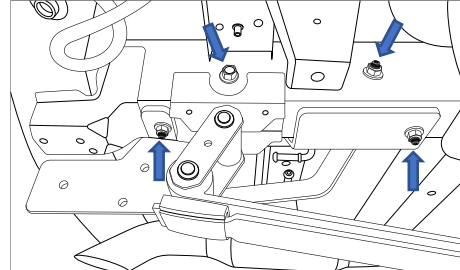

-
17. Fit the towbar to the side arms and loosely secure using 3 x M12 x 50 Bolts, 5 x M12 Washers and 2 x M12 Nuts

Repeat for the other side.

18. Torque all fasteners as assembled in steps 16 & 17 on both sides as follows:

M12 x 1.75P = 109Nm

M10 x 1.5P = 44Nm

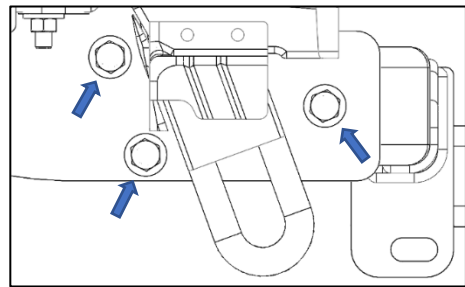

-
19. On the rear bumper, If present, remove 2 x screws holding the key sensor antenna.

Remove 2 x bumper scrivets and unscrew the 1x screw connecting to the support beam.

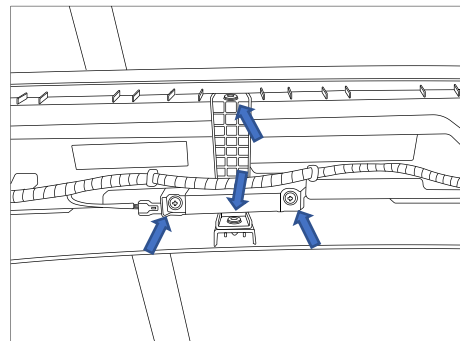

20. Remove material from the hard plastic support on the rear bumper interior as shown a depth of 12mm.

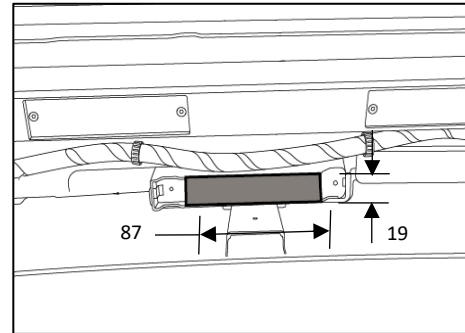

21. Place masking tape on the bumper outer skin, Mark and cut out an area as shown to clear the hitch box.

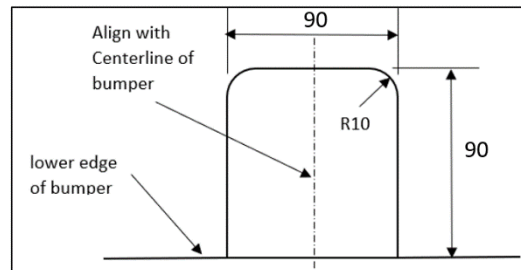

22. Cable Tie the key sensor antenna out of the way of the towbar opening as shown.

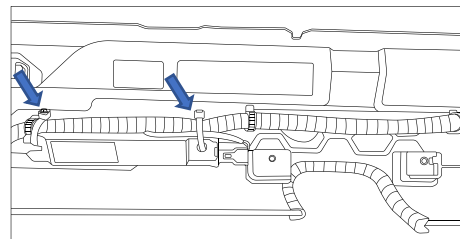

IMPORTANT

Due to possible vehicle variations, always confirm any noted vehicle colour wires with a multi-meter to ensure the correct function is identified before soldering or scotch locking. For vehicle wires denoted with two colours (example; RED/GREEN) the first colour will always be the main wire colour while the second colour is the thinner trace colour on the wire.

23. In the engine bay, disconnect the vehicle battery negative terminal (1).

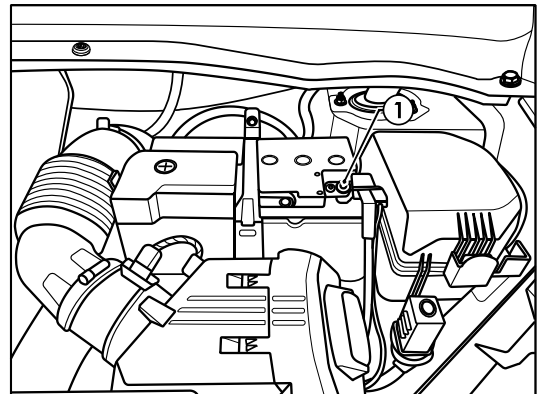

24. At the rear of the vehicle, remove three Phillips Head Screws (1) securing the tail lamps.
25. Dislodge the tail lamps (2) and disconnect the connectors before removing both tail lamp assemblies.
26. Remove Rear Scuff plate (3).

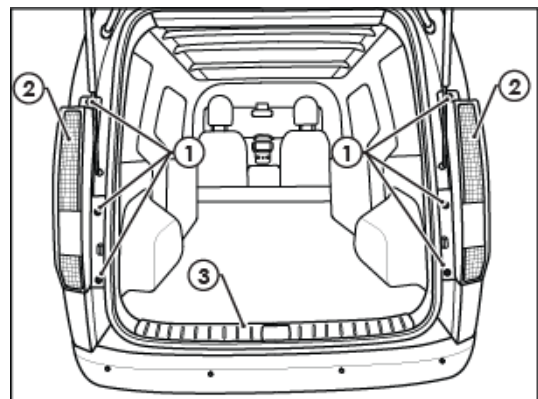

**Proceed with Steps 3 through to 27 for the Staria Load Variant.
For Staria People Mover variant, skip to Step 28.**

27. The following Steps are for the Staria Load Variant.
 1 Proceed to Step 8 for Staria People Mover.
28. From inside the vehicle, remove 12 scrivets (1) from the RHS luggage compart trim (2).
29. Remove the RHS luggage compart trim (2).

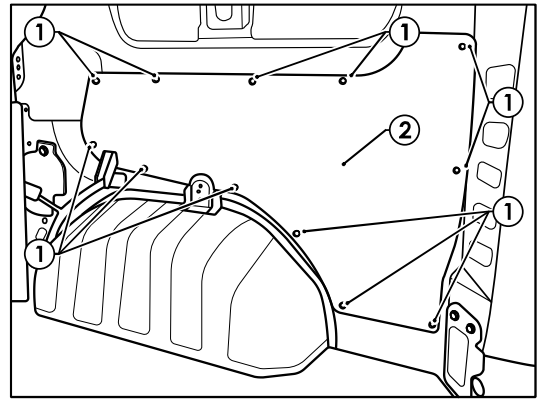

30. Secure the white M6 ground wire ring terminal to the vehicle earthing point (1) on the luggage compartment RHS.
31. Route the Trailer Wiring Harness following the existing factory vehicle harness (2).

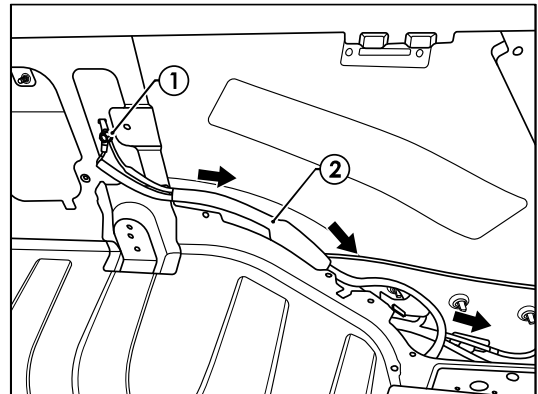

32. Clean ECU mounting location (1) shown and base of ECU (2) using supplied cleaning pad.
33. Connect the Trailer Harness 12-Way Connector (3) to ECU (2) and mount in the location shown using the supplied Double-Sided Tape.
34. Secure Trailer Harness (4) to existing Vehicle Harness using supplied 200mm Cable ties.

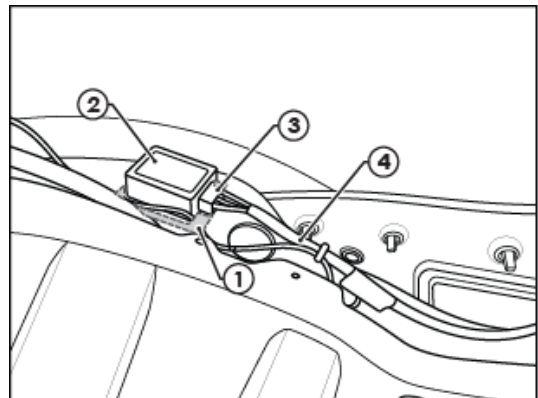

35. Proceeding with this step if the 13-way pre-wire connector is available.
36. Remove the tape covering the 13-way male connector (1) from the vehicle harness.
37. Remove and discard the 13-way blanking plug if present.
38. Connect the Trailer Wiring Harness 13-way female connector (2) to the vehicle harness 13-way male connector (1).
39. Secure the un-used 8-way female connector to the main harness using PVC tape.

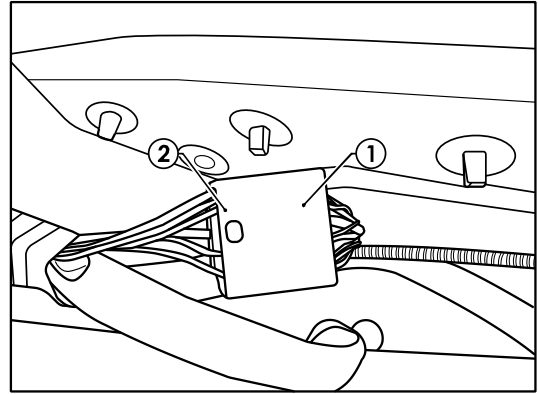

40. Proceeding with this step if the 8-way pre-wire connector is available.
41. Locate the vehicle 8-way prewire connector (1) on the vehicle harness.
42. Remove the tape covering the 8-way prewire connector from the vehicle harness.
43. Remove and discard the 8-way blanking plug if present.
44. Connect the the 8-way female connector (2) of the trailer patch to the vehicle 8-way pre-wire connector (1).
45. Secure the un-used 13-way female connector to the main harness using PVC tape.

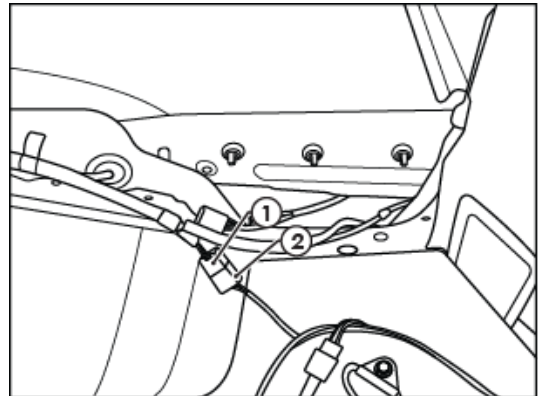

46. Proceed with Steps 8 to Step14 for the Staria People Mover variant.
47. At the Rear RHS of the vehicle, remove the cover from the RHS third row seatbelt upper bolt (1).
48. Remove the seatbelt upper bolt (1) and dislodge the seatbelt.
49. Open the RHS third-row glass window (2) and remove the D-pillar inner trim (3).

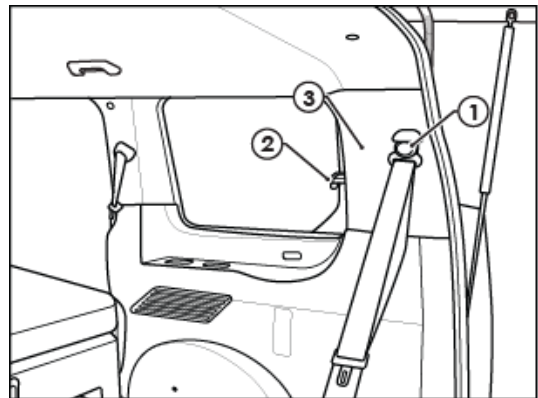

50. Remove the RHS C Pillar air bag trim cap (1) and 10 mm bolt underneath it.
51. Dislodge and remove the RHS C Pillar trim (2).

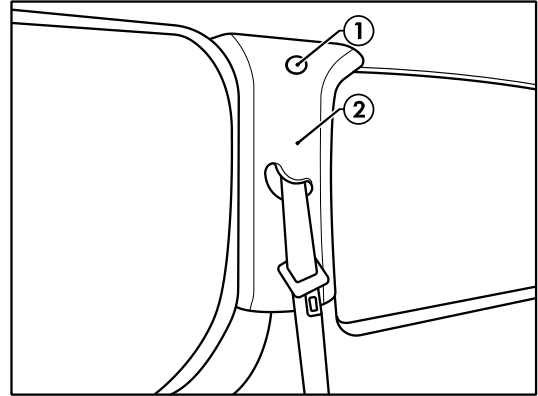

52. Remove RHS Second row seat belt bolt cover (1) and 14mm bolt.

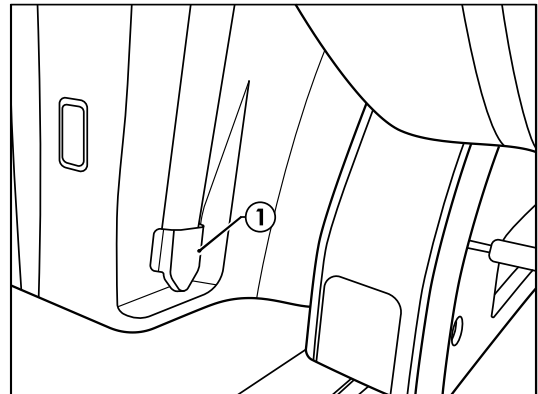

53. Lay the second and third row seats down and move them forwards.
54. Remove the RHS third row seat belt bolt cover (1).
55. Remove 14mm third row seat belt bolt (2).
56. Remove the plastic bolt cover (3).
57. Remove four M6 bolts (4).
58. Dislodge and remove the rear compartment trim (5).

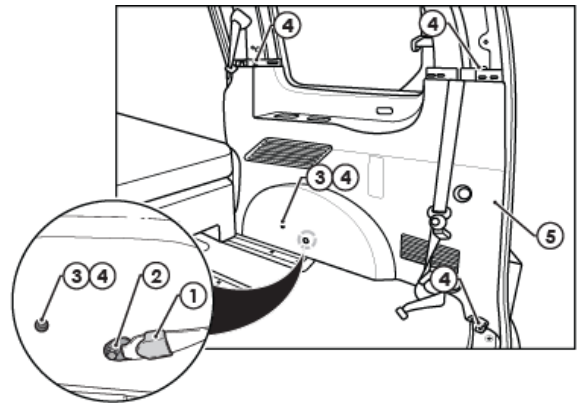

59. Proceeding with this step if the 13-way pre-wire connector is available.
60. Locate the 13-way male vehicle connector (1) and remove 13-way blanking plug.
61. Connect the 13-way female connector on the trailer wiring harness to the 13-way on the vehicle harness.
62. Route the trailer wiring harness towards the front of the vehicle and secure the M6 ground wire ring terminal to the vehicle earthing point.
63. Secure the un-used 8-way female connector to the main harness using PVC tape

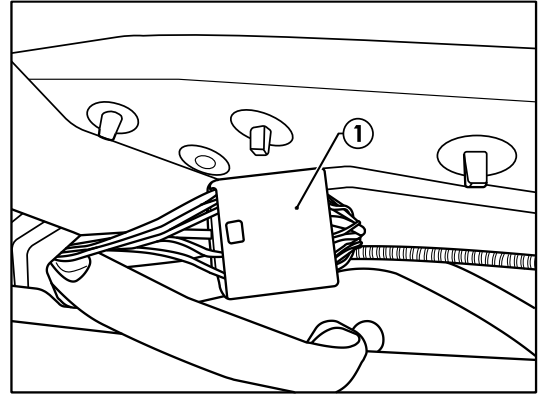

64. Clean ECU mounting location (1) shown and base of ECU (2) using supplied cleaning pad.
65. Connect the Trailer Harness 12-Way Connector (3) to ECU (2) and mount in the location shown using the supplied Double-Sided Tape

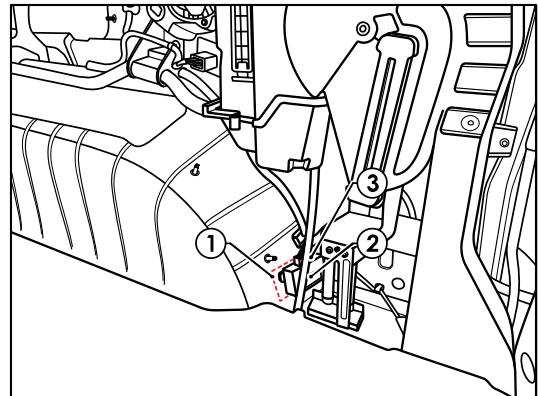

66. Unseat the the grommet (1) and push the harness (2) with the grommet inside the vehicle.
67. With the blanking grommet removed, feed through 1200mm tail harness with the blue connector and ensure the grommet (3) is properly seated.

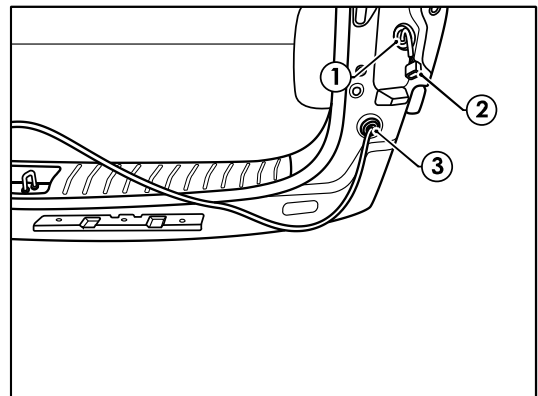

68. From inside, route the trailer patch towards the RHS rear of the vehicle.
69. Connect the 10-way male connector of the trailer patch to the RHS tail light connector previously pushed inside in Step 15.
70. Feed the 10-way female connector (1) of the trailer patch together with branch (2) and the 2x female terminal through the grommet hole and ensure the grommet (3) is properly seated.

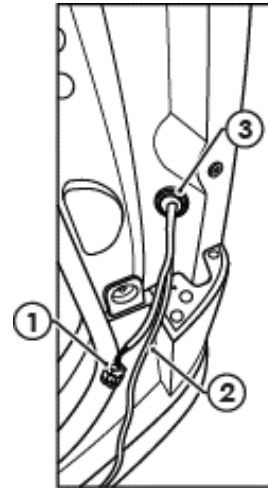

Important



Use guide wire if required to help feeding the harness through the grommet hole when fitting on People Mover variant.

71. Connect the 10-way female connector to the RHS vehicle tail light.
72. With the rear bumper removed, route the branch (1) with the 2x female terminal across the rear of the vehicle to the LHS tail light connector.

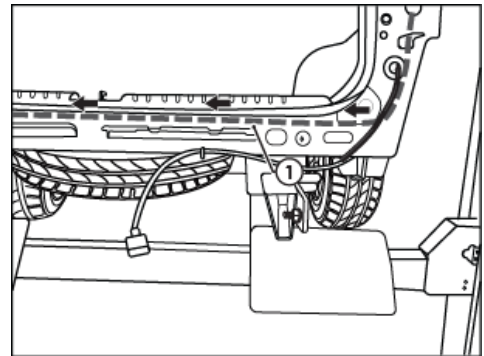

73. Approximately 100mm from the back of the LHS vehicle tail light connector (1), strip the tape covering the tail light harness.
74. Following the LHS tail light table and pinout diagram, connect the supplied EZY-Taps to the LHS tail light wires.
75. Connect the female terminals from the trailer patch to the EZYTaps following the table and pinout diagram.

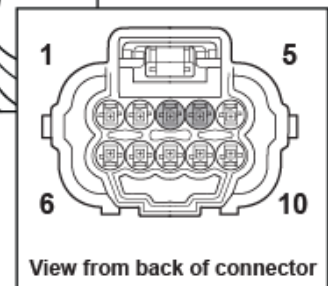
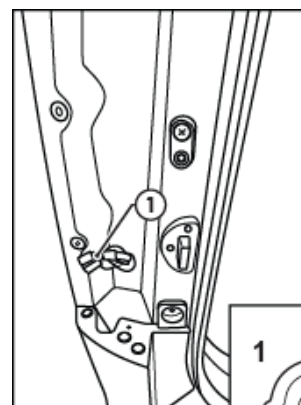

Connector Pin No.	FUNCTION	VEHICLE HARNESS	TRAILER PATCH
3	LHS Indicator	Grey	Yellow/Black
4	Reverse	Red/Black	Black/White

76. Cover the exposed section of the tail light harness using PVC tape.

77. In the vehicle, connect the tail harness (tail length 1200mm) 8-way connector (1) to the trailer patch mating 8-way connector (2) and secure the tail harness to the tow bar.
78. Secure all harness using supplied cable ties.
79. Reconnect negative battery terminal.
80. Re-fit all removed parts and secure all fasteners, ensuring there are no squeaks or rattles.
81. The RPA function can be disabled via a switch next to the gear shifter.
82. Test the trailer patch function using a light board or multimeter.
83. Place the fitting instructions in the glove box after fitment.

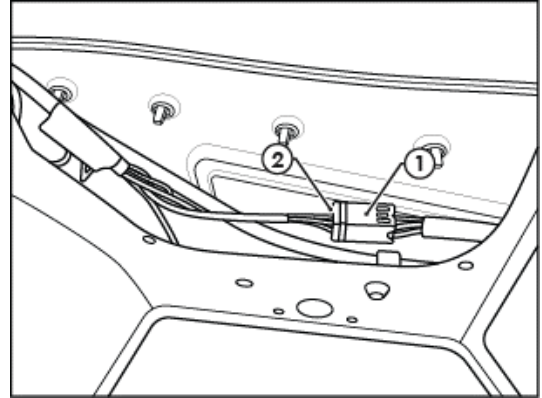



CUSTOMER INFORMATION

PLACE THESE INSTRUCTIONS IN THE VEHICLE'S GLOVEBOX AFTER INSTALLATION

THANK YOU FOR PURCHASING TRAILBOSS. WITH CORRECT MAINTENANCE AND CARE THIS PRODUCT WILL PROVIDE A LIFETIME OF TROUBLE-FREE OPERATION.

TOWBAR MAINTENANCE AND CARE:

1. Trailboss recommend that the towbar LUG or TBM (Trailer Ball Mount) Pull Pin and R-clip are removed and stored when not in use. Removal of LUG or TBM (Trailer Ball Mount) is advisable when not in use to assist with any of the following.
 - Ensure rear number plate is not obscured.
 - Allow maximum available departure angle and prevent any potential interference.
 - Prevent possible interference with vehicles reverse sensors or camera detecting a tow ball mount as an obstruction during reversing.
 - Removes towball mount as an obstruction for when moving around the rear of the vehicle.
2. Trailboss recommends routine inspection of your towbar to ensure trouble free towing.
 - Bolt security and tension should be regularly inspected and checked for correct tension. Replace any worn or defective parts with suitable grade & class fasteners. Inspection should be requested to coincide with vehicle major services.
3. It is the owner's responsibility to ensure towing and down ball weight capacities of the towing vehicle are not exceeded.
 - Towing and down ball weights allowable may differ according to model variations. Please refer to owner's manual or vehicle dealer to confirm exact rating for your vehicle model variant.
 - It is not uncommon for the vehicle tow rating to differ from the towbar rating. When this occurs, the lesser rating must be adhered to.
 - For vehicles fitted with enhanced vehicle functions that may be altered/changed when towing i.e Trailer sway mitigation, blind spot detection, adaptive cruise control etc. Please consult owner's manual to understand changes enabled when towing and after towing.

WARRANTY INFORMATION:

Trailboss Towbars are covered by a Lifetime Warranty.

Our goods come with guarantees that cannot be excluded under the Australian Consumer Law. You are entitled to a replacement or refund for a major failure and for compensation for any other reasonably foreseeable loss or damage. You are also entitled to have the goods repaired or replaced if the goods fail to be of acceptable quality and the failure does not amount to a major failure. For further details please contact customer service on 1800 812 017.

PRO SERIES SILENT ANTI-RATTLE HITCH PIN

Your Trailboss towbar is equipped with a Pro Series Silent Anti-Rattle Hitch Pin technology to help reduce towbar tongue rattle in most driving conditions. Please ensure below instructions are understood and routine maintenance is carried out to ensure best towing experience.

Regularly inspect for wear and check the tightness of the Silent Anti-Rattle Hitch Pin. Follow instructions below to re-tighten the nut as necessary when movement and noise in the tow ball mount is noted.

- Before towing, ensure R-Clip is properly installed and hitch pin nut is installed and tensioned. Replacement parts are available from your Pro Series Distributor.

TOWBALL MOUNT REMOVAL/INSTALLATION

STEP 1

Insert Trailer Ball Mount (TBM) (a) into towbar hitchbox (b), aligning hole in TBM shank (c) with hole in hitchbox (d) (Fig. 1)

STEP 2

Insert Silent Anti-Rattle Hitch Pin (e) through hole in hitchbox and hole in TBM shank (g); ensure the locators are inserted into the notches in the hitchbox (Fig. 2)

STEP 3

Screw Silent Anti-Rattle Hitch Pin Nut (f) onto Smart Pin (g); tighten Smart Pin Nut until finger tight, ensuring TBM is restrained from up and down movement.

STEP 4

Tighten Silent Anti-Rattle Hitch Pin Nut by turning nut a further 1/8th of a turn in the clockwise direction using a 24mm spanner (Fig. 4).

STEP 5

Install Silent Anti-Rattle Hitch Pin R-Clip through the hole that provides best clearance or easiest access. (Fig. 5)

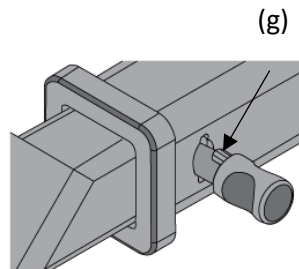
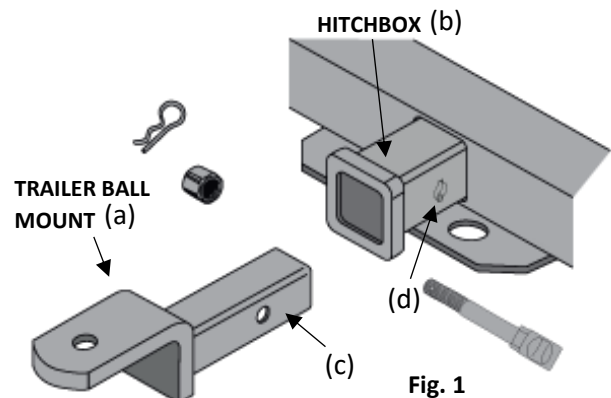

Fig. 2

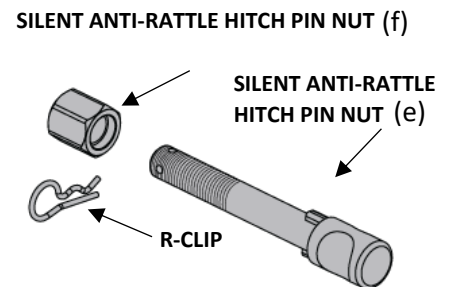

Fig. 3

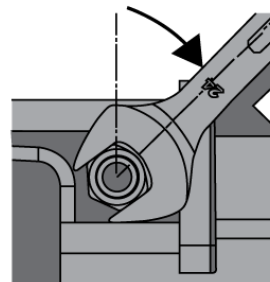

Fig. 4

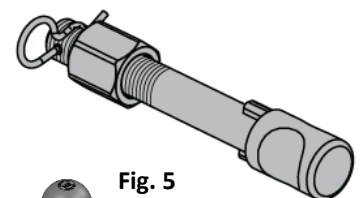

Fig. 5

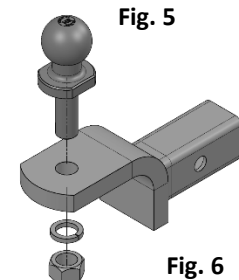

Fig. 6