

**PRODUCT DETAILS:**

Part Number:	QTIS5L	Maximum Towing Braked:	3500	kg
ECU Number:	04835	Maximum Towing Unbraked:	750	kg
Tail Harness Length Required:	See Note	Maximum Static Ball Load:	350	kg
TBM/Lug Part Number:	21161			

**FITTING DETAILS:**

Towbar Installation Time:	40 Mins.	RPA Disable/Other:	YES
Total Installation Time:	60 Mins.		
Bumper Cut Required:	No		

**Note:**

- 04943 tail must be used to disable RPA **where equipped**.
- This towbar suits vehicles where OEM plastic bumper bar will be removed and discarded. Blind spot sensor relocation will be required.

### TRAILBOSS RECOMMENDS THAT INSTRUCTIONS ARE READ AND UNDERSTOOD COMPLETELY PRIOR TO FITMENT.

#### BEFORE YOU START:

Check all hardware items have been included refer to assembly diagram.  
Please ensure this towbar is only fitted to vehicle models as per Trailboss application guide.

#### Bumper Cuts

Vehicle and bumper variations can and do occur during vehicle manufacture after initial towbar design. Fitment of towbar to vehicle and accuracy of bumper cut must be assessed prior to any bumper modifications made. Incorrect bumper cuts are not covered under Trailboss warranty.

**NOTE: Bumper cuts need to be approached with care, refer to notes below.**

- Bumper centreline – where the centreline of the bumper needs to be determined, the installer must assess centre point by measurement of bumper width or determining two symmetrical reference points to give centreline.
- Bumper edge – To assist with accurate bumper cut measurement, reference to the start of the bumper edge is now being commonly used.
  - Measure from bottom edge along bumper and around corner to the 70 mm point (Figure 1).
  - Do not measure from visible bumper front of corner, upwards (Figure 2).

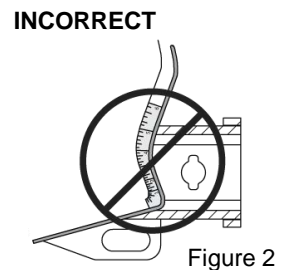
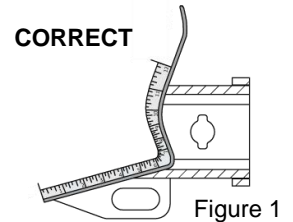

#### Drilling

- For any required drilling during installation, ensure that the area is clear of fuel, electrical & other components that may be damaged.
- All holes drilled into metal body panels shall have all burrs & swarf removed then coated with a suitable rust preventative paint.

#### Bolts/Fasteners

- Ensure that all hardware is fastened to correct torque as specified in this fitting instruction.
- All fasteners supplied with this product are used to achieve a specified clamp loading. If replacement is required ensure that fasteners of the same grade and class are used.

**NOTE: Achieving correct torque is critical to proper installation and responsibility of the installer. Towbar failures attributed to tension issues from over tightening or under tightening are not covered by Trailboss warranty.**

#### Product Labels

- a. Towbar load rating sticker provided with this product shall be conspicuously located on inside rear end of the driver's door.

### WARNING:

**Do not, drill, cut, weld or otherwise modify the towbar.**

**FOR TOWING PURPOSES ONLY - This towbar is designed and tested by Trailboss to adhere to ADR 62/02 which provides only for the expected load demands of towing.**

### **i** TOWBAR ASSEMBLY DIAGRAM

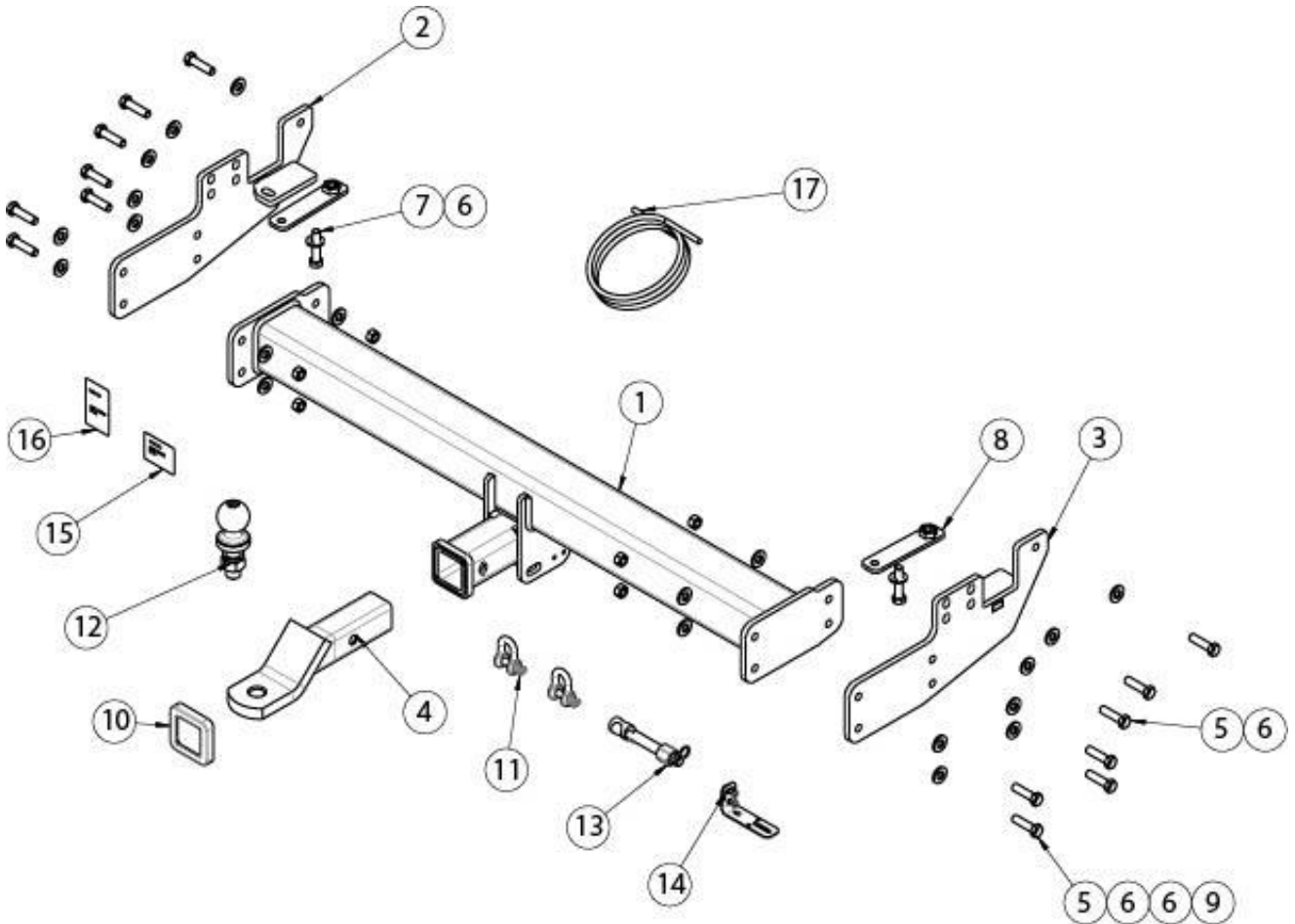

ITEM	DESCRIPTION	QTY
1	ISUZU DMAX CAB CHASSIS	1
2	SIDE ARM WELDMENT LHS	1
3	SIDE ARM WELDMENT RHS	1
4	TRAILER BALL MOUNT	1
5	SET SCREW HEX HD M12x45x1.25P	14
6	WASHER PLAIN 1/2"	24
7	BOLT HEX HD M12x55x1.75P	2
8	NUT PLATE WELDED ASSEMBLY	2
9	NUT HEX HD M12x1.25P	8

ITEM	DESCRIPTION	QTY
10	HITCH BOX COLLAR COVER	1
11	"D" SHACKLE 10mm	2
12	TOWBALL 50mm	1
13	SMART PIN SILVER	1
14	UNIVERSAL PLUG BRACKET KIT	1
15	COMPLIANCE LABEL	1
16	LOAD RATING LABEL	1
17	WIRING LOOM	1

1. Remove and discard 4x bolts mounting the rear step from the chassis.  
Remove and retain the rear LHS and RHS sensor from the rear step.



NOTE:

Sensor brackets kit sold separately

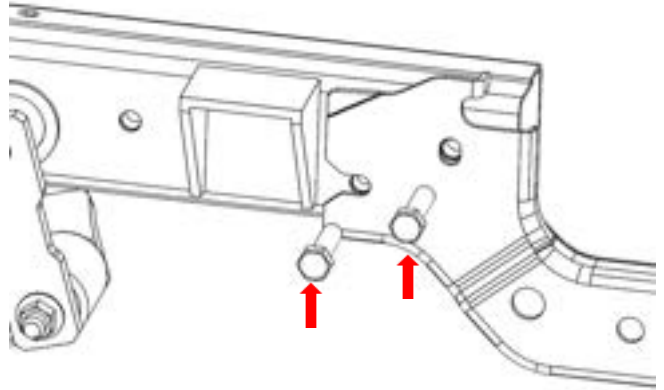

2. Fit the side arm to the chassis.  
Loosely secure with 3x bolts and 3x washers.

Repeat for the other side.

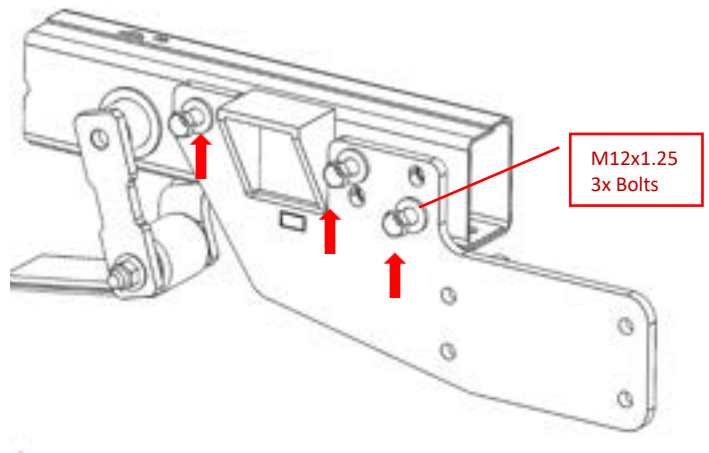

3. Slip the nut plate in the chassis.  
Loosely secure with 1x bolt and 1x washer under the chassis.

Repeat for the other side.

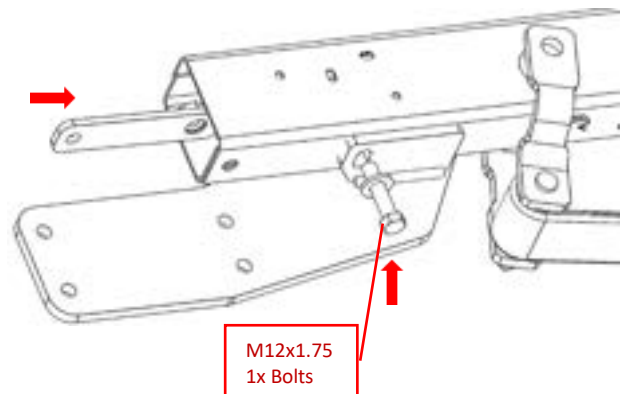

- 
4. Fit the cross tube between the side arms.  
Loosely secure the cross tube with 4x bolts, 8x washers and 4x nuts.

Repeat for the other side.

**Torque fasteners as follow**

**M12 x 1.25 = 125 Nm**

**M12 x 1.75 = 77 Nm**

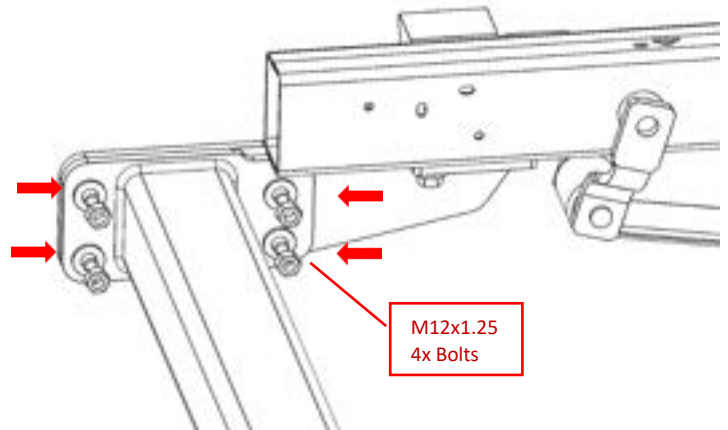

- 
5. Fit the plug bracket to the dropper and secure with 2x screws and 2x nuts.  
Insert the TBM in the hitch box as showing.

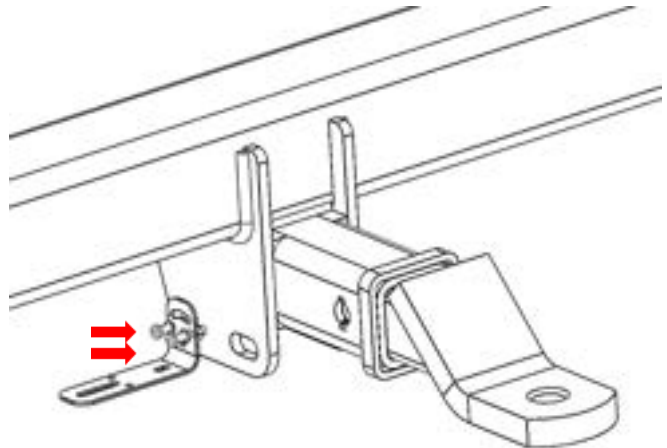

### IMPORTANT

Due to possible vehicle variations, always confirm any noted vehicle colour wires with a multi-meter to ensure the correct function is identified before soldering or scotch locking. For vehicle wires denoted with two colours (example; RED/GREEN) the first colour will always be the main wire colour while the second colour is the thinner trace colour on the wire.

6. On the LHS for the chassis locate the 8-way breakout connector and remove the blanking plug (1).
7. Plug in the trailer patch (102462-WL) into the mating vehicle.

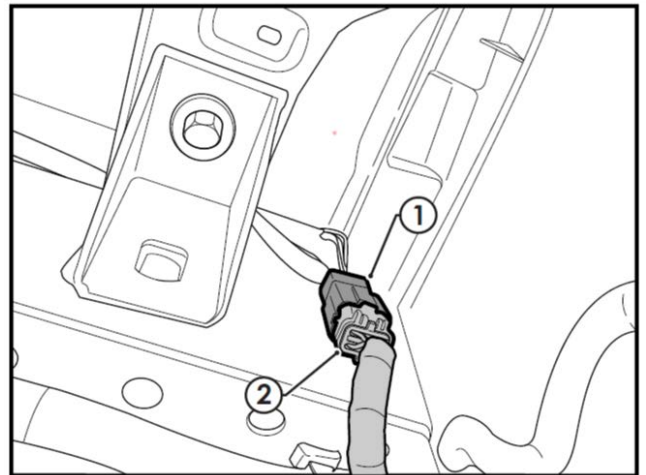

8. Connect the trailer patch 24-way connector (1) to the ECU (04835) (2).
9. Secure the ECU to the chassis using tek screws or cable tie (not supplied).

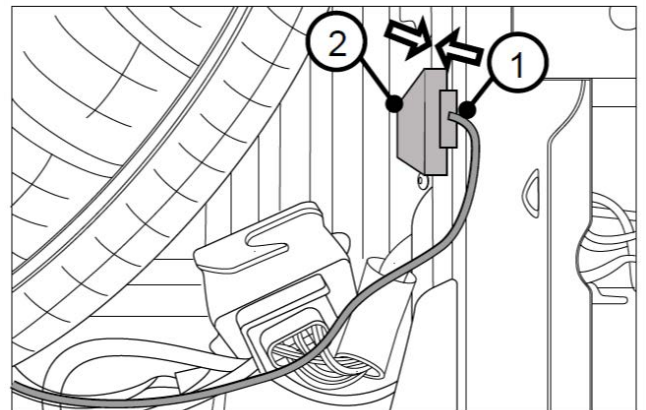

- 
10. Mount the trailer socket to the plug bracket.
  11. Route the tail harness blue connector (tail length 1200mm) towards the trailer patch mating connector.

- 
12. Connect the tail harness 8-way connector (1) to the trailer patch mating 8-way connector (2).
  13. Strip and crimp, GREY (3) and GREY/BLACK (4) wires to the RPA patch matching GREY (5) and GREY/BLACK (6) wires and insulate connections.
  14. Apply silicon grease (7) (not provided) to the blue connectors to prevent water ingress.

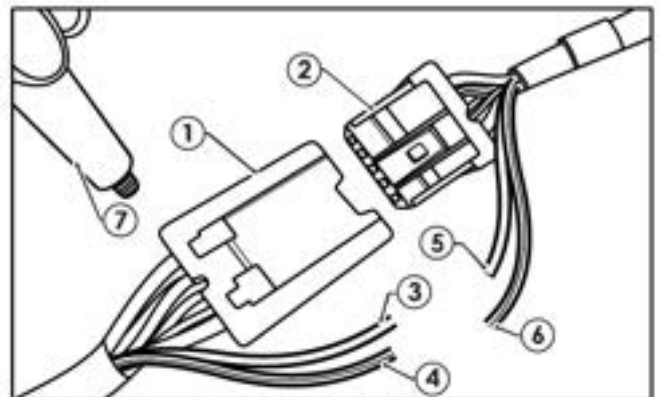

- 
15. Test the trailer patch function using a light board or multi-meter.
  16. Secure all harness using cable tie (not supplied).
  17. Place fitting instructions in glovebox after fitment.



## CUSTOMER INFORMATION

PLACE THESE INSTRUCTIONS IN THE  
VEHICLE'S GLOVEBOX AFTER INSTALLATION

**THANK YOU FOR PURCHASING TRAILBOSS. WITH CORRECT MAINTENANCE AND CARE  
THIS PRODUCT WILL PROVIDE A LIFETIME OF TROUBLE-FREE OPERATION.**

### **TOWBAR MAINTENANCE AND CARE:**

1. Trailboss recommend that the towbar LUG or TBM (Trailer Ball Mount) Pull Pin and R-clip are removed and stored when not in use. Removal of LUG or TBM (Trailer Ball Mount) is advisable when not in use to assist with any of the following.
  - Ensure rear number plate is not obscured.
  - Allow maximum available departure angle and prevent any potential interference.
  - Prevent possible interference with vehicles reverse sensors or camera detecting a tow ball mount as an obstruction during reversing.
  - Removes towball mount as an obstruction for when moving around the rear of the vehicle.
2. Trailboss recommends routine inspection of your towbar to ensure trouble free towing.
  - Bolt security and tension should be regularly inspected and checked for correct tension. Replace any worn or defective parts with suitable grade & class fasteners. Inspection should be requested to coincide with vehicle major services.
3. It is the owner's responsibility to ensure towing and down ball weight capacities of the towing vehicle are not exceeded.
  - Towing and down ball weights allowable may differ according to model variations. Please refer to owner's manual or vehicle dealer to confirm exact rating for your vehicle model variant.
  - It is not uncommon for the vehicle tow rating to differ from the towbar rating. When this occurs, the lesser rating must be adhered to.
  - For vehicles fitted with enhanced vehicle functions that may be altered/changed when towing i.e Trailer sway mitigation, blind spot detection, adaptive cruise control etc. Please consult owner's manual to understand changes enabled when towing and after towing.

### **WARRANTY INFORMATION:**

Trailboss Towbars are covered by a Lifetime Warranty.

Our goods come with guarantees that cannot be excluded under the Australian Consumer Law. You are entitled to a replacement or refund for a major failure and for compensation for any other reasonably foreseeable loss or damage. You are also entitled to have the goods repaired or replaced if the goods fail to be of acceptable quality and the failure does not amount to a major failure.

For further details please contact customer service on 1800 812 017.



## PRO SERIES SILENT ANTI-RATTLE HITCH PIN

Your Trailboss towbar is equipped with a Pro Series Silent Anti-Rattle Hitch Pin technology to help reduce towbar tongue rattle in most driving conditions. Please ensure below instructions are understood and routine maintenance is carried out to ensure best towing experience.

Regularly inspect for wear and check the tightness of the Silent Anti-Rattle Hitch Pin. Follow instructions below to re-tighten the nut as necessary when movement and noise in the tow ball mount is noted.

- Before towing, ensure R-Clip is properly installed and hitch pin nut is installed and tensioned. Replacement parts are available from your Pro Series Distributor.

## TOWBALL MOUNT REMOVAL/INSTALLATION

### STEP 1

Insert Trailer Ball Mount (TBM) (a) into towbar hitchbox (b), aligning hole in TBM shank (c) with hole in hitchbox (d) (Fig. 1)

### STEP 2

Insert Silent Anti-Rattle Hitch Pin (e) through hole in hitchbox and hole in TBM shank (g); ensure the locators are inserted into the notches in the hitchbox (Fig. 2)

### STEP 3

Screw Silent Anti-Rattle Hitch Pin Nut (f) onto Smart Pin (g); tighten Smart Pin Nut until finger tight, ensuring TBM is restrained from up and down movement.

### STEP 4

Tighten Silent Anti-Rattle Hitch Pin Nut by turning nut a further 1/8th of a turn in the clockwise direction using a 24mm spanner (Fig. 4).

### STEP 5

Install Silent Anti-Rattle Hitch Pin R-Clip through the hole that provides best clearance or easiest access. (Fig. 5)

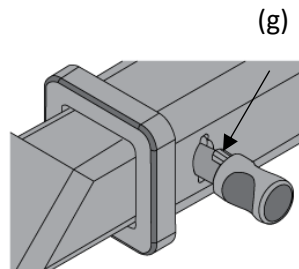
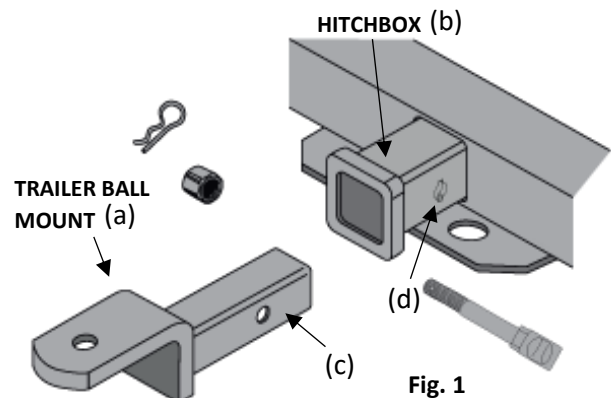

Fig. 2

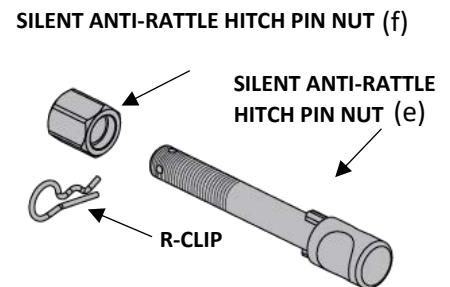

Fig. 3

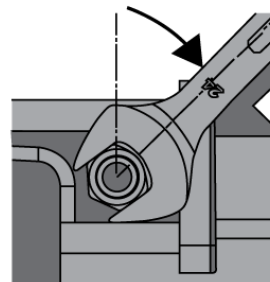

Fig. 4

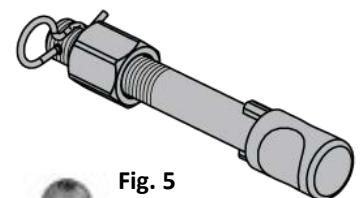

Fig. 5

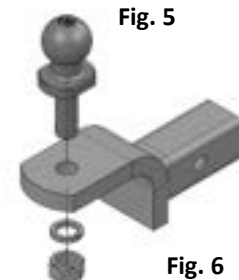

Fig. 6