



TOWBAR INSTALLATION INSTRUCTIONS

PART NUMBER QTKM23L

KIA SPORTAGE QL MY19 JAN19 CL4

PRODUCT DETAILS:

Part Number:	QTKM23L	Maximum Towing Braked:	1900	kg
ECU Number:	04826	Maximum Towing Unbraked:	750	kg
Tail Harness Length Required:	1200 mm	Maximum Static Ball Load:	100	kg
TBM/Lug Part Number:	21148			

FITTING DETAILS:

Towbar Installation Time:	60 Mins.	RPA Disable/Other:	YES
Total Installation Time:	90 Mins.		
Bumper Cut Required:	Yes		

Note:

- RPA Disable via switch on centre console.

TRAILBOSS RECOMMENDS THAT INSTRUCTIONS ARE READ AND UNDERSTOOD COMPLETELY PRIOR TO FITMENT.

BEFORE YOU START:

Check all hardware items have been included refer to assembly diagram.
Please ensure this towbar is only fitted to vehicle models as per Trailboss application guide.

Bumper Cuts

Vehicle and bumper variations can and do occur during vehicle manufacture after initial towbar design. Fitment of towbar to vehicle and accuracy of bumper cut must be assessed prior to any bumper modifications made. Incorrect bumper cuts are not covered under Trailboss warranty.

NOTE: Bumper cuts need to be approached with care, refer to notes below.

- Bumper centreline – where the centreline of the bumper needs to be determined, the installer must assess centre point by measurement of bumper width or determining two symmetrical reference points to give centreline.
- Bumper edge – To assist with accurate bumper cut measurement, reference to the start of the bumper edge is now being commonly used.
 - Measure from bottom edge along bumper and around corner to the 70 mm point (Figure 1).
 - Do not measure from visible bumper front of corner, upwards (Figure 2).

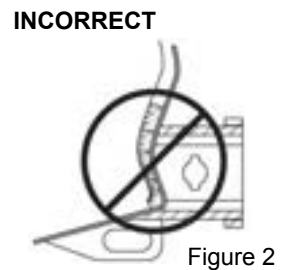
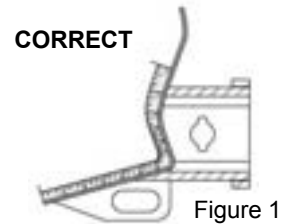

Drilling

- For any required drilling during installation, ensure that the area is clear of fuel, electrical & other components that may be damaged.
- All holes drilled into metal body panels shall have all burrs & swarf removed then coated with a suitable rust preventative paint.

Bolts/Fasteners

- Ensure that all hardware is fastened to correct torque as specified in this fitting instruction.
- All fasteners supplied with this product are used to achieve a specified clamp loading. If replacement is required ensure that fasteners of the same grade and class are used.

NOTE: Achieving correct torque is critical to proper installation and responsibility of the installer. Towbar failures attributed to tension issues from over tightening or under tightening are not covered by Trailboss warranty.

Product Labels

- a. Towbar load rating sticker provided with this product shall be conspicuously located on inside rear end of the driver's door.

WARNING:

Do not, drill, cut, weld or otherwise modify the towbar.

FOR TOWING PURPOSES ONLY - This towbar is designed and tested by Trailboss to adhere to ADR 62/02 which provides only for the expected load demands of towing.

TOWBAR ASSEMBLY DIAGRAM

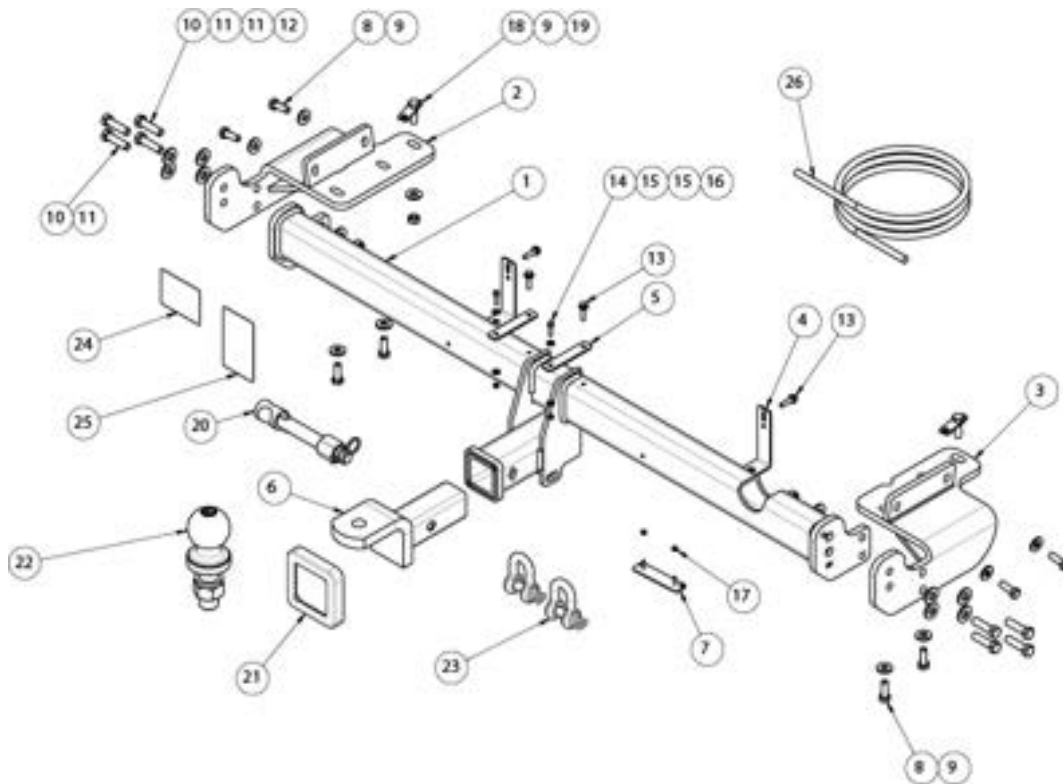

ITEM	DESCRIPTION	QTY
1	WELDED CENTRE ASSEMBLY	1
2	SIDEARM ASSY EXTENSION LH	1
3	SIDEARM EXTENSION ASSY RH	1
4	BUMPER TAB BRACKET	2
5	SMART KEY ANTENNA BRACKET	2
6	TRAILER BALL MOUNT	1
7	PLUG BRACKET	1
8	SET SCREW HEX HD M10x30x1.25P	8
9	WASHER PLAIN M10x25x3	10
10	SET SCREW HEX HD M12x45x1.25P	8
11	WASHER FLAT M12	12
12	NUT HEX HD M12x1.25P	4
13	TEK SCREW 14-20 HEX HD 22mm	4

ITEM	DESCRIPTION	QTY
14	SET SCREW HEX HD M5x20x0.8P	2
15	WASHER FLAT M6x12.5x1.2	4
16	NUT NYLOC HEX HD M5x0.8P	2
17	NUT NYLOC HEX HD M4x0.7P	2
18	T BOLT ASSEMBLY	2
19	NUT HEX HD M10x1.5P	2
20	SMART PIN SILVER	1
21	HITCH BOX COLLAR COVER	1
22	TOWBALL 50mm	1
23	"D" SHACKLE 10mm	2
24	COMPLIANCE LABEL	1
25	LOAD RATING LABEL	1
26	WIRING LOOM	1

-
1. Open tailgate and remove exposed plastic taillight trim cover.

Repeat for other side

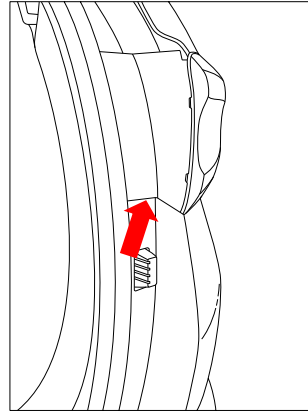

-
2. Remove exposed 2 x Screws securing the taillight to the body.

3. Remove taillight by pulling rearwards and disconnect from wiring harness.

Repeat for other side.

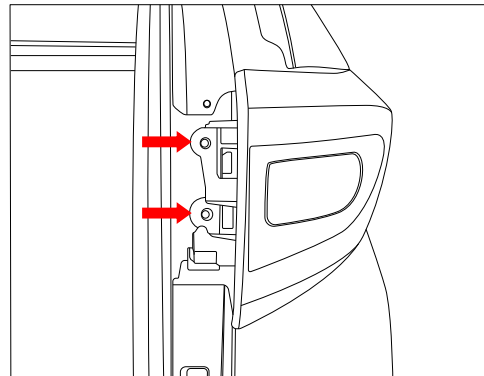

-
4. In light cavity, remove 2 x Scrivets.

Repeat for other side.

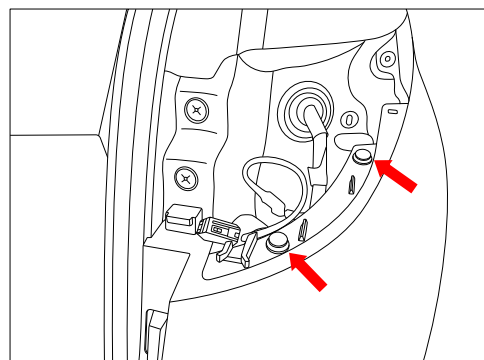

-
5. In wheel arch remove 4 x Screws along the outer edge and 1 x Scrivet located on the inside of the wheel arch.

Repeat for other side.

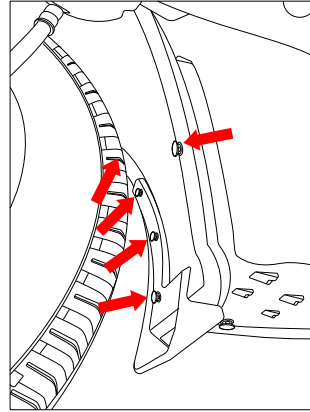

-
6. Under vehicle, remove the mudflap and underbody trim secured with 3 x scrivets.

Repeat for other side.

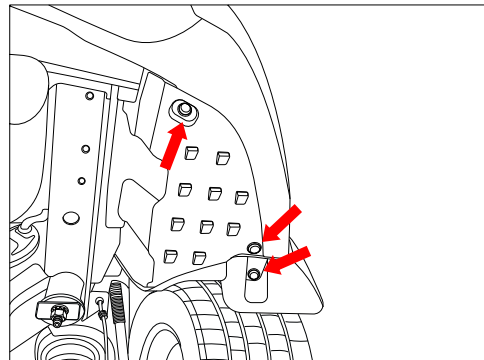

-
7. Remove 2 x bolts securing the impact beam to the rear panel, accessible from under the vehicle.

Repeat for other side.

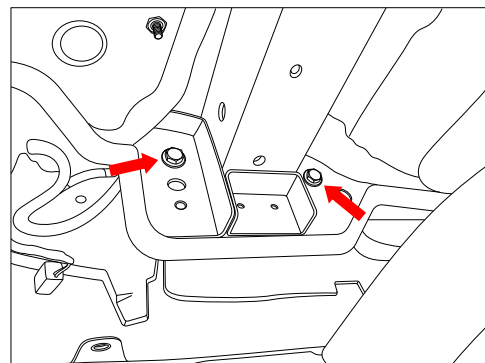

-
8. Peel away bumper from the ends and remove from vehicle along with the impact beam. Ensure to disconnect any electrical connectors

-
9. Remove the rubber seal located on the underside of the chassis rail to expose the hole.

10. Insert the T-bolt assembly into the chassis hole and position it over the hole.

Repeat for other side.

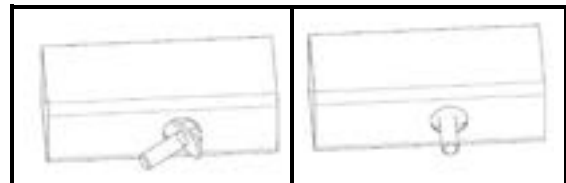
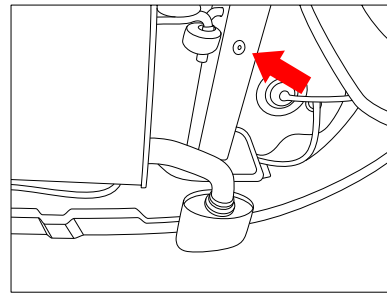

-
11. Loosely secure sidearm to underside of chassis rail using 2x M10 bolts, complete with 1x washer per bolt and 1 x M10 nut complete with 1 x washer.

Repeat for other side.

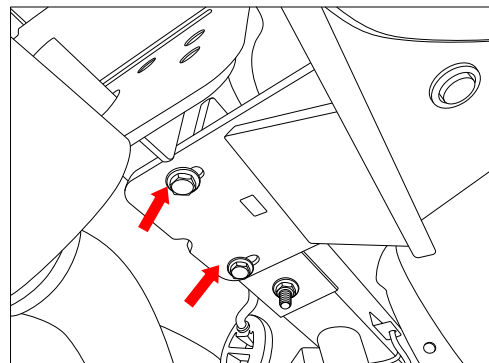

-
12. Loosely secure sidearm to side face of chassis rail using 2x M10 bolts, complete with 1x flat washer per bolt.

Repeat for other side.

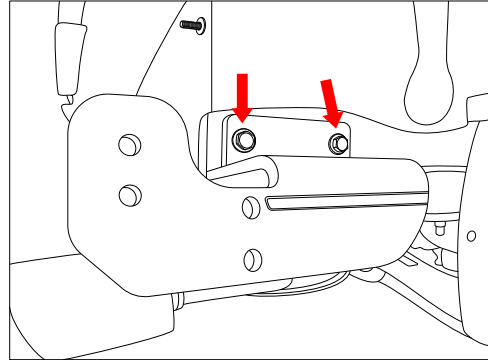

-
13. Loosely secure welded assembly to sidearms using 4 x M12 bolts per side arm, complete with 2 x flat washer and 1x M12 nut per 2 of the bolts, and 1x flat washer per the remaining 2 bolts.

Position the towbar and torque all bolts.

M10 : 48Nm

M12 : 89Nm.

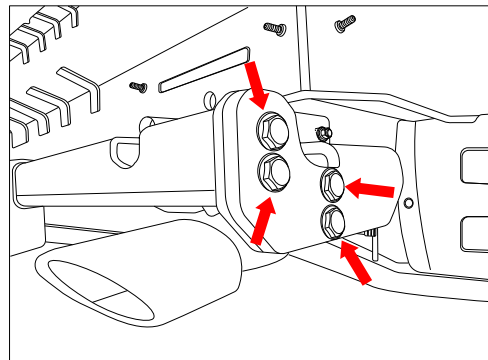

-
14. Remove 3 x Scrivets securing impact beam bumper tabs to bumper.
15. Remove 2 x clips securing top of impact beam to bumper.
16. Where applicable, release smart key antenna from impact beam.
17. Detach wiring from impact beam and remove and discard impact beam from rear bumper.

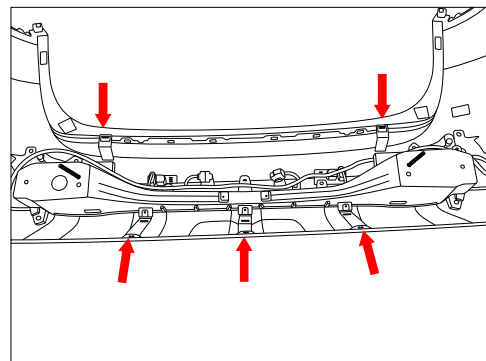

18. On outer surface of the bumper determine the centre and mark off 90mm wide and 125mm long measured from the bottom edge of the bumper.

Cut out the marked off area and deburr edges.

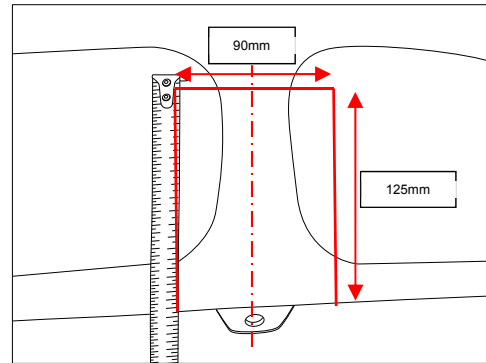

19. On the underpanel trim (removed in step 6), mark off and cut out a section 200mm from the top edge x 150mm from the side.

Repeat for the other side.

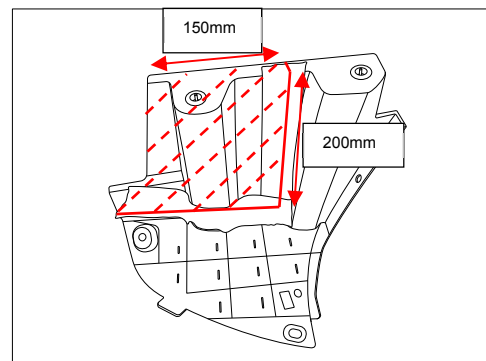

20. Where required, fit the smart key antenna brackets to the crosstube with 2 x Tek screws and secure the sensor to the mounting plates with 2 x M5 bolts complete with 2 x washes and 1 x nut per bolt.

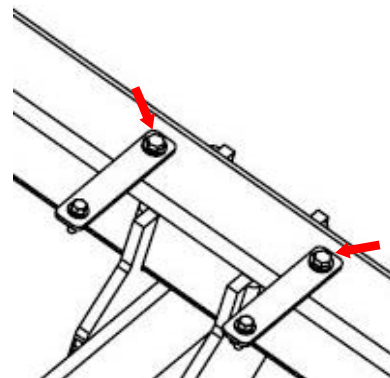

IMPORTANT

Due to possible vehicle variations, always confirm any noted vehicle colour wires with a multi-meter to ensure the correct function is identified before soldering or scotch locking. For vehicle wires denoted with two colours (example; RED/GREEN) the first colour will always be the main wire colour while the second colour is the thinner trace colour on the wire.

21. At the vehicle LHS rear quarter, remove the vent (1), grommet underneath the vent (2) and the LHS rear quarter underside grommet (3).
22. Drill out the two grommet holes (2+3) to Ø30mm.

Ensure the area being drilled into is clear of all obstructions before drilling.

File down any rough edges and apply rust inhibitor (not supplied) after drilling.

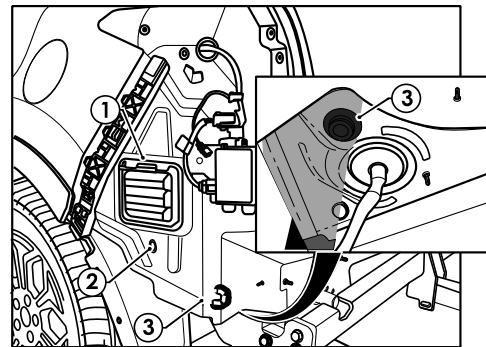

23. From inside of the vent cavity, route the trailer patch (P/No: 101469-WL) (1) out through the grommet (2) located under the vent. **Note: The ECU connector, ground ring terminal and tail harness connector stay inside the vent cavity. Refer to the trailer patch harness grommet orientation.**

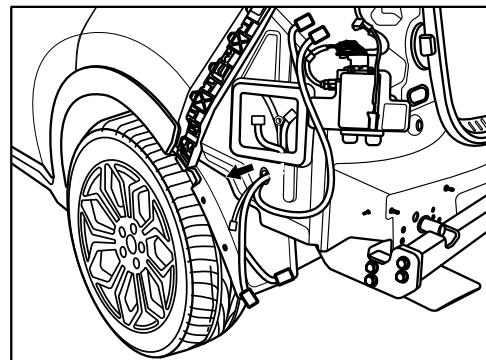

24. Inside the LHS rear quarter vent cavity, secure the trailer patch ground ring terminal (1) to the vehicle grounding point (2).

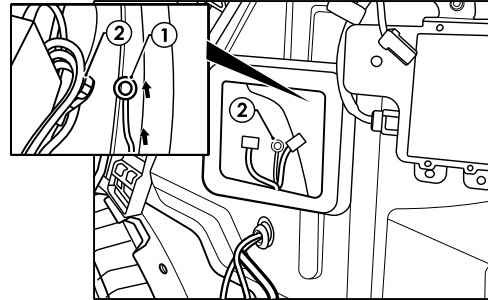

25. Connect the trailer patch connector (1) to the ECU (P/No: 04826) (2). Locate a suitable area on the sheet metal (3) where the ECU will be mounted and clean with an alcohol wipe (not supplied). Remove the backing from the back of the ECU and mount the ECU (2) onto the sheet metal area (3). **Ensure the ECU is mounted with the connector pointing downwards.**

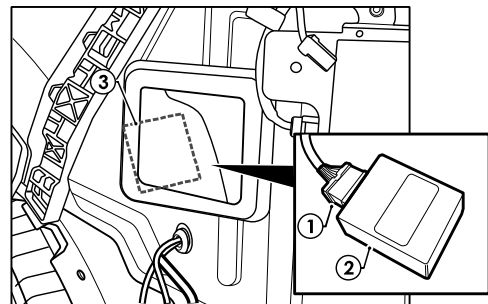

26. Connect the trailer patch connectors (1) in between the vehicle LHS 4-way connectors (2).
27. Connect the trailer patch 12-way connector (3) to the vehicle harness mating 12-way connector (4).

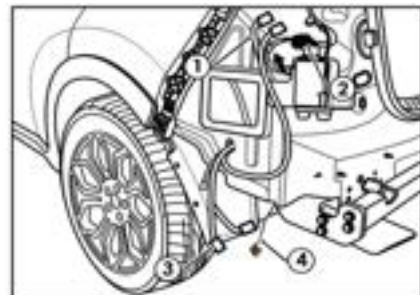

28. At the rear exterior of the vehicle, leave enough length on the tail harness so the plug can be mounted later.

29. Route the tail harness (tail length: 1200mm) (2) across the LHS and up into the drilled out hole (3). Adjust the trailer patch harness grommet so that it is seated correctly and cable tie (not supplied) in place.

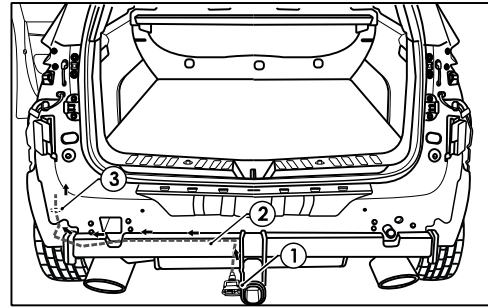

30. Connect the tail harness 8-way connector (1) to the trailer patch mating 8-way connector (2).

31. Waterproof the connectors by applying electrical grease or silicone (3) to the back of each connector.

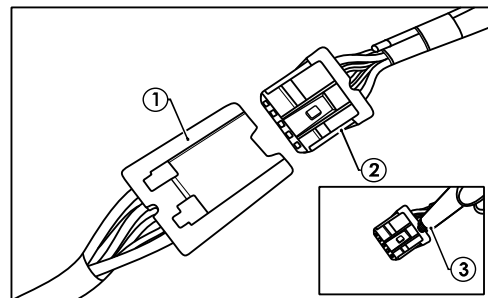

32. In the engine bay, route the power harness (P/No: 04825) (1) from the battery area and down the engine bay to the underside of the vehicle. **Do not connect the power harness ring terminal to the battery at this point.**

33. Route the power harness (1) along the LHS chassis rail towards the LHS rear quarter of the vehicle. Connect the power harness 1-way connector to the trailer patch 1-way mating connector. **Keep harness routing clear of all sharp objects, moving parts or areas of extreme heat. Secure the harness with cable ties (not supplied) after routing.**

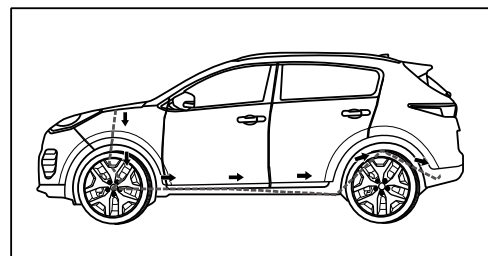

-
34. In the engine bay, secure the power harness ring terminal (1) to the battery positive terminal (2).

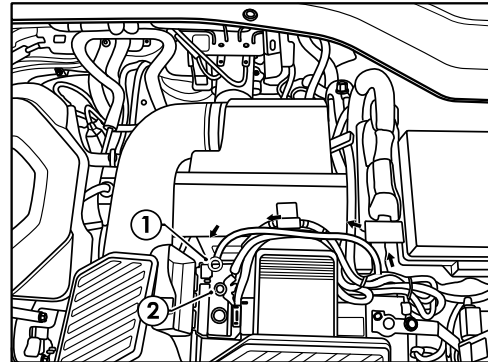

-
35. The RPA can be disabled via a switch (1) on the centre console.

36. Test the trailer patch function using a light board or multi-meter.

37. Secure all harnesses using cable ties (not supplied).

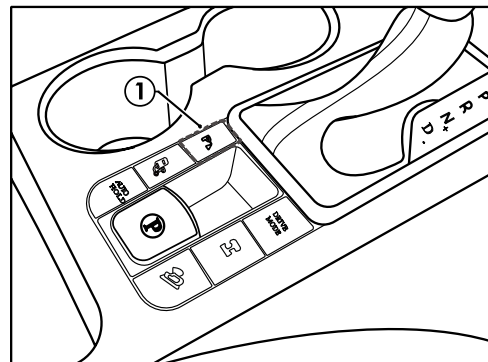

-
38. Refit rear bumper by following steps 1 to 6 and 9 in reverse order.

39. Where applicable, secure smart key antenna to smart key antenna brackets.

40. Secure loose wiring to towbar using cable ties.

41. Secure the 2 x bumper tabs to the bumper with 2 x scrivenets and secure, in position to the crosstube, with 2 x tek screws.

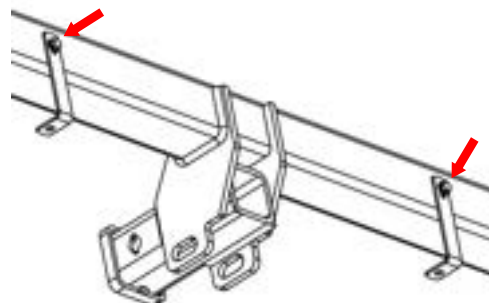

-
42. Place the fitting instruction in the glove box after fitment.
 43. Determine an appropriate position for the plug bracket. Mark out and drill 2x \varnothing 5mm holes 69mm apart on bumper skin to support plug bracket.

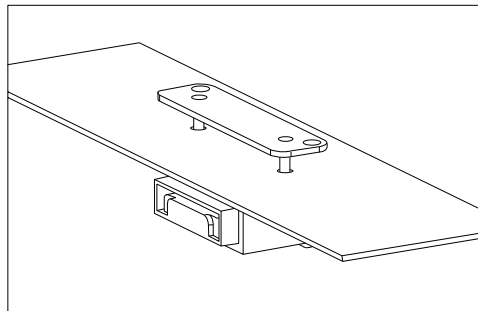



CUSTOMER INFORMATION

PLACE THESE INSTRUCTIONS IN THE
VEHICLE'S GLOVEBOX AFTER INSTALLATION

**THANK YOU FOR PURCHASING TRAILBOSS. WITH CORRECT MAINTENANCE AND CARE
THIS PRODUCT WILL PROVIDE A LIFETIME OF TROUBLE-FREE OPERATION.**

TOWBAR MAINTENANCE AND CARE:

1. Trailboss recommend that the towbar LUG or TBM (Trailer Ball Mount) Pull Pin and R-clip are removed and stored when not in use. Removal of LUG or TBM (Trailer Ball Mount) is advisable when not in use to assist with any of the following.
 - Ensure rear number plate is not obscured.
 - Allow maximum available departure angle and prevent any potential interference.
 - Prevent possible interference with vehicles reverse sensors or camera detecting a tow ball mount as an obstruction during reversing.
 - Removes towball mount as an obstruction for when moving around the rear of the vehicle.
2. Trailboss recommends routine inspection of your towbar to ensure trouble free towing.
 - Bolt security and tension should be regularly inspected and checked for correct tension. Replace any worn or defective parts with suitable grade & class fasteners. Inspection should be requested to coincide with vehicle major services.
3. It is the owner's responsibility to ensure towing and down ball weight capacities of the towing vehicle are not exceeded.
 - Towing and down ball weights allowable may differ according to model variations. Please refer to owner's manual or vehicle dealer to confirm exact rating for your vehicle model variant.
 - It is not uncommon for the vehicle tow rating to differ from the towbar rating. When this occurs, the lesser rating must be adhered to.
 - For vehicles fitted with enhanced vehicle functions that may be altered/changed when towing i.e Trailer sway mitigation, blind spot detection, adaptive cruise control etc. Please consult owner's manual to understand changes enabled when towing and after towing.

WARRANTY INFORMATION:

Trailboss Towbars are covered by a Lifetime Warranty.

Our goods come with guarantees that cannot be excluded under the Australian Consumer Law. You are entitled to a replacement or refund for a major failure and for compensation for any other reasonably foreseeable loss or damage. You are also entitled to have the goods repaired or replaced if the goods fail to be of acceptable quality and the failure does not amount to a major failure. For further details please contact customer service on 1800 812 017.

PRO SERIES SILENT ANTI-RATTLE HITCH PIN

Your Trailboss towbar is equipped with a Pro Series Silent Anti-Rattle Hitch Pin technology to help reduce towbar tongue rattle in most driving conditions. Please ensure below instructions are understood and routine maintenance is carried out to ensure best towing experience.

Regularly inspect for wear and check the tightness of the Silent Anti-Rattle Hitch Pin. Follow instructions below to re-tighten the nut as necessary when movement and noise in the tow ball mount is noted.

- Before towing, ensure R-Clip is properly installed and hitch pin nut is installed and tensioned. Replacement parts are available from your Pro Series Distributor.

TOWBALL MOUNT REMOVAL/INSTALLATION

STEP 1

Insert Trailer Ball Mount (TBM) (a) into towbar hitchbox (b), aligning hole in TBM shank (c) with hole in hitchbox (d) (Fig. 1)

STEP 2

Insert Silent Anti-Rattle Hitch Pin (e) through hole in hitchbox and hole in TBM shank (g); ensure the locators are inserted into the notches in the hitchbox (Fig. 2)

STEP 3

Screw Silent Anti-Rattle Hitch Pin Nut (f) onto Smart Pin (g); tighten Smart Pin Nut until finger tight, ensuring TBM is restrained from up and down movement.

STEP 4

Tighten Silent Anti-Rattle Hitch Pin Nut by turning nut a further 1/8th of a turn in the clockwise direction using a 24mm spanner (Fig. 4).

STEP 5

Install Silent Anti-Rattle Hitch Pin R-Clip through the hole that provides best clearance or easiest access. (Fig. 5)

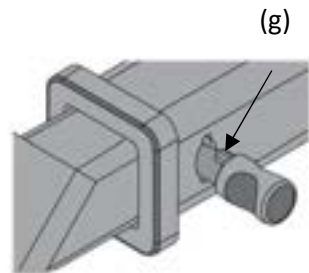
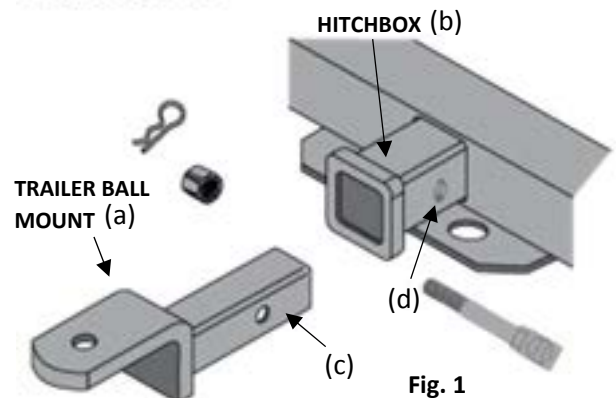

Fig. 2

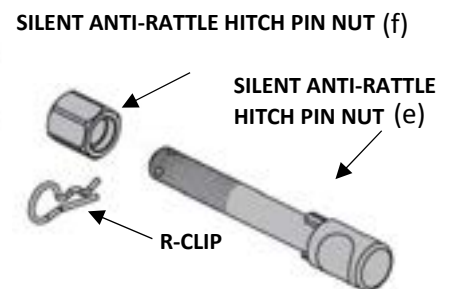

Fig. 3

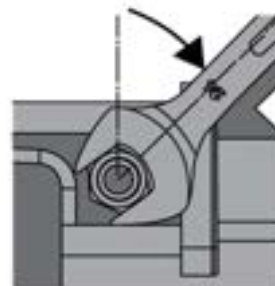

Fig. 4

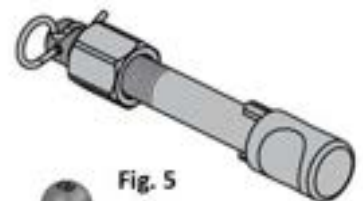

Fig. 5

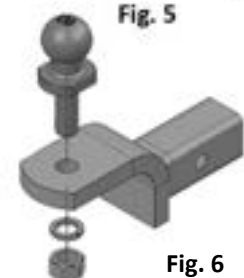

Fig. 6