

**PRODUCT DETAILS:**

---

<b>Part Number:</b>	<a href="#">QTKM25L</a>	<b>Maximum Towing Braked:</b>	<a href="#">1250</a>	kg
<b>ECU Number:</b>	<a href="#">04826</a>	<b>Maximum Towing Unbraked:</b>	<a href="#">600</a>	kg
<b>Tail Harness Length Required:</b>	<a href="#">See Note</a>	<b>Maximum Static Ball Load:</b>	<a href="#">130</a>	kg
<b>TBM/Lug Part Number:</b>	<a href="#">21232</a>			

---

**FITTING DETAILS:**

---

<b>Towbar Installation Time:</b>	<a href="#">60 Mins.</a>	<b>RPA Disable/Other:</b>	YES
<b>Total Installation Time:</b>	<a href="#">120 Mins.</a>		
<b>Bumper Cut Required:</b>	Yes		

---

**Note:**

- RPA disable use 04936
- Tail Length 1200mm

### TRAILBOSS RECOMMENDS THAT INSTRUCTIONS ARE READ AND UNDERSTOOD COMPLETELY PRIOR TO FITMENT.

#### BEFORE YOU START:

Check all hardware items have been included refer to assembly diagram.  
Please ensure this towbar is only fitted to vehicle models as per Trailboss application guide.

#### Bumper Cuts

Vehicle and bumper variations can and do occur during vehicle manufacture after initial towbar design. Fitment of towbar to vehicle and accuracy of bumper cut must be assessed prior to any bumper modifications made. Incorrect bumper cuts are not covered under Trailboss warranty.

**NOTE: Bumper cuts need to be approached with care, refer to notes below.**

- Bumper centreline – where the centreline of the bumper needs to be determined, the installer must assess centre point by measurement of bumper width or determining two symmetrical reference points to give centreline.
- Bumper edge – To assist with accurate bumper cut measurement, reference to the start of the bumper edge is now being commonly used.
  - Measure from bottom edge along bumper and around corner to the 70 mm point (Figure 1).
  - Do not measure from visible bumper front of corner, upwards (Figure 2).

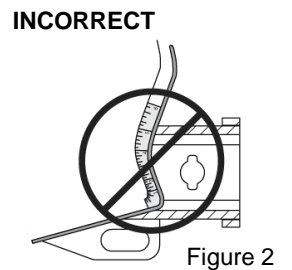
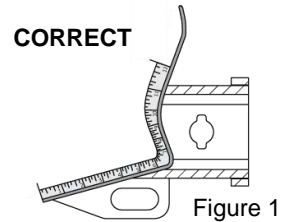

#### Drilling

- For any required drilling during installation, ensure that the area is clear of fuel, electrical & other components that may be damaged.
- All holes drilled into metal body panels shall have all burrs & swarf removed then coated with a suitable rust preventative paint.

#### Bolts/Fasteners

- Ensure that all hardware is fastened to correct torque as specified in this fitting instruction.
- All fasteners supplied with this product are used to achieve a specified clamp loading. If replacement is required ensure that fasteners of the same grade and class are used.

**NOTE: Achieving correct torque is critical to proper installation and responsibility of the installer. Towbar failures attributed to tension issues from over tightening or under tightening are not covered by Trailboss warranty.**

#### Product Labels

- a. Towbar load rating sticker provided with this product shall be conspicuously located on inside rear end of the driver's door.

#### WARNING:

**Do not, drill, cut, weld or otherwise modify the towbar.**

**FOR TOWING PURPOSES ONLY - This towbar is designed and tested by Trailboss to adhere to ADR 62/02 which provides only for the expected load demands of towing.**

### **i** TOWBAR ASSEMBLY DIAGRAM

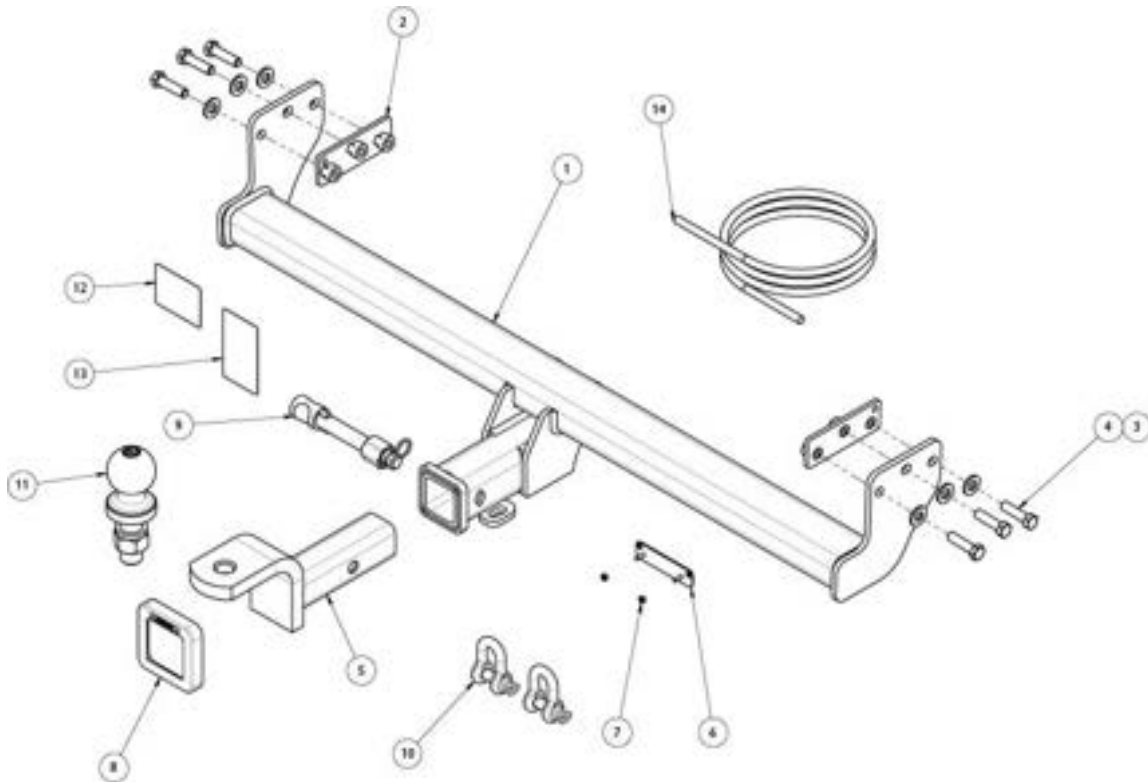

ITEM	DESCRIPTION	QTY
1	KIA SELTOS WELDED ASSY.	1
2	NUT PLATE ASSEMBLY	2
3	WASHER PLAIN 1/2"	6
4	SET SCREW HEX HD M12x45x1.25P	6
5	TRAIL BALL MOUNT	1
6	PLUG BRACKET	1
7	NUT NYLOC HEX HD M4x0.7P	2
8	HITCH BOX COLLAR COVER	1
9	SMART PIN SILVER	1
10	"D" SHACKLE 10mm	2
11	TOWBALL 50mm	1
12	COMPLIANCE LABEL	1
13	LOAD RATING LABEL	1
14	WIRING LOOM	1

1. Open tailgate to expose the taillight mounting screws. Remove 2 x screws

Repeat for other side.

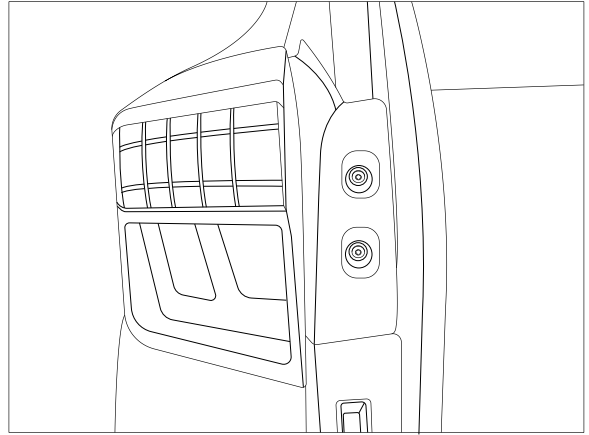

2. Remove taillight (pull rearwards) from vehicle ensuring to disconnect from wiring harness.
3. Remove 2 x exposed scrivets from the taillight cavity.

Repeat steps 2 and 3 for the other side.

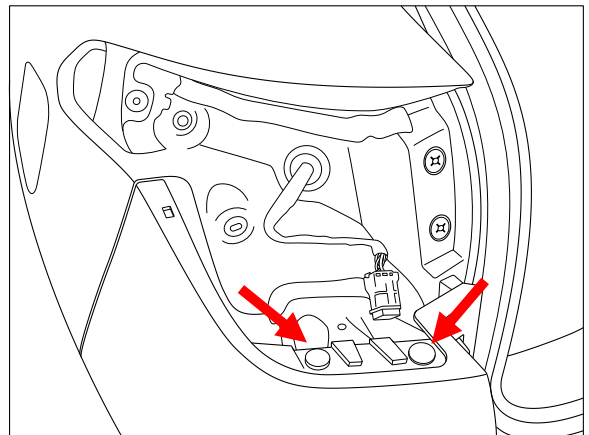

4. In wheel arch, remove 3 x screws, and 1 x scrivet from under the wheel arch.

Repeat for other side.

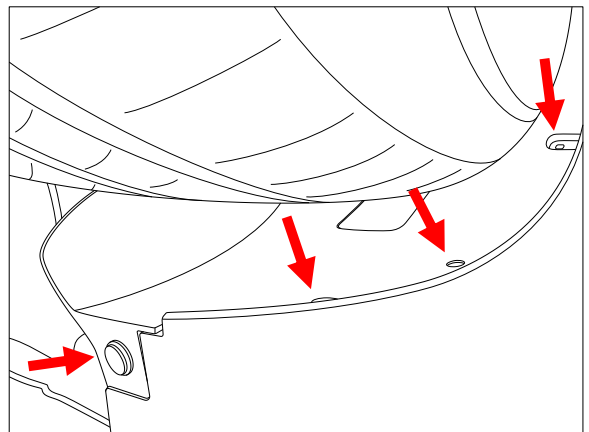

- 
5. Under vehicle on the RH side, remove and discard the plastic cover secured with 2 x scrivenets and 1 x nut.

Repeat for other side.

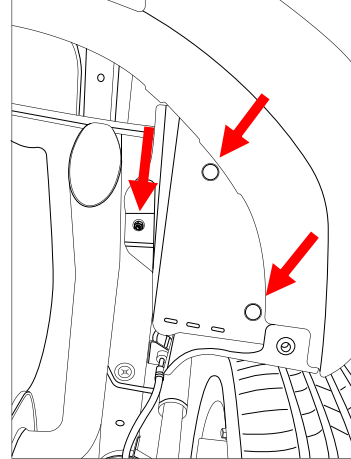

- 
6. Remove 2 x bolts securing the impact beam to vehicle.

Repeat for other side.

7. Disconnect wiring loom connector located on LH side.

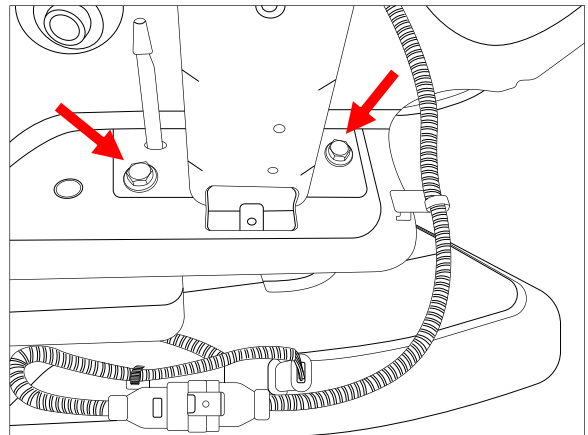

- 
8. Peel away bumper from sides and remove from vehicle ensuring to unclip any other electrical connectors.

9. Insert nut plate into the chassis rail ensuring the nuts align with the chassis holes.

Repeat step 9 for the other side.

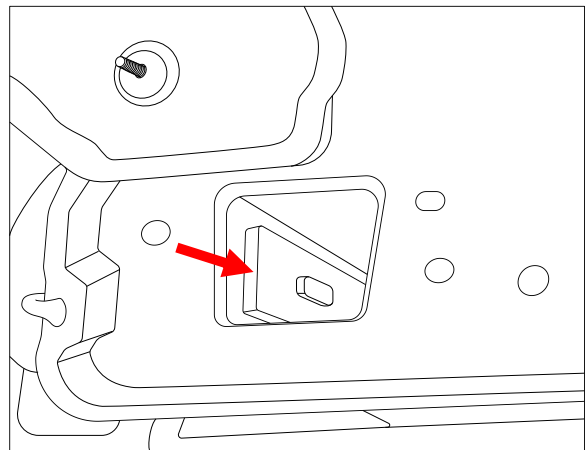

- 
10. Using 2 people, lift the crosstube into position and secure each side arm, using the nut plates inserted in step 9, with 3 x M12 bolts complete with 1 x washer per bolt.

**Tighten all fasteners to 125Nm**

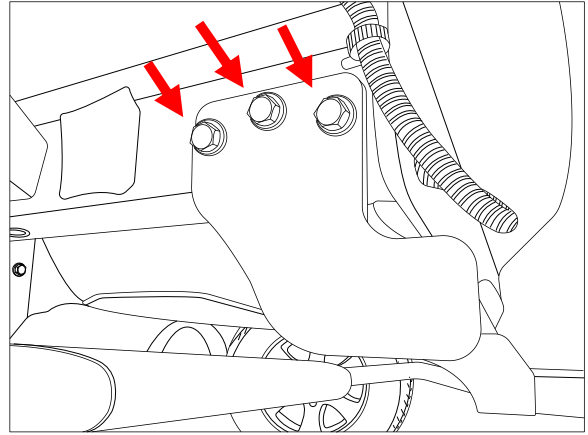

- 
11. For bumper cut determine the centre of the towbar, measure, mark off and cut out a section 75mm wide and 75mm long, measured from the bottom edge of the bumper. (Only the bottom panels are cut and not the painted section).

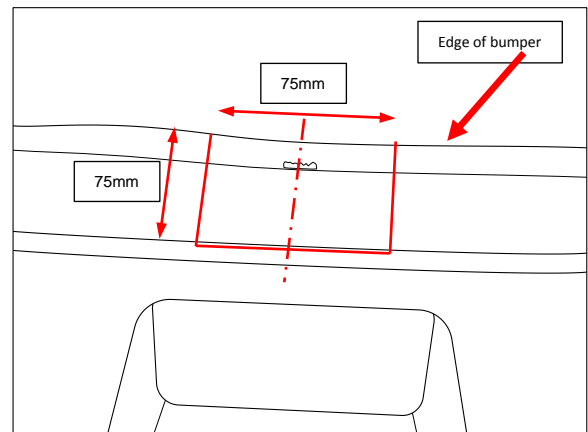

- 
12. At an appropriate position on the bumper, mark out and drill 2x ø5mm holes 69mm apart on bumper skin to support plug bracket.

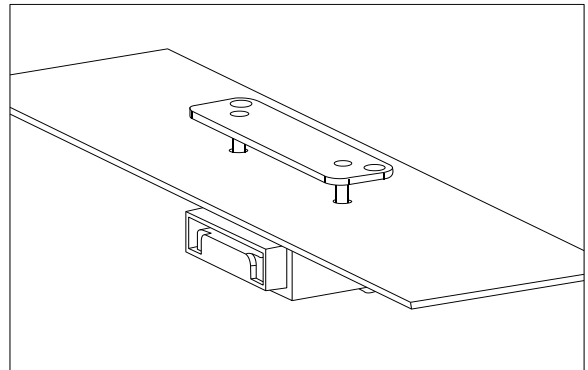

### IMPORTANT

Due to possible vehicle variations, always confirm any noted vehicle colour wires with a multi-meter to ensure the correct function is identified before soldering or scotch locking. For vehicle wires denoted with two colours (example; RED/GREEN) the first colour will always be the main wire colour while the second colour is the thinner trace colour on the wire.

13. In the Engine Bay, disconnect the vehicle battery negative terminal.
14. In the luggage compartment, remove the floor cover (1).
15. Remove the 2 trim clips securing the rear scuff trim (2).
16. Dislodge and remove the rear scuff trim (2).

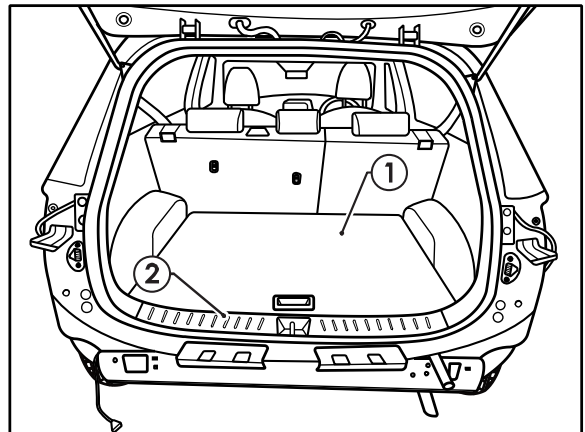

17. Remove the foam tool tray (1) and spare wheel (2).
18. Remove the bolt (3) located at the front of the luggage compartment, securing the rear seat base.
19. From the passenger compartment, remove the rear seat base by first disconnecting all seatbelt warning wiring.

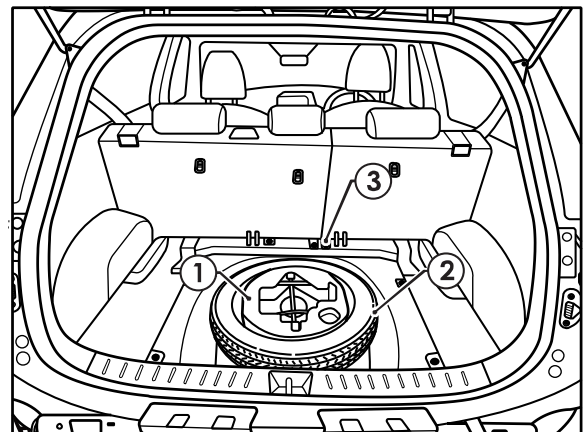

20. Fold the rear seats (1) down.
21. Remove the bolt (2) securing the RHS seat back.
22. Remove the trim (3) covering the RHS rear seat hinge.
23. Remove the RHS rear seat (1).

**Note: Only remove components and seat for RHS.**

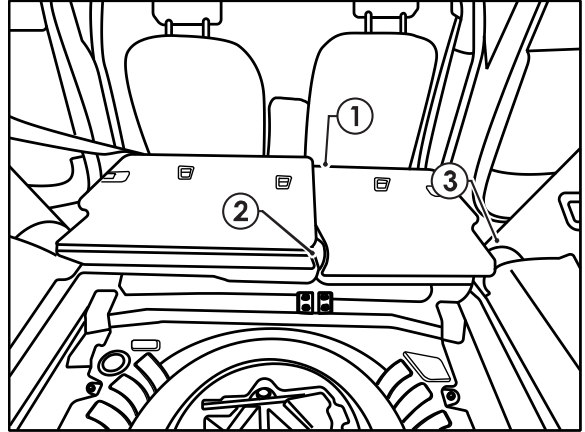

24. Remove the RHS rear passenger weather seal (1).
25. Remove the two scuff trim pieces (2).

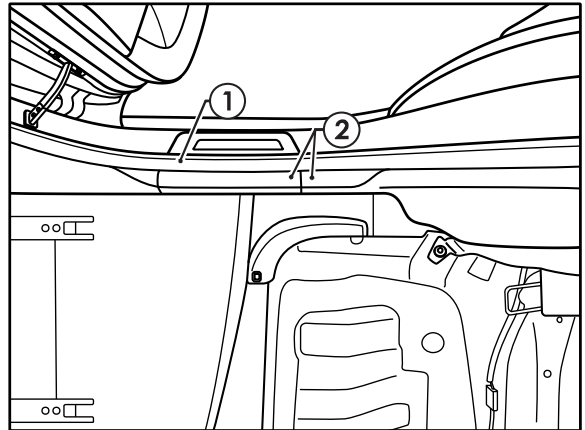

26. On the RHS, remove the four screws (1) securing the luggage compartment trim (2).
27. Remove the bolt (3) securing the seatbelt.
28. Remove the LHS luggage compartment trim.

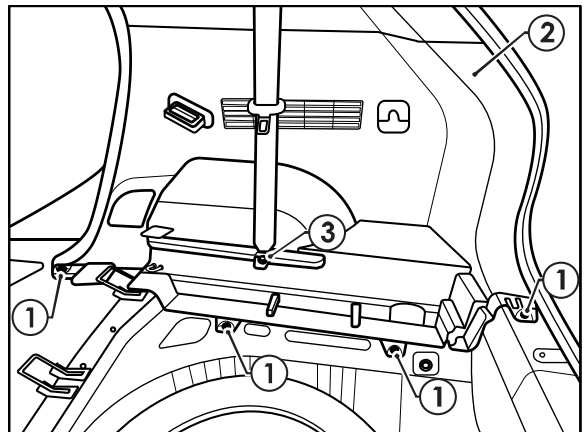



29. At the RHS tail lamp, connect the 'RHS' tail lamp connectors on the patch harness (102439-WL) (1) in between the vehicle tail light wiring and the vehicle body wiring.

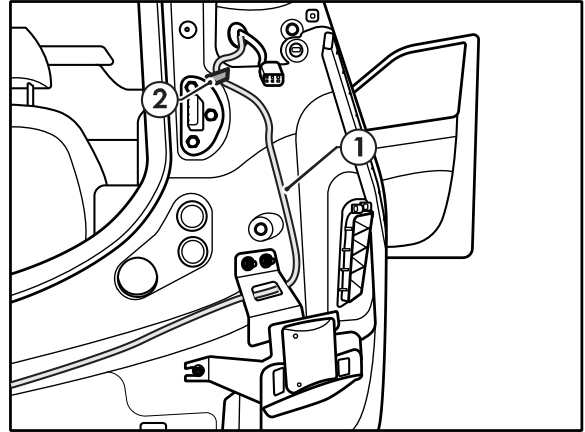

30. Unseat the vehicle harness grommet and push the existing grommet and trailer patch into the vehicle all the way until the grommet on the patch harness (2) is seated into the tail light wiring hole.

31. Route the long 'LHS' branch of the patch harness (1) outside the vehicle towards the LHS tail light (2).

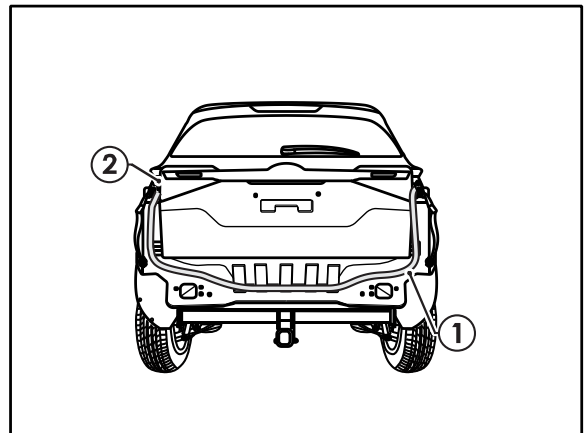

32. At the LHS tail lamp, patch in the 'LHS' tail lamp connectors between the vehicle tail light wiring and the vehicle body wiring (3).

33. Inside the vehicle, retrieve the trailer patch harness and route towards the front of the vehicle.

34. Secure the ring terminal (1) to the vehicle earthing point on the vehicle chassis (2).

35. Using an alcohol wipe, clean the RHS inner sheet metal area (3) and the underside of the ECU (04826) (4).

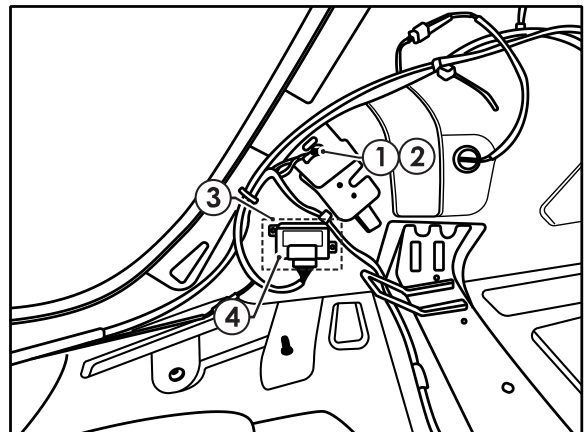

36. Connect the trailer patch 12-way connector (1) to the ECU (2).

37. Apply double sided tape to the ECU (2) and secure it to the vehicle sheet metal.

**Note: Mount the ECU, ensuring the connector is orientated downwards.**

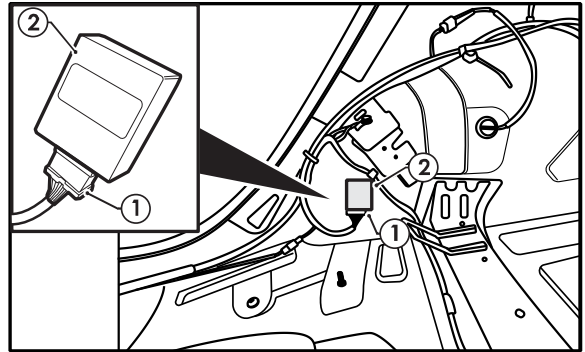

38. Continue routing the orange power wire (1) down the RHS towards the vehicle fuse panel near the driver's right knee.

39. Tuck the power wire (1) under the trim as required.

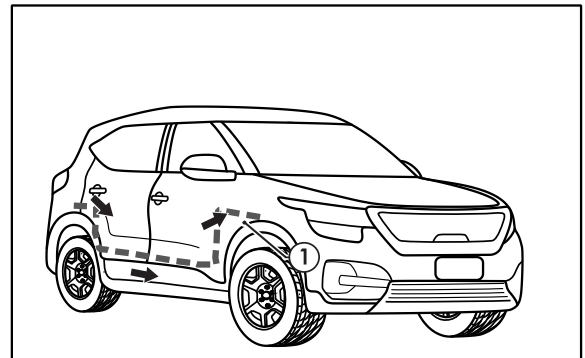

40. On the vehicle fuse box, remove the vehicle 30A fuse (1).

41. On the Add-A-Fuse (2), insert the supplied 20A fuse (3) into the Add-A-Fuse (2) top slot and then insert the vehicle 30A fuse (1) into the bottom slot.

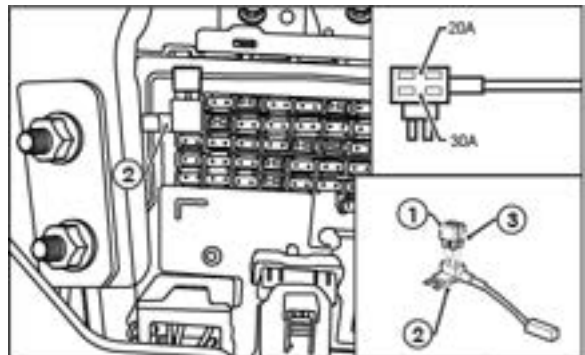

42. In the orientation shown, insert the Add-A-Fuse (1) into the slot where the previously removed fuse was located.
43. Connect the Add-A-Fuse (1) to the main harness (2).

**Note: To maintain correct electrical operation, ensure you insert the fuse adaptor into the allocated slot and in the orientation shown.**

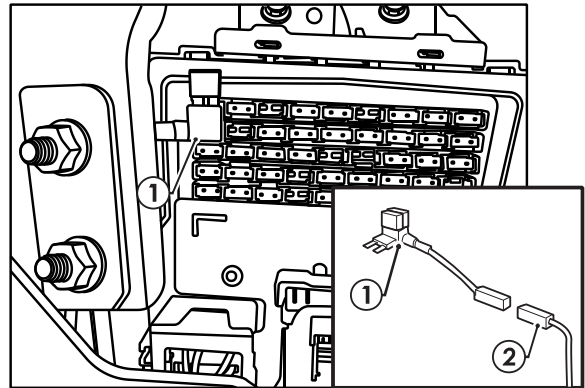

44. With the rear bumper removed, secure tail harness (tail length 1200mm) to towbar.
45. For RPA disable, patch in the supplied T Patch (1) in between the vehicle wiring and the bumper connector.
46. Route tail harness and RPA disable patch wires (2) up towards the blue connector on the patch loom.

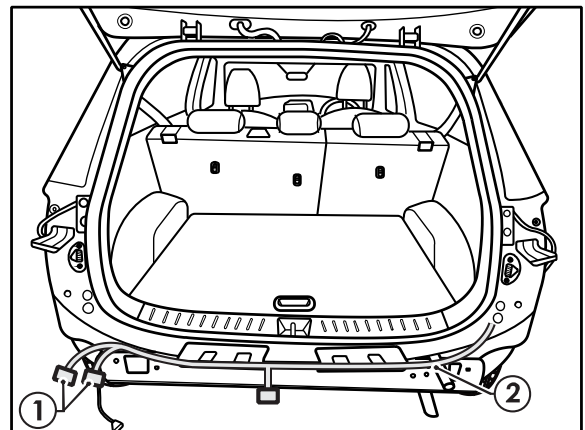

47. At the rear of the vehicle RHS, connect the tail harness (tail length 1200mm) 8-way connector (1) to the trailer patch mating 8-way connector (2).
48. Cut-off, crimp the tail harness GREY and GREY/BLACK wires (3) to the trailer patch matching GREY and GREY/BLACK wires (4).
49. Use silicone grease (5) to seal the blue connectors.

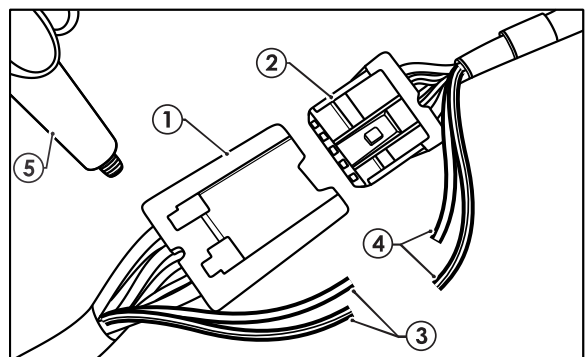

- 
50. Test the trailer patch function using a light board or multi-meter.
  51. Secure all harness using cable ties (not supplied).
  52. Re-fit all removed parts and secure all fasteners, ensuring there are no squeaks or rattles.
  53. Place the fitting instructions in the glove box after fitment.
-



## CUSTOMER INFORMATION

PLACE THESE INSTRUCTIONS IN THE VEHICLE'S GLOVEBOX AFTER INSTALLATION

**THANK YOU FOR PURCHASING TRAILBOSS. WITH CORRECT MAINTENANCE AND CARE THIS PRODUCT WILL PROVIDE A LIFETIME OF TROUBLE-FREE OPERATION.**

### TOWBAR MAINTENANCE AND CARE:

- Trailboss recommend that the towbar LUG or TBM (Trailer Ball Mount) Pull Pin and R-clip are removed and stored when not in use. Removal of LUG or TBM (Trailer Ball Mount) is advisable when not in use to assist with any of the following.
  - Ensure rear number plate is not obscured.
  - Allow maximum available departure angle and prevent any potential interference.
  - Prevent possible interference with vehicles reverse sensors or camera detecting a tow ball mount as an obstruction during reversing.
  - Removes towball mount as an obstruction for when moving around the rear of the vehicle.
- Trailboss recommends routine inspection of your towbar to ensure trouble free towing.
  - Bolt security and tension should be regularly inspected and checked for correct tension. Replace any worn or defective parts with suitable grade & class fasteners. Inspection should be requested to coincide with vehicle major services.
- It is the owner's responsibility to ensure towing and down ball weight capacities of the towing vehicle are not exceeded.
  - Towing and down ball weights allowable may differ according to model variations. Please refer to owner's manual or vehicle dealer to confirm exact rating for your vehicle model variant.
  - It is not uncommon for the vehicle tow rating to differ from the towbar rating. When this occurs, the lesser rating must be adhered to.
  - For vehicles fitted with enhanced vehicle functions that may be altered/changed when towing i.e Trailer sway mitigation, blind spot detection, adaptive cruise control etc. Please consult owner's manual to understand changes enabled when towing and after towing.

### WARRANTY INFORMATION:

Trailboss Towbars are covered by a Lifetime Warranty.

Our goods come with guarantees that cannot be excluded under the Australian Consumer Law. You are entitled to a replacement or refund for a major failure and for compensation for any other reasonably foreseeable loss or damage. You are also entitled to have the goods repaired or replaced if the goods fail to be of acceptable quality and the failure does not amount to a major failure. For further details please contact customer service on 1800 812 017.

## PRO SERIES SILENT ANTI-RATTLE HITCH PIN

Your Trailboss towbar is equipped with a Pro Series Silent Anti-Rattle Hitch Pin technology to help reduce towbar tongue rattle in most driving conditions. Please ensure below instructions are understood and routine maintenance is carried out to ensure best towing experience.

Regularly inspect for wear and check the tightness of the Silent Anti-Rattle Hitch Pin. Follow instructions below to re-tighten the nut as necessary when movement and noise in the tow ball mount is noted.

- Before towing, ensure R-Clip is properly installed and hitch pin nut is installed and tensioned. Replacement parts are available from your Pro Series Distributor.

## TOWBALL MOUNT REMOVAL/INSTALLATION

### STEP 1

Insert Trailer Ball Mount (TBM) (a) into towbar hitchbox (b), aligning hole in TBM shank (c) with hole in hitchbox (d) (Fig. 1)

### STEP 2

Insert Silent Anti-Rattle Hitch Pin (e) through hole in hitchbox and hole in TBM shank (g); ensure the locators are inserted into the notches in the hitchbox (Fig. 2)

### STEP 3

Screw Silent Anti-Rattle Hitch Pin Nut (f) onto Smart Pin (g); tighten Smart Pin Nut until finger tight, ensuring TBM is restrained from up and down movement.

### STEP 4

Tighten Silent Anti-Rattle Hitch Pin Nut by turning nut a further 1/8th of a turn in the clockwise direction using a 24mm spanner (Fig. 4).

### STEP 5

Install Silent Anti-Rattle Hitch Pin R-Clip through the hole that provides best clearance or easiest access. (Fig. 5)

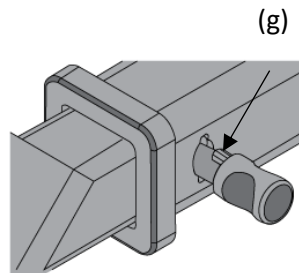
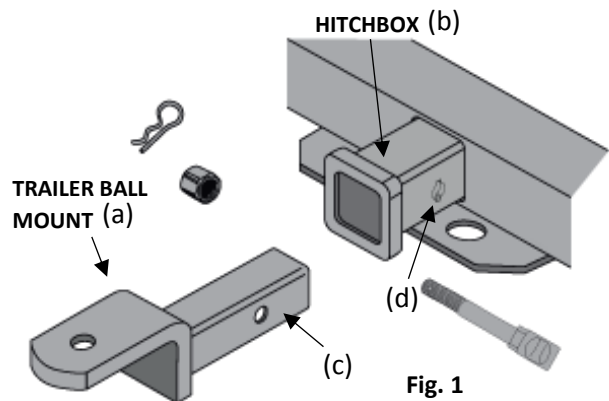

Fig. 2

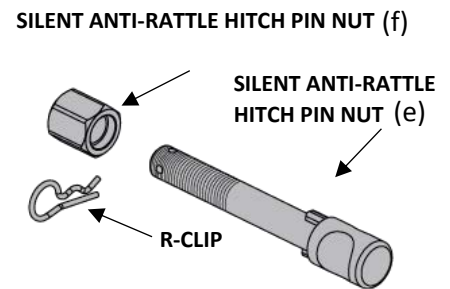

Fig. 3

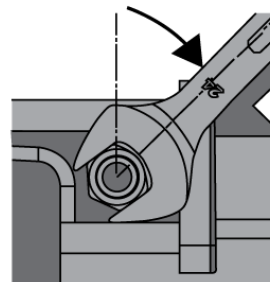

Fig. 4

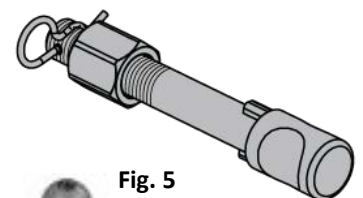

Fig. 5

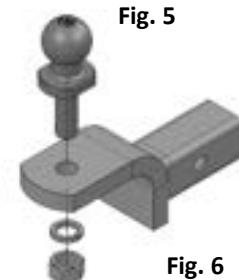

Fig. 6