

### PRODUCT DETAILS:

Part Number:	QTKM31L	Maximum Towing Braked:	1300	kg
ECU Number:	04836	Maximum Towing Unbraked:	750	kg
Tail Harness Length Required:	1200 mm	Maximum Static Ball Load:	130	kg
TBM/Lug Part Number:	21407			

### FITTING DETAILS:

Towbar Installation Time:	120 Mins.	RPA Disable/Other:	YES
Total Installation Time:	180 Mins.		
Bumper Cut Required:	Yes		

#### Note:

- RPA Disable Via switch near gear shift.



Electrical vehicles include a high voltage battery, which can lead to property damage and personal injury if handled incorrectly.

DO NOT unplug any orange high voltage cables unless the vehicles have been properly isolated by a high voltage trained technician. Series injury or death may occur.

### TRAILBOSS RECOMMENDS THAT INSTRUCTIONS ARE READ AND UNDERSTOOD COMPLETELY PRIOR TO FITMENT.

#### BEFORE YOU START:

Check all hardware items have been included refer to assembly diagram.  
Please ensure this towbar is only fitted to vehicle models as per Trailboss application guide.

#### Bumper Cuts

Vehicle and bumper variations can and do occur during vehicle manufacture after initial towbar design. Fitment of towbar to vehicle and accuracy of bumper cut must be assessed prior to any bumper modifications made. Incorrect bumper cuts are not covered under Trailboss warranty.

**NOTE: Bumper cuts need to be approached with care, refer to notes below.**

- Bumper centreline – where the centreline of the bumper needs to be determined, the installer must assess centre point by measurement of bumper width or determining two symmetrical reference points to give centreline.
- Bumper edge – To assist with accurate bumper cut measurement, reference to the start of the bumper edge is now being commonly used.
  - Measure from bottom edge along bumper and around corner to the 70 mm point (Figure 1).
  - Do not measure from visible bumper front of corner, upwards (Figure 2).

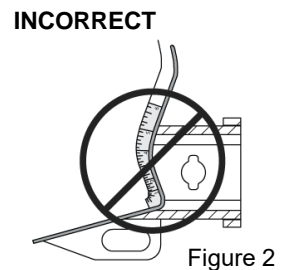
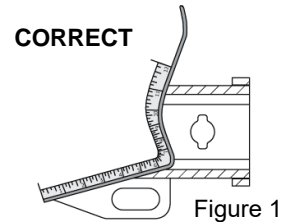

#### Drilling

- For any required drilling during installation, ensure that the area is clear of fuel, electrical & other components that may be damaged.
- All holes drilled into metal body panels shall have all burrs & swarf removed then coated with a suitable rust preventative paint.

#### Bolts/Fasteners

- Ensure that all hardware is fastened to correct torque as specified in this fitting instruction.
- All fasteners supplied with this product are used to achieve a specified clamp loading. If replacement is required ensure that fasteners of the same grade and class are used.

**NOTE: Achieving correct torque is critical to proper installation and responsibility of the installer. Towbar failures attributed to tension issues from over tightening or under tightening are not covered by Trailboss warranty.**

#### Product Labels

- a. Towbar load rating sticker provided with this product shall be conspicuously located on inside rear end of the driver's door.

#### WARNING:

**Do not, drill, cut, weld or otherwise modify the towbar.**

**FOR TOWING PURPOSES ONLY - This towbar is designed and tested by Trailboss to adhere to ADR 62/02 which provides only for the expected load demands of towing.**

### **i** TOWBAR ASSEMBLY DIAGRAM

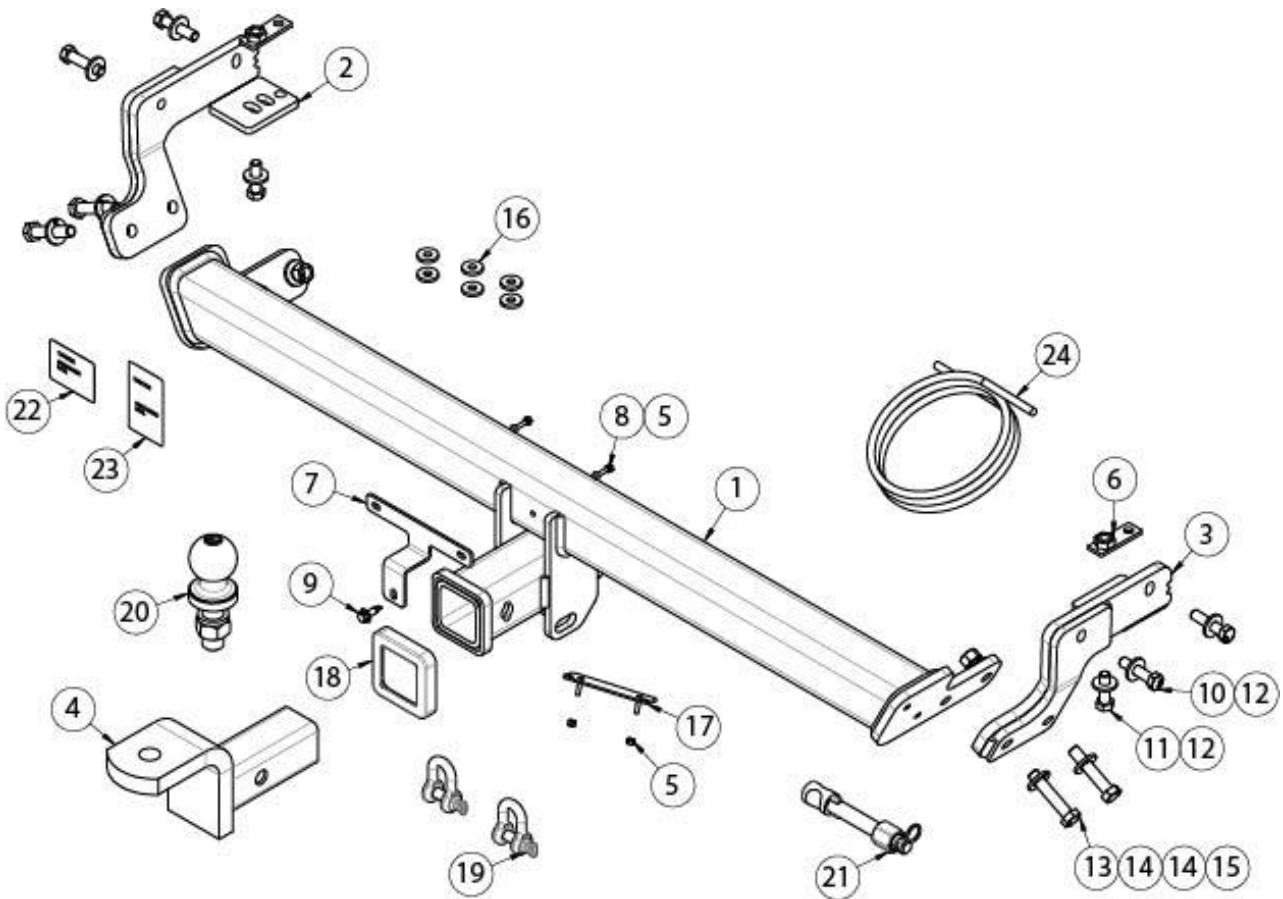

ITEM	DESCRIPTION	QTY
1	KIA NIRO WELDED ASSEMBLY	1
2	SIDE ARM – LHS	1
3	SIDE ARM – RHS	1
4	TRAILER BALL MOUNT	1
5	NUT NYLOC HEX HD M4x0.7P	4
6	NUT PLATE	2
7	SENSOR BRACKET	1
8	SCREW PAN HD M4x16x0.7P	2
9	TEK SCREW 14-20 HEX HD 22mm	1
10	SET SCREW HEX HD M10x45x1.25P	4
11	BOLT HEX HD M10x35x1.5P	2
12	WASHER PLAIN M10x25x3mm	6

ITEM	DESCRIPTION	QTY
13	BOLT HEX HD M12x60x1.25P	4
14	WASHER PLAIN M12x27x3mm	8
15	NUT HEX HD M12x1.75P	4
16	WASHER PLAIN M8x22x3	6
17	PLUG BRACKET	1
18	HITCH BOX COLLAR COVER	1
19	"D" SHACKLE 10mm	2
20	TOWBALL 50mm	1
21	SMART PIN SILVER	1
22	COMPLIANCE LABEL	1
23	LOAD RATING LABEL	1
24	WIRE LOOM	1

1. Disconnect the connector (1) in the engine compartment to shut the 12V power off.
2. In the fuse box, pull the yellow tag (2) to dislodge the main fuse.

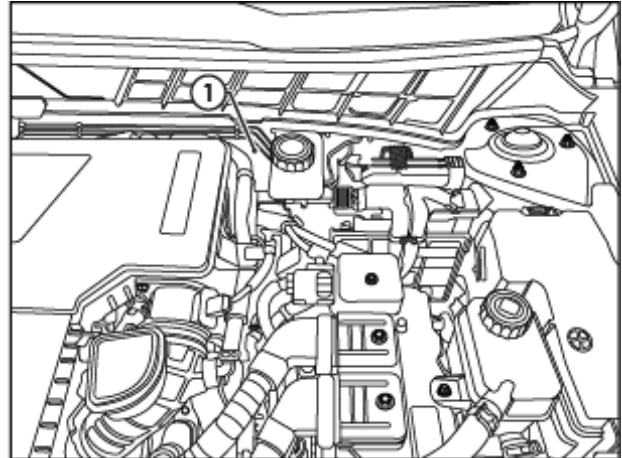
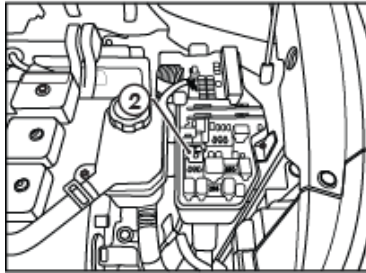

3. Open the tailgate.  
Remove the 2x screws.  
  
Repeat for the other side.

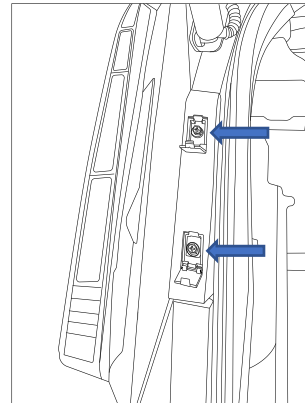

4. Remove the taillight access cover.  
Remove 1x nut from the rear of taillight.  
  
Carefully pull the taillight outboard from the vehicle.  
  
Repeat for the side.

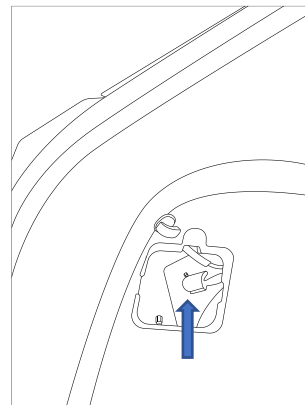

- 
5. Remove 1x scrivet clip on the bumper.

Repeat for the other side.

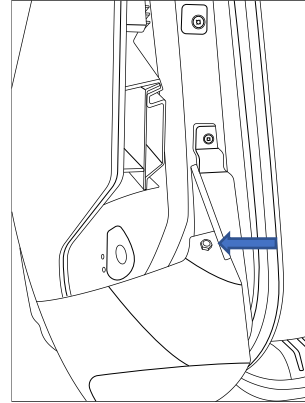

- 
6. Remove 2x screws and 1x scrivet clip inside the wheel arch lining.

Repeat for the other side.

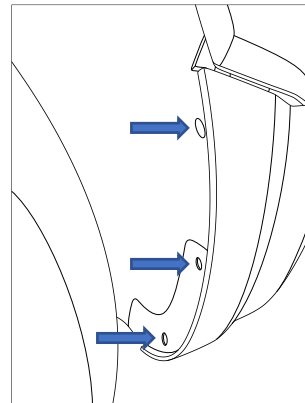

- 
7. Peel back the wheel arch lining and unclip the wheel fender.

Repeat for the other side.

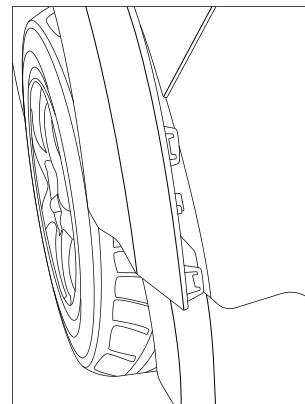

- 
8. Remove 4x scrivet clip under the bumper.

Repeat for the other side.

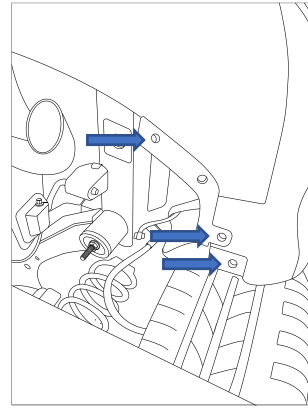

- 
9. Remove 2x bolts behind the bumper.

Repeat for the other side.

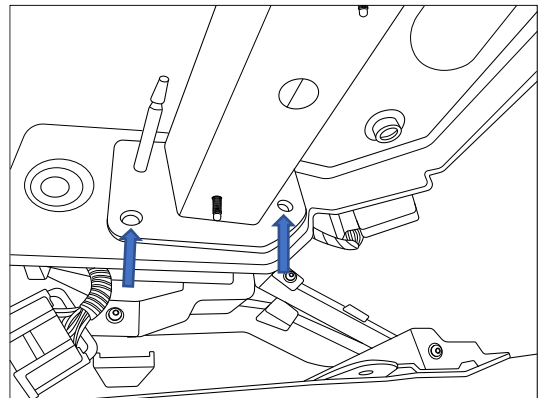

- 
10. Unclip the bumper and disconnect the bumper wire harness.

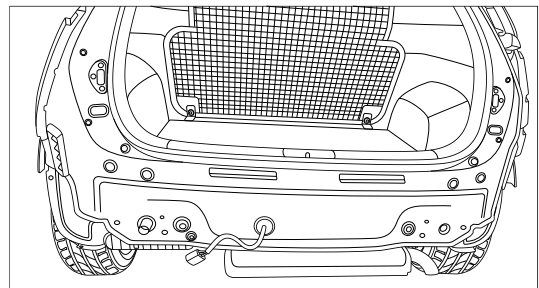

- 
11. Remove 2x nuts and pull the cannister away from the vehicle.

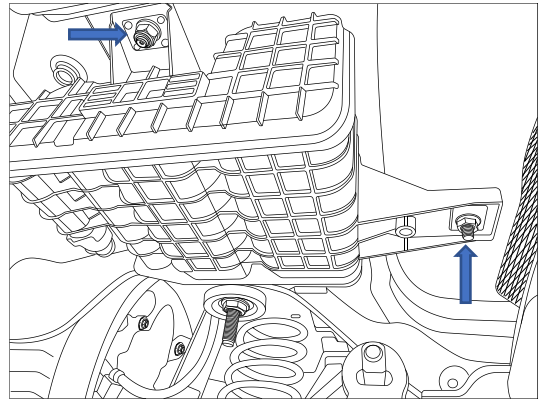

- 
12. Feed the nut plate inside the chassis hole.

Repeat for the side.

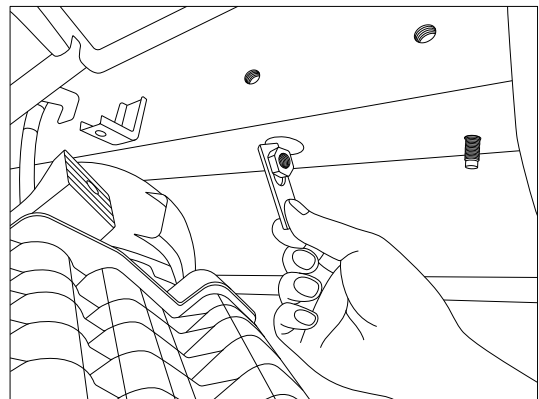

- 
13. Place the side arm to the chassis.  
Loosely secure with a M10x1.5 and a M10 washers to the underside of the chassis  
Loosely secure with (2x) M10x1.25 and (2x) M10 washers to the side of the chassis.

Repeat for the other side.

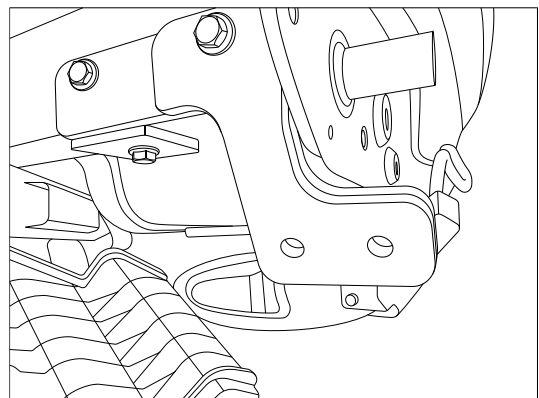

14. Place the cross tube between the side arms.  
Loosely secure with 2x M12, 4x M12 washers  
and 2x M12 nuts.

Repeat for the other side.

**Torque fasteners as follows:**

M10 x 1.25p = 48 Nm

M12 x 1.75P = 77 Nm

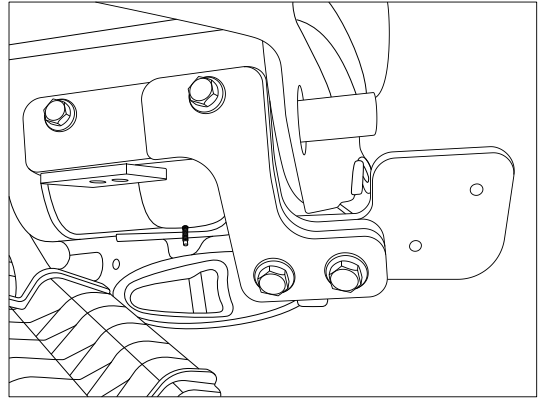

15. Remove 5x scrivets clips and 2x screw on the  
sensor from the impact beam.  
Remove the wire harness impact beam.  
Discard the impact.

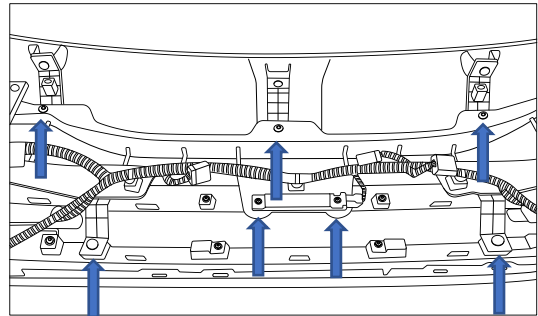

16. Locate centre line of bumper. Place masking  
tape on the bumper outer skin  
Mark and cut out an area, (90mm x 130mm),  
to clear the hitch box.  
Be mindful to remove any wiring in the cut out  
area.

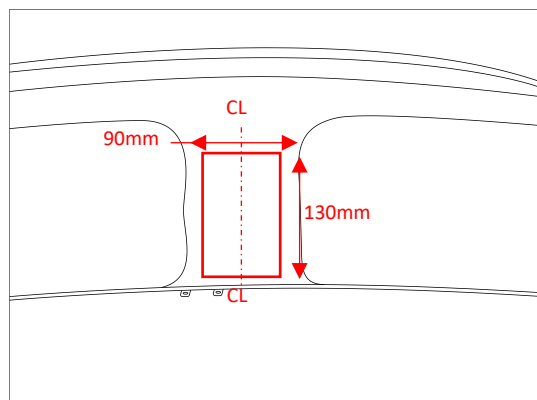



17. Place the sensor bracket to the tow and secure with a tek screw.  
Place the bumper close vehicle.  
Secure the antenna to the bracket using 2x screws and 2x nuts.

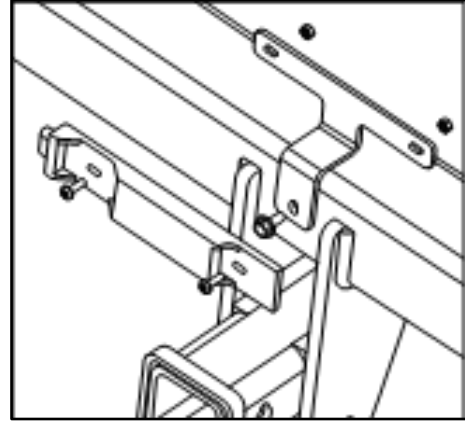

18. Locate the plug bracket and ensure the harness cable length is long enough.  
Drill 2x  $\varnothing$ 5mm holes 69mm apart  
Remove all swarf and rough edges

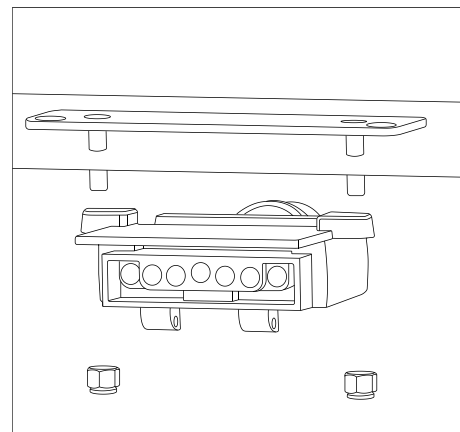

19. Place 2x washers between the cannister and the vehicle at each mounting mount to offset the cannister away from the vehicle.

**Note:**

This will clear the cannister from the bolt head under the side arm.

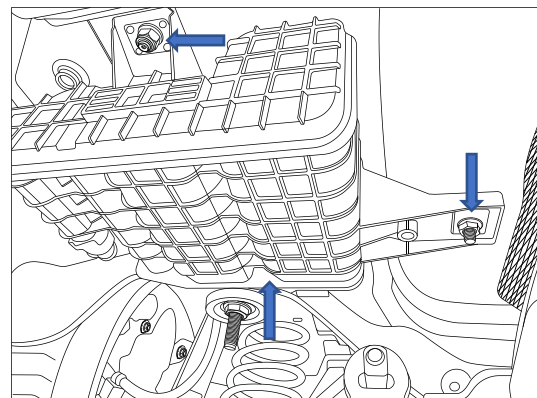

- 
20. In the rear cargo area, remove the luggage compartment floor (1).
  21. Remove the cargo blind (2).
  22. Remove Rear Scuff Trim (3).

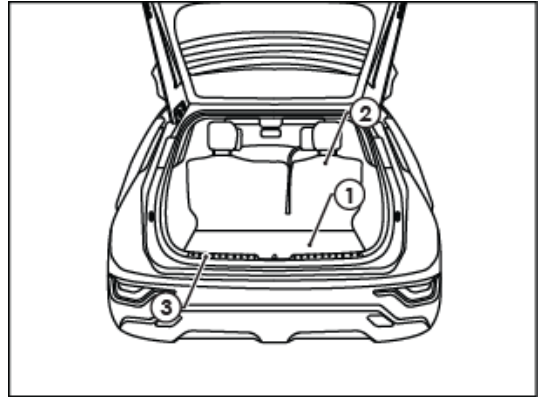

- 
23. Remove the rear seat base and if present, disconnect the connectors underneath the rear seat base.

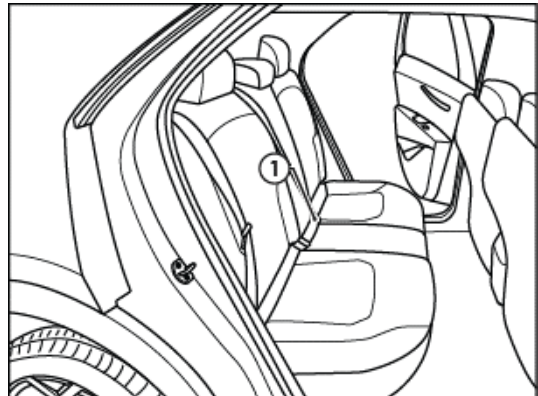

- 
24. Drop down the LHR seat and remove 2x seat retaining bolts (1).

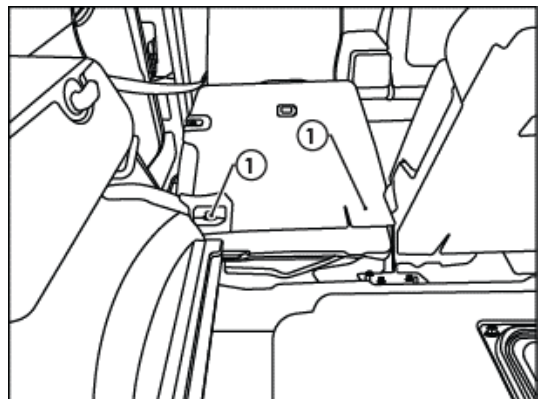

25. At the LHS rear door, dislodge the aperture seal (1).
26. Remove Phillips head screw (2).
27. Remove the LHS Door Still Trim (3) by carefully pulling in an upward direction.

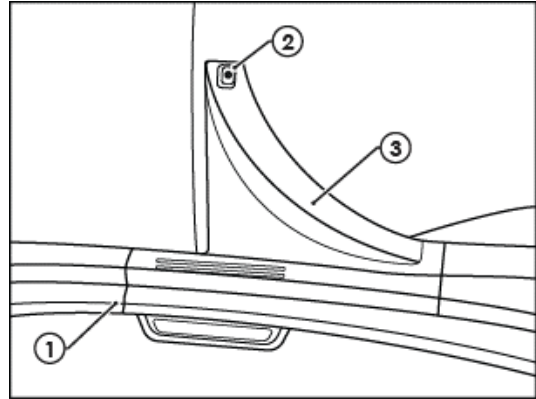

28. Remove the Rear Top Pillar Trim (1) on the LHS luggage compartment area.
29. Remove the 3x Philips head screws (2) on LHS lower luggage compartment trim.
30. Dislodge the LHS luggage compartment trim (3) and if present, disconnect the connectors from behind and remove the LHS Luggage Compartment Trim.
31. Repeat for RHS.

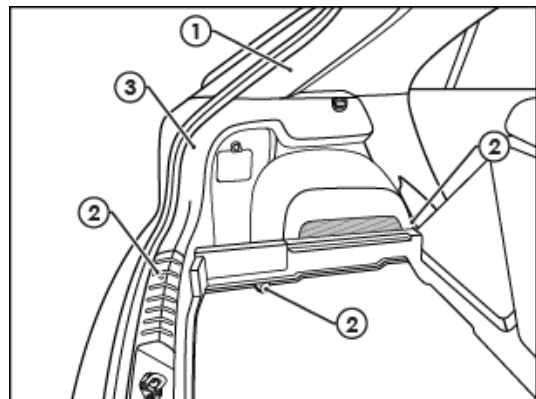

32. Behind the LHS rear panel, remove the tape securing the 6-way Trailer Pre-wire connector (1) from vehicle harness.
33. Connect the Trailer Wiring Harness 6-way Pre-Wire connector to the vehicle 6-way pre-wire connector (1).
34. Patch the Trailer Wiring Harness 3-way connectors between the vehicle LHS Taillight Connector (2).

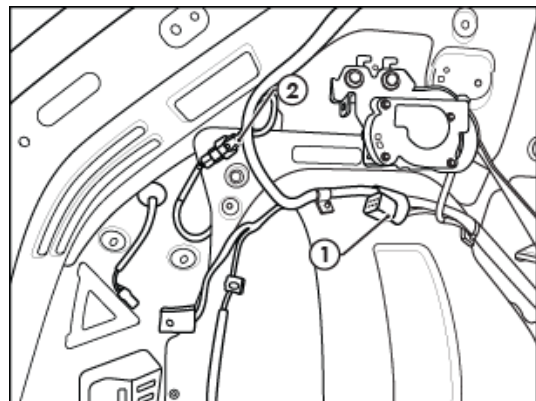

35. Route the earth branch of Trailer Wiring Harness towards the vehicle ground located at the RHR of the luggage compartment trim.
36. Secure the Trailer Wiring Harness Ground Terminal to the vehicle ground (1).

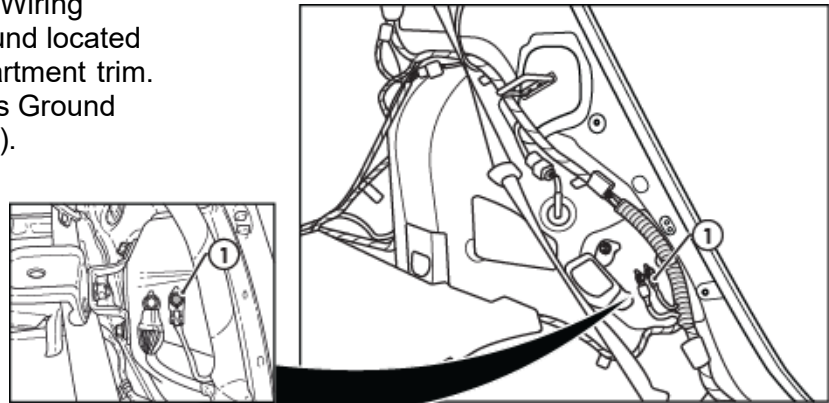

37. In the rear LHS compartment area, locate the side wall on LHS wheel arch.
38. Using the supplied Cleaning Pad, clean the back of the Trailer ECU and the flat surface on the vehicle where Trailer ECU would be mounted.
39. Peel off the backing from the supplied double sided tape and adhere to the Trailer ECU.
40. Adhere the Trailer ECU onto the flat surface as shown (1).
41. Connect the Trailer ECU connector (2) to the Trailer ECU (3) of 5.

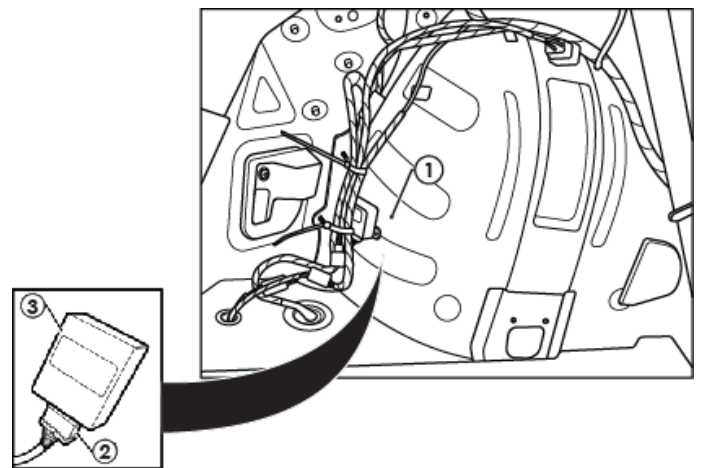

**Note: Ensure the connector is orientated downwards.**

42. With the rear bumper removed, connect the Exterior Trailer Wiring Harness 6-way patch connector to the vehicle 6-way RH and LH taillight connector (1).
43. Connect the tail harness (tail length 400mm) 8-way connector (1) to the trailer patch mating 8-way connector (2). (Refer to last section image)
44. Water proof the connector using electric grease or silicon.
45. Mount the trailer plug to plug bracket.

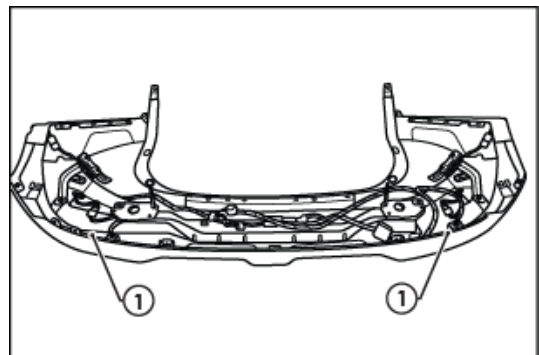

46. Remove the grommet from the rear LHS of vehicle compartment area (1).
47. Loosely attach the Rear Bumper Fascia to the vehicle while routing the External Trailer Wiring Harness via the grommet.
48. Connect the 2x 6-way connector from External Trailer Wiring Harness to the Internal Trailer Wiring Harness (2).

**Important**



Ensure the grommet is seated correctly and makes a good seal.

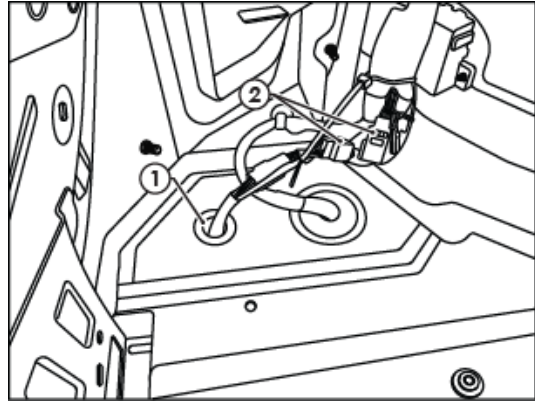

49. Secure all harness using supplied cable ties.
50. Test the trailer patch function using a light board or multi-meter.
51. Re-fit all removed parts and secure all fasteners, ensuring there are no squeaks or rattles.
52. The RPA function can be disabled via a switch next to the gear shifter.
53. Place the fitting instructions in the glove box after fitment.

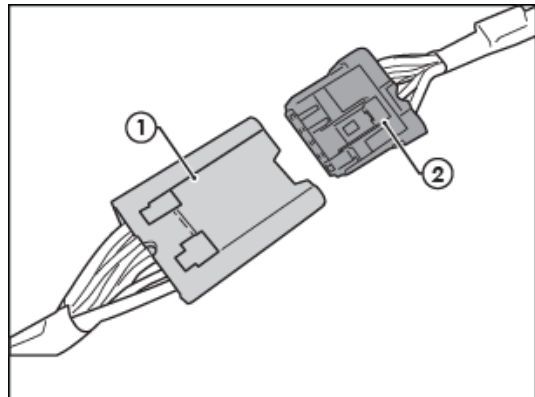



## CUSTOMER INFORMATION

PLACE THESE INSTRUCTIONS IN THE  
VEHICLE'S GLOVEBOX AFTER INSTALLATION

**THANK YOU FOR PURCHASING TRAILBOSS. WITH CORRECT MAINTENANCE AND CARE  
THIS PRODUCT WILL PROVIDE A LIFETIME OF TROUBLE-FREE OPERATION.**

### **TOWBAR MAINTENANCE AND CARE:**

1. Trailboss recommend that the towbar LUG or TBM (Trailer Ball Mount) Pull Pin and R-clip are removed and stored when not in use. Removal of LUG or TBM (Trailer Ball Mount) is advisable when not in use to assist with any of the following.
  - Ensure rear number plate is not obscured.
  - Allow maximum available departure angle and prevent any potential interference.
  - Prevent possible interference with vehicles reverse sensors or camera detecting a tow ball mount as an obstruction during reversing.
  - Removes towball mount as an obstruction for when moving around the rear of the vehicle.
2. Trailboss recommends routine inspection of your towbar to ensure trouble free towing.
  - Bolt security and tension should be regularly inspected and checked for correct tension. Replace any worn or defective parts with suitable grade & class fasteners. Inspection should be requested to coincide with vehicle major services.
3. It is the owner's responsibility to ensure towing and down ball weight capacities of the towing vehicle are not exceeded.
  - Towing and down ball weights allowable may differ according to model variations. Please refer to owner's manual or vehicle dealer to confirm exact rating for your vehicle model variant.
  - It is not uncommon for the vehicle tow rating to differ from the towbar rating. When this occurs, the lesser rating must be adhered to.
  - For vehicles fitted with enhanced vehicle functions that may be altered/changed when towing i.e Trailer sway mitigation, blind spot detection, adaptive cruise control etc. Please consult owner's manual to understand changes enabled when towing and after towing.

### **WARRANTY INFORMATION:**

Trailboss Towbars are covered by a Lifetime Warranty.

Our goods come with guarantees that cannot be excluded under the Australian Consumer Law. You are entitled to a replacement or refund for a major failure and for compensation for any other reasonably foreseeable loss or damage. You are also entitled to have the goods repaired or replaced if the goods fail to be of acceptable quality and the failure does not amount to a major failure. For further details please contact customer service on 1800 812 017.



## PRO SERIES SILENT ANTI-RATTLE HITCH PIN

Your Trailboss towbar is equipped with a Pro Series Silent Anti-Rattle Hitch Pin technology to help reduce towbar tongue rattle in most driving conditions. Please ensure below instructions are understood and routine maintenance is carried out to ensure best towing experience.

Regularly inspect for wear and check the tightness of the Silent Anti-Rattle Hitch Pin. Follow instructions below to re-tighten the nut as necessary when movement and noise in the tow ball mount is noted.

- Before towing, ensure R-Clip is properly installed and hitch pin nut is installed and tensioned. Replacement parts are available from your Pro Series Distributor.

## TOWBALL MOUNT REMOVAL/INSTALLATION

### STEP 1

Insert Trailer Ball Mount (TBM) (a) into towbar hitchbox (b), aligning hole in TBM shank (c) with hole in hitchbox (d) (Fig. 1)

### STEP 2

Insert Silent Anti-Rattle Hitch Pin (e) through hole in hitchbox and hole in TBM shank (g); ensure the locators are inserted into the notches in the hitchbox (Fig. 2)

### STEP 3

Screw Silent Anti-Rattle Hitch Pin Nut (f) onto Smart Pin (g); tighten Smart Pin Nut until finger tight, ensuring TBM is restrained from up and down movement.

### STEP 4

Tighten Silent Anti-Rattle Hitch Pin Nut by turning nut a further 1/8th of a turn in the clockwise direction using a 24mm spanner (Fig. 4).

### STEP 5

Install Silent Anti-Rattle Hitch Pin R-Clip through the hole that provides best clearance or easiest access. (Fig. 5)

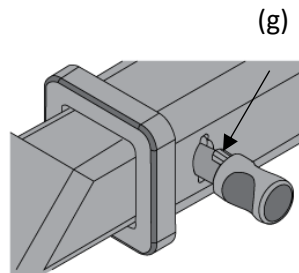
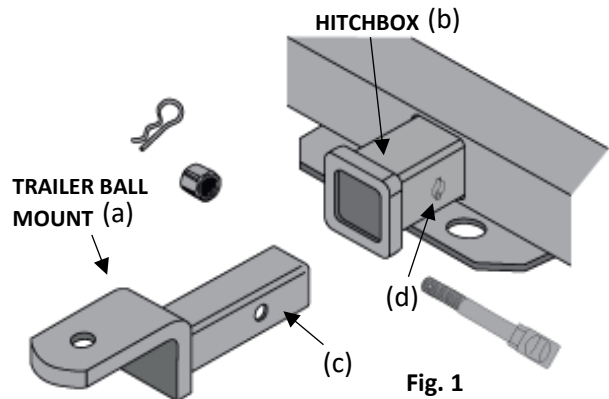

Fig. 2

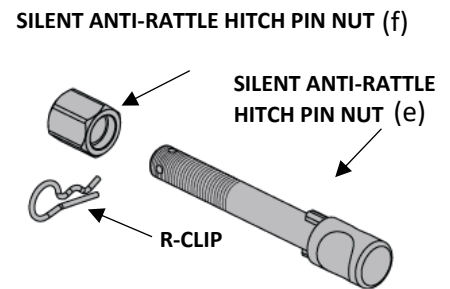

Fig. 3

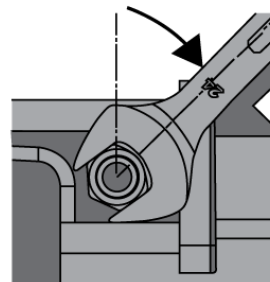

Fig. 4

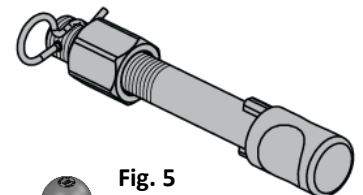

Fig. 5

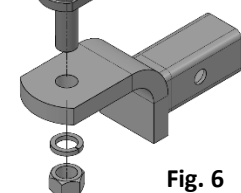

Fig. 6