

**PRODUCT DETAILS:**

---

<b>Part Number:</b>	QTKM32L	<b>Maximum Towing Braked:</b>	1300	kg
<b>ECU Number:</b>	04826	<b>Maximum Towing Unbraked:</b>	750	kg
<b>Tail Harness Length Required:</b>	1200 mm	<b>Maximum Static Ball Load:</b>	130	kg
<b>TBM/Lug Part Number:</b>	21407			

---

**FITTING DETAILS:**

---

<b>Towbar Installation Time:</b>	120 Mins.	<b>RPA Disable/Other:</b>	YES
<b>Total Installation Time:</b>	60 Mins.		
<b>Bumper Cut Required:</b>	Yes		

---

**Note:**

- RPA Disable via switch on dash.

### TRAILBOSS RECOMMENDS THAT INSTRUCTIONS ARE READ AND UNDERSTOOD COMPLETELY PRIOR TO FITMENT.

#### BEFORE YOU START:

Check all hardware items have been included refer to assembly diagram.  
Please ensure this towbar is only fitted to vehicle models as per Trailboss application guide.

#### Bumper Cuts

Vehicle and bumper variations can and do occur during vehicle manufacture after initial towbar design. Fitment of towbar to vehicle and accuracy of bumper cut must be assessed prior to any bumper modifications made. Incorrect bumper cuts are not covered under Trailboss warranty.

**NOTE: Bumper cuts need to be approached with care, refer to notes below.**

- Bumper centreline – where the centreline of the bumper needs to be determined, the installer must assess centre point by measurement of bumper width or determining two symmetrical reference points to give centreline.
- Bumper edge – To assist with accurate bumper cut measurement, reference to the start of the bumper edge is now being commonly used.
  - Measure from bottom edge along bumper and around corner to the 70 mm point (Figure 1).
  - Do not measure from visible bumper front of corner, upwards (Figure 2).

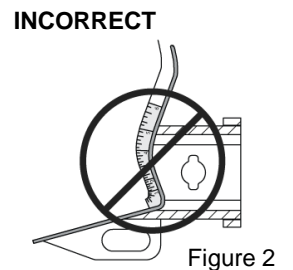
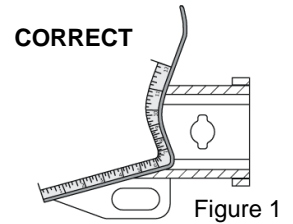

#### Drilling

- For any required drilling during installation, ensure that the area is clear of fuel, electrical & other components that may be damaged.
- All holes drilled into metal body panels shall have all burrs & swarf removed then coated with a suitable rust preventative paint.

#### Bolts/Fasteners

- Ensure that all hardware is fastened to correct torque as specified in this fitting instruction.
- All fasteners supplied with this product are used to achieve a specified clamp loading. If replacement is required ensure that fasteners of the same grade and class are used.

**NOTE: Achieving correct torque is critical to proper installation and responsibility of the installer. Towbar failures attributed to tension issues from over tightening or under tightening are not covered by Trailboss warranty.**

#### Product Labels

- a. Towbar load rating sticker provided with this product shall be conspicuously located on inside rear end of the driver's door.

#### WARNING:

**Do not, drill, cut, weld or otherwise modify the towbar.**

**FOR TOWING PURPOSES ONLY - This towbar is designed and tested by Trailboss to adhere to ADR 62/02 which provides only for the expected load demands of towing.**

### **i** TOWBAR ASSEMBLY DIAGRAM

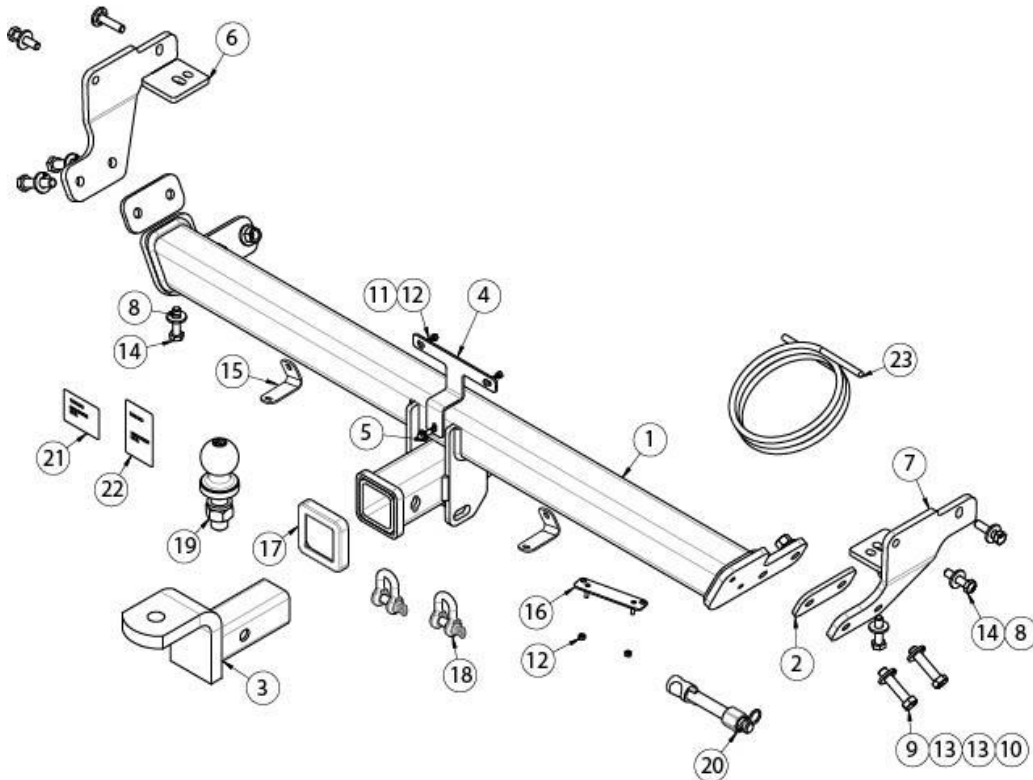

ITEM	DESCRIPTION	QTY
1	KIA NIRO WELDED ASSEMBLY	1
2	END PLATE	4
3	TRAILER BALL MOUNT	1
4	SENSOR BRACKET	1
5	TEK SCREW 14-20 HEX HD 22mm	3
6	SIDE ARM LHS	1
7	SIDE ARM RHS	1
8	WASHER PLAIN M10x25x3	12
9	SET SCREW HEX HD M12x55x1.25P	4
10	NUT HEX HD M12x1.75P	4
11	SCREW PAN HD M4x16x0.7P	2
12	NUT NYLOC HEX HD M4x0.7P	4

ITEM	DESCRIPTION	QTY
13	WASHER PLAIN M12x27x3	8
14	BOLT HEX HD M10x40x1.25P	6
15	BUMPER BRK	2
16	PLUG BRACKET	1
17	HITCH BOX COLLAR COVER	1
18	"D" SHACKLE 10mm	2
19	TOWBALL 50mm	1
20	SMART PIN SILVER	1
21	COMPLIANCE LABEL	1
22	LOAD RATING LABEL	1
23	WIRE LOOM	1

1. Open the tailgate.  
Remove the tail light cover to access the screws.  
Remove the 2x screws.  
Pull tail light rear ward and disconnect the wiring.  
  
Repeat for the other side

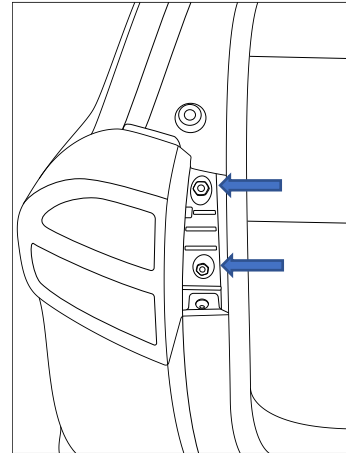

2. Remove the 1x screw and 1x scrivet clip.

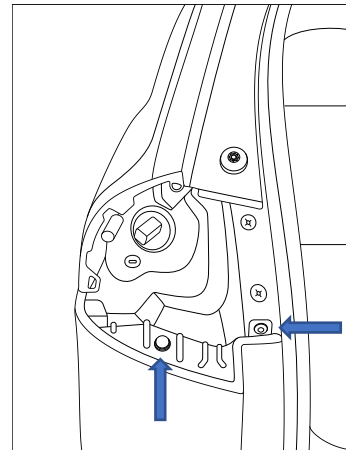

3. Remove the 3x screws and 1x scrivet.  
  
Repeat for the other side.

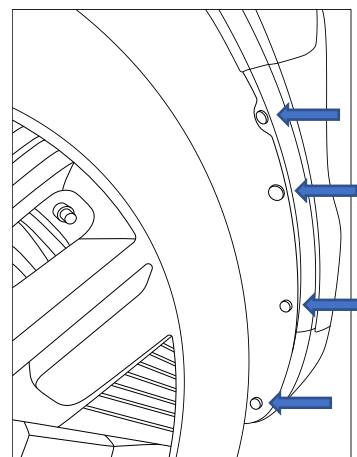

- 
4. Remove 4x scrivenets.

Repeat for the other side.

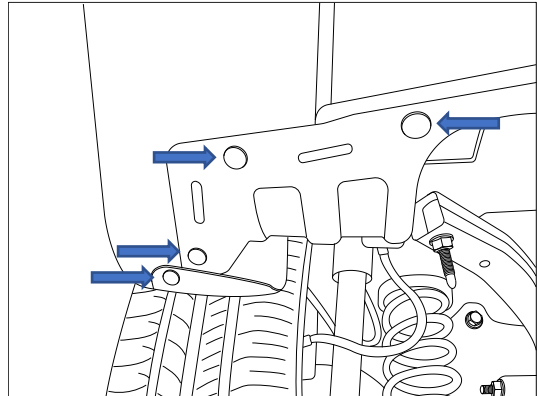

- 
5. Remove 2x bolts behind the bumper.

Repeat for the other side.

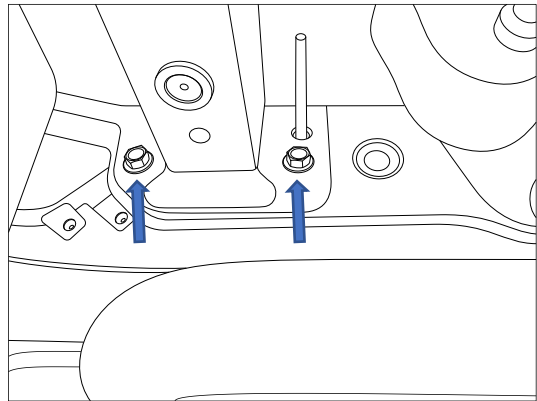

- 
6. Unclip the bumper and disconnect the bumper wire harness.

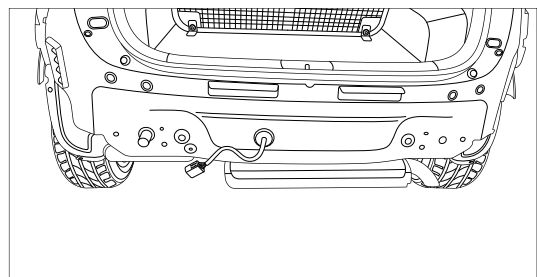

7. Place the side arm on the chassis.  
Loosely secure with 3x M10 bolts and 6x M10 washers.

Repeat for the other side.

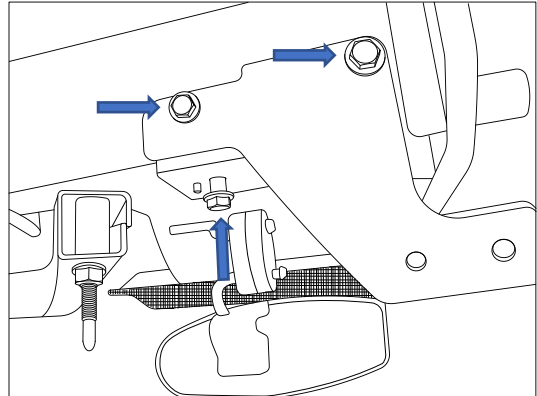

8. Place the cross tube between the side arms.  
Place the spacer between the cross tube and side arm.  
Secure with 2x M12 bolts, 4x M12 washers and 2x m12 nuts.

Repeat for the other side.

**Torque fasteners as follows:**

M10 x 1.25p = 48 Nm

M12 x 1.75P = 77 Nm

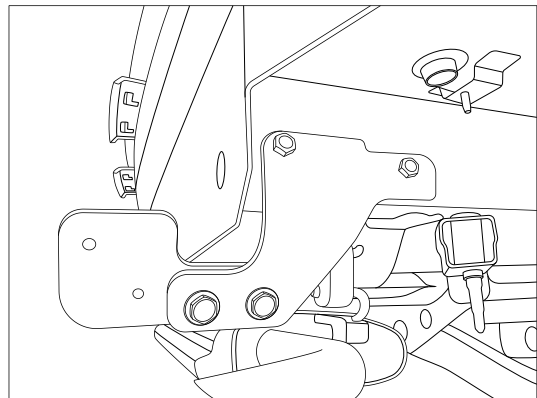

9. Fit the bumper tab and secure it with a tek screw.

Repeat to the other side.

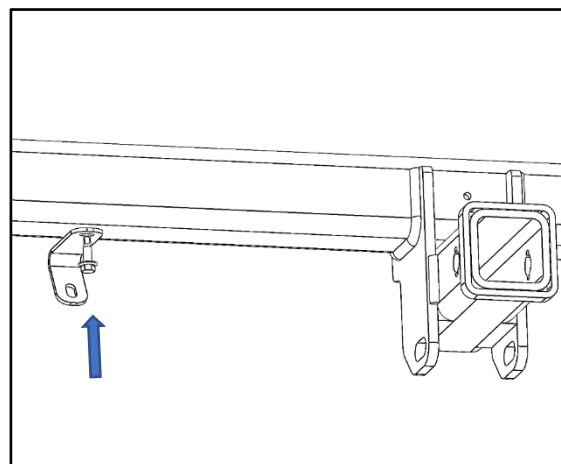

10. Remove 3x scrivet clips and wire harness from the impact beam.  
Unclip and discard the impact beam.

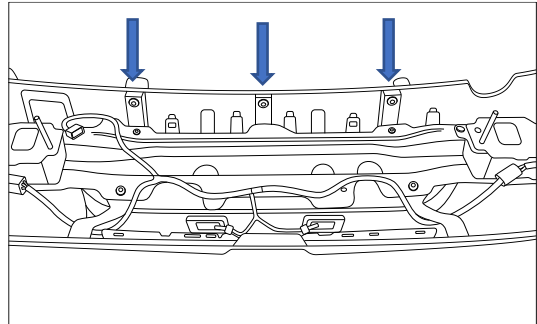

11. Place masking tape on the bumper outer skin  
Mark and cut out an area (90mm x160mm) to clear the hitch box.  
Be mindful to remove any wiring in the cut out area.

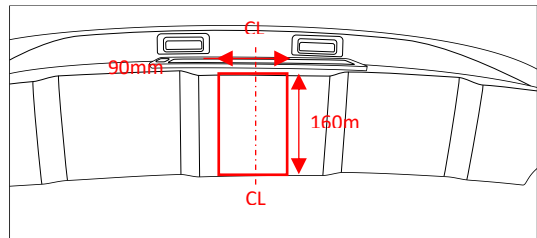

12. Place the sensor bracket to the towbar and secure with a tek screw.  
Secure the antenna to the bracket using 2x screws and 2x nuts.

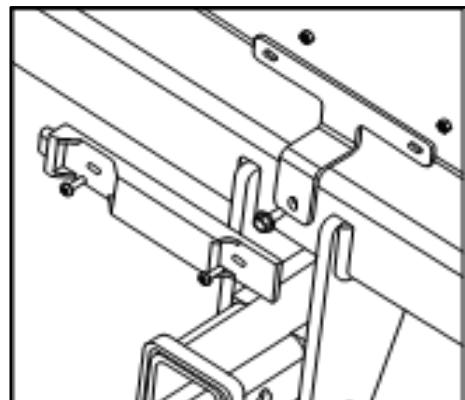

13. Locate the plug bracket and ensure the harness cable length is long enough.  
Drill 2x ø5mm holes 69mm apart.  
Remove all swarf and rough edges.

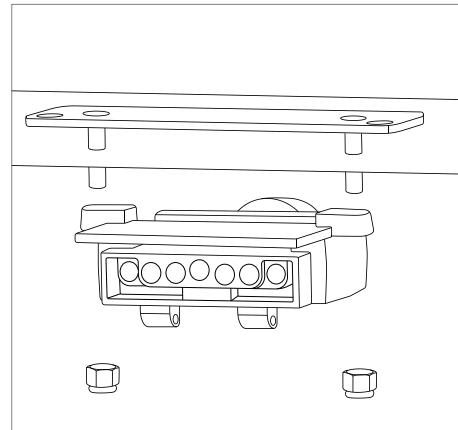

### IMPORTANT

Due to possible vehicle variations, always confirm any noted vehicle colour wires with a multi-meter to ensure the correct function is identified before soldering or scotch locking. For vehicle wires denoted with two colours (example; RED/GREEN) the first colour will always be the main wire colour while the second colour is the thinner trace colour on the wire.

14. In the rear cargo area, remove cargo blind and luggage compartment floor (1).  
15. Remove the spare wheel cover (2) and spare wheel surround (3). of 6  
16. Remove Rear Scuff Trim (4).

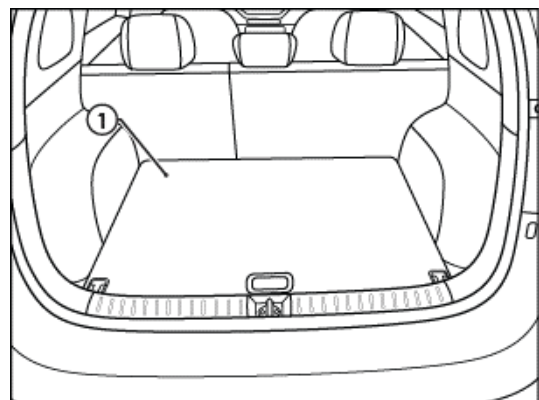
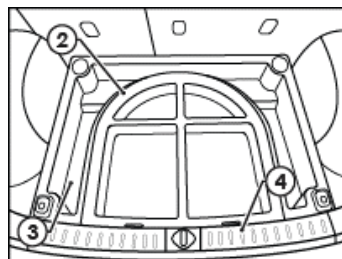



17. Remove the x2 bolts (1) securing the rear seat base (2).
18. Remove the Rear Seat Base (2) by pulling upwards.

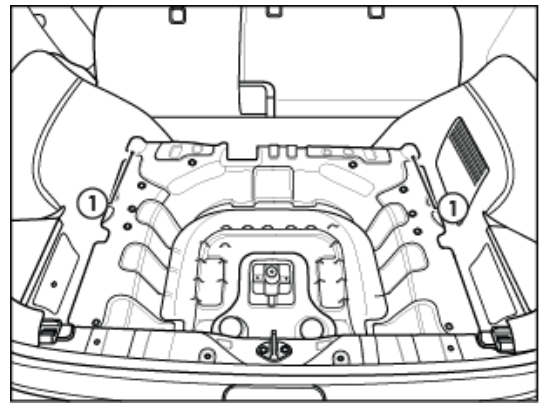
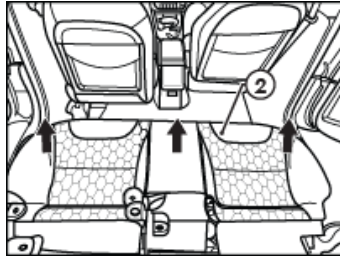

19. At the LHS rear door, dislodge the aperture seal (1).
20. Remove Phillips head screw (2).
21. Remove the LHS Door Still Trim (3) by carefully pulling in an upward direction.



22. Dislodge Drivers side door aperture seal (1).
23. Remove the scuff plate (2) by carefully prying with a trim tool in an upward direction.

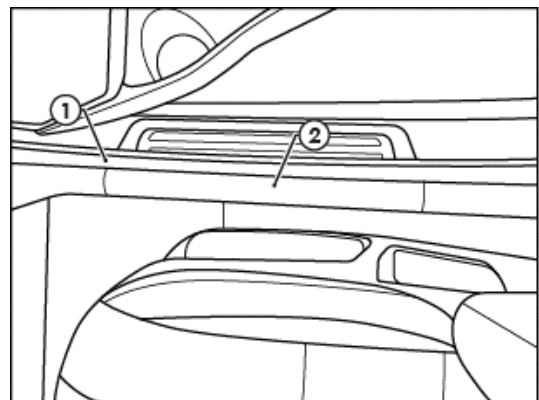

- 
24. At the driver side footwell, remove the bonnet lever **(1)**.
  25. Remove the Cowl Side Trim **(2)**.
  26. Remove Fuse Panel Cover.

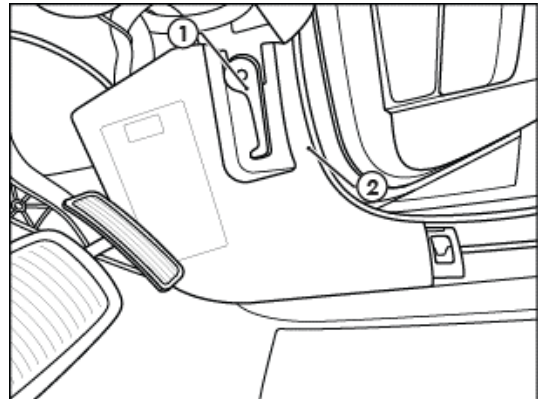

- 
27. Dislodge the RHS B-Pillar Trim **(1)**.

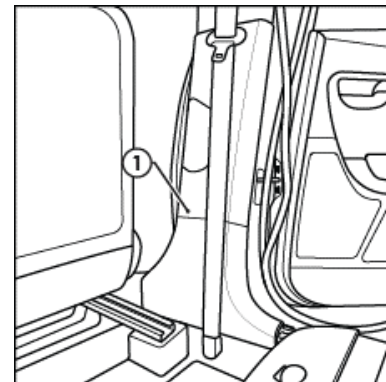

- 
28. Remove the Phillips head screws securing the LHS Rear Luggage Compartment Trim **(1)**.
  29. Dislodge the LHS Rear Luggage Compartment Trim **(1)** and disconnect any connectors from behind.
  30. Fold the LHS Rear Luggage Compartment Trim **(1)** to the centre of the vehicle.

**Repeat for RHS.**

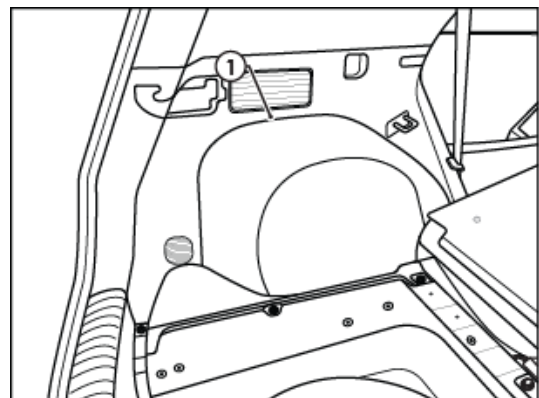

31. At the LHS tail lamp, patch in the LHS tail lamp connectors on the patch harness (102807-WL) (1) in between the vehicle tail light wiring (2) and the vehicle body wiring (3).
32. Route the Ground Ring Terminal Branch (4) further up the wheel arch.
33. Using the Supplied M6 Bolt secure ground terminal to the chassis grounding point (5).

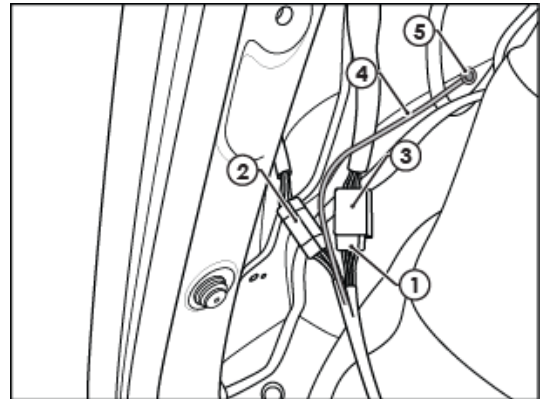

34. Route the patch harness (102807-WL) (1) wire towards the RHS Taillight.
35. Patch in the RHS tail lamp connectors on the patch harness (102807-WL) (1) in between the vehicle tail light wiring (2) and the vehicle body wiring (3).

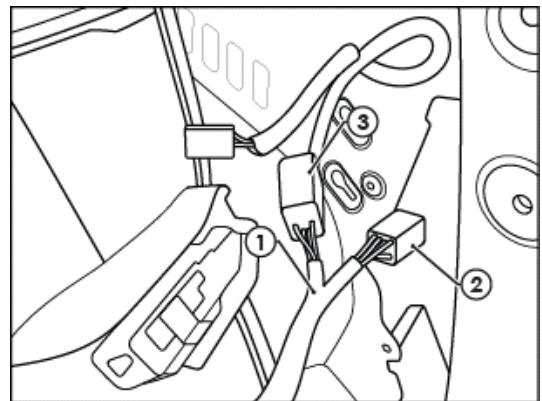

36. In the rear RHS compartment area, locate the side wall on RHS wheel arch.
37. Using a Cleaning pad, clean the back of the Trailer ECU and the flat surface on the vehicle where Trailer ECU would be mounted.
38. Peel off the backing from the supplied double-sided tape and adhere to the Trailer ECU.
39. Adhere the Trailer ECU onto the flat surface as shown (1).
40. Connect the Trailer ECU connector (2) to the Trailer ECU (3).

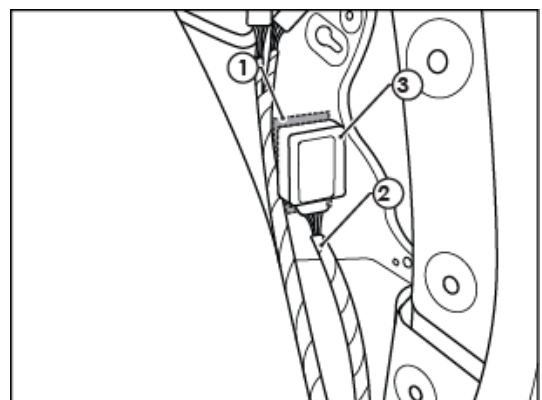

**Note: Mount the ECU, ensuring the connector is orientated downwards.**

41. Route the orange power wire (1) down the RHS towards the vehicle fuse panel near the driver's right knee.
42. Tuck the power wire under the trim as required.

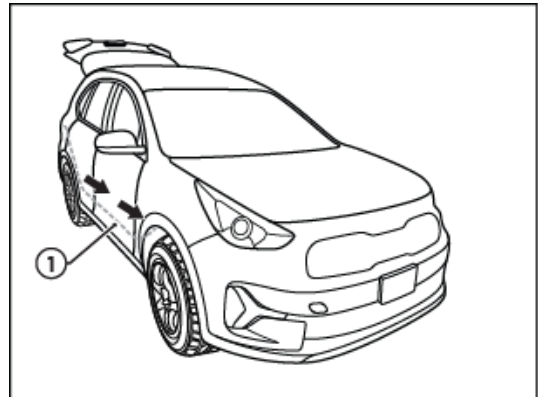

43. On the vehicle fuse box, remove the vehicle 25A fuse (1).
44. On the Add-A-Fuse, insert the supplied 20 amp fuse (3) into the Add-A-Fuse top slot (2) and then insert the vehicle 25A fuse (1) into the bottom slot.
45. In the orientation shown, insert the Add-A-Fuse (2) into the slot where the previously removed fuse was located.
46. Connect the Add-A-Fuse to the main harness (4).

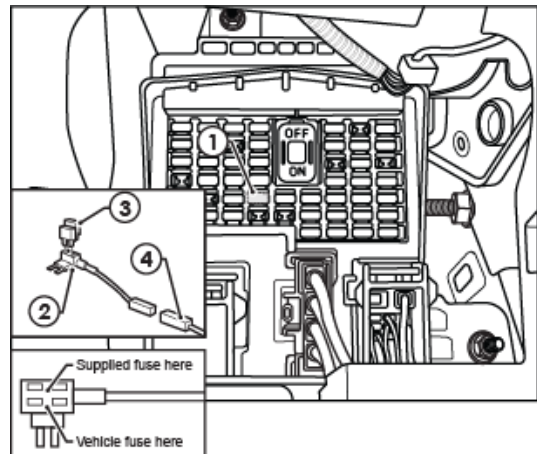

**Note: To maintain correct electrical operation, ensure you insert the fuse adaptor into the allocated slot and in the orientation shown.**

47. Drill a 30mm grommet hole in a suitable location (1) behind the RHS Wheel Arch area to enable the tail harness to be routed from the towbar to the ECU.

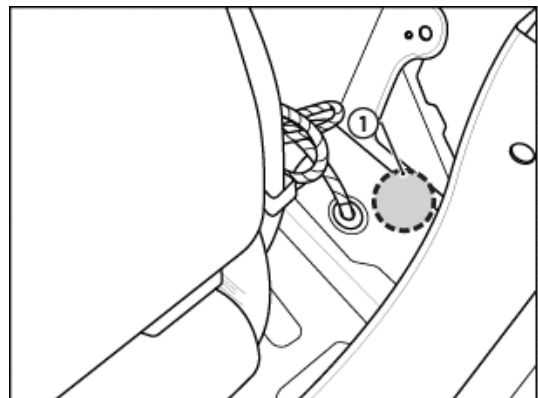

48. With the rear bumper removed, secure tail harness to towbar.
49. Route tail harness up through chassis and previously drilled 30mm hole.
50. Seat grommet in 30mm hole and route to trailer harness blue connector on patch loom.

**Note** Keep harness routing clear of all sharp edges, moving parts and places of extreme heat.

**Note:** Ensure grommet is seated correctly and makes a good seal.

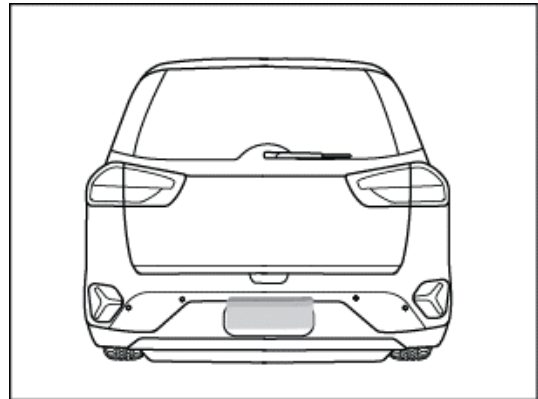

51. Connect the tail harness (tail length 1200mm) 8-way connector (1) to the trailer patch mating 8-way connector (2).
52. Secure all harness using supplied cable ties.
53. Test the trailer patch function using a light board or multi-meter.
54. Re-fit all removed parts (from step 1-6 and 14—30 in reverse) and secure all fasteners, ensuring there are no squeaks or rattles.
55. The RPA function can be disabled via a switch next to the gear shifter.
56. Place the fitting instructions in the glove box after fitment.

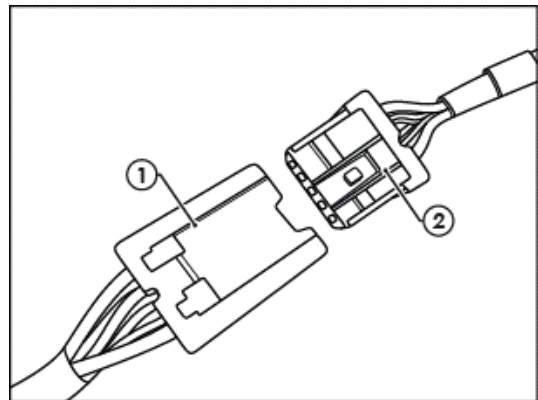

**THANK YOU FOR PURCHASING HAYMAN REESE.  
WITH CORRECT MAINTENANCE AND CARE THIS PRODUCT WILL  
PROVIDE A LIFETIME OF TROUBLE-FREE OPERATION.**

## **TOWBAR MAINTENANCE AND CARE:**

1. Hayman Reese recommend that the towbar LUG or TBM (tow ball Mount) Pull Pin and R-clip are removed and stored when not in use. Removal of LUG or TBM (tow ball mount) is advisable when not in use to assist with any of the following.
  - Ensure rear number plate is not obscured.
  - Allow maximum available departure angle and prevent any potential interference.
  - Prevent possible interference with vehicles reverse sensors or camera detecting a tow ball mount as an obstruction during reversing.
  - Removes towball mount as an obstruction for when moving around the rear of the vehicle.
2. Hayman Reese recommends routine inspection of your towbar to ensure trouble free towing.
  - Bolt security and tension should be regularly inspected and checked for correct tension. Replace any worn or defective parts with suitable grade & class fasteners. Inspection should be requested to coincide with vehicle major services.
3. It is the owner's responsibility to ensure towing and down ball weight capacities of the towing vehicle are not exceeded.
  - Towing and down ball weights allowable may differ according to model variations. Please refer to owner's manual or vehicle dealer to confirm exact rating for your vehicle model variant.
  - It is not uncommon for the vehicle tow rating to differ from the towbar rating. When this occurs, the lesser rating must be adhered to.
  - For vehicles fitted with enhanced vehicle functions that may be altered/changed when towing i.e Trailer sway mitigation, blind spot detection, adaptive cruise control etc. Please consult owner's manual to understand changes enabled when towing and after towing.

## **WARRANTY INFORMATION:**

Hayman Reese Towbars are covered by a Lifetime Warranty.  
Our goods come with guarantees that cannot be excluded under the Australian Consumer Law. You are entitled to a replacement or refund for a major failure and for compensation for any other reasonably foreseeable loss or damage. You are also entitled to have the goods repaired or replaced if the goods fail to be of acceptable quality and the failure does not amount to a major failure.  
For further details please visit [www.haymanreese.com.au/warranty](http://www.haymanreese.com.au/warranty) or contact customer service on 1800 812 017 or [info@haymanreese.com.au](mailto:info@haymanreese.com.au).





## CUSTOMER INFORMATION

PLACE THESE INSTRUCTIONS IN THE  
VEHICLE'S GLOVEBOX AFTER INSTALLATION

**THANK YOU FOR PURCHASING TRAILBOSS. WITH CORRECT MAINTENANCE AND CARE  
THIS PRODUCT WILL PROVIDE A LIFETIME OF TROUBLE-FREE OPERATION.**

### TOWBAR MAINTENANCE AND CARE:

1. Trailboss recommend that the towbar LUG or TBM (Trailer Ball Mount) Pull Pin and R-clip are removed and stored when not in use. Removal of LUG or TBM (Trailer Ball Mount) is advisable when not in use to assist with any of the following.
  - Ensure rear number plate is not obscured.
  - Allow maximum available departure angle and prevent any potential interference.
  - Prevent possible interference with vehicles reverse sensors or camera detecting a tow ball mount as an obstruction during reversing.
  - Removes towball mount as an obstruction for when moving around the rear of the vehicle.
2. Trailboss recommends routine inspection of your towbar to ensure trouble free towing.
  - Bolt security and tension should be regularly inspected and checked for correct tension. Replace any worn or defective parts with suitable grade & class fasteners. Inspection should be requested to coincide with vehicle major services.
3. It is the owner's responsibility to ensure towing and down ball weight capacities of the towing vehicle are not exceeded.
  - Towing and down ball weights allowable may differ according to model variations. Please refer to owner's manual or vehicle dealer to confirm exact rating for your vehicle model variant.
  - It is not uncommon for the vehicle tow rating to differ from the towbar rating. When this occurs, the lesser rating must be adhered to.
  - For vehicles fitted with enhanced vehicle functions that may be altered/changed when towing i.e Trailer sway mitigation, blind spot detection, adaptive cruise control etc. Please consult owner's manual to understand changes enabled when towing and after towing.

### WARRANTY INFORMATION:

Trailboss Towbars are covered by a Lifetime Warranty.

Our goods come with guarantees that cannot be excluded under the Australian Consumer Law. You are entitled to a replacement or refund for a major failure and for compensation for any other reasonably foreseeable loss or damage. You are also entitled to have the goods repaired or replaced if the goods fail to be of acceptable quality and the failure does not amount to a major failure.

For further details please contact customer service on 1800 812 017.

## PRO SERIES SILENT ANTI-RATTLE HITCH PIN

Your Trailboss towbar is equipped with a Pro Series Silent Anti-Rattle Hitch Pin technology to help reduce towbar tongue rattle in most driving conditions. Please ensure below instructions are understood and routine maintenance is carried out to ensure best towing experience.

Regularly inspect for wear and check the tightness of the Silent Anti-Rattle Hitch Pin. Follow instructions below to re-tighten the nut as necessary when movement and noise in the tow ball mount is noted.

- Before towing, ensure R-Clip is properly installed and hitch pin nut is installed and tensioned. Replacement parts are available from your Pro Series Distributor.

## TOWBALL MOUNT REMOVAL/INSTALLATION

### STEP 1

Insert Trailer Ball Mount (TBM) (a) into towbar hitchbox (b), aligning hole in TBM shank (c) with hole in hitchbox (d) (Fig. 1)

### STEP 2

Insert Silent Anti-Rattle Hitch Pin (e) through hole in hitchbox and hole in TBM shank (g); ensure the locators are inserted into the notches in the hitchbox (Fig. 2)

### STEP 3

Screw Silent Anti-Rattle Hitch Pin Nut (f) onto Smart Pin (g); tighten Smart Pin Nut until finger tight, ensuring TBM is restrained from up and down movement.

### STEP 4

Tighten Silent Anti-Rattle Hitch Pin Nut by turning nut a further 1/8th of a turn in the clockwise direction using a 24mm spanner (Fig. 4).

### STEP 5

Install Silent Anti-Rattle Hitch Pin R-Clip through the hole that provides best clearance or easiest access. (Fig. 5)

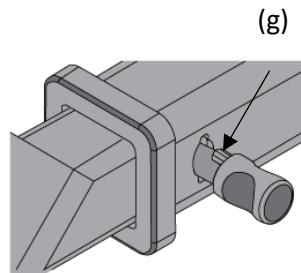
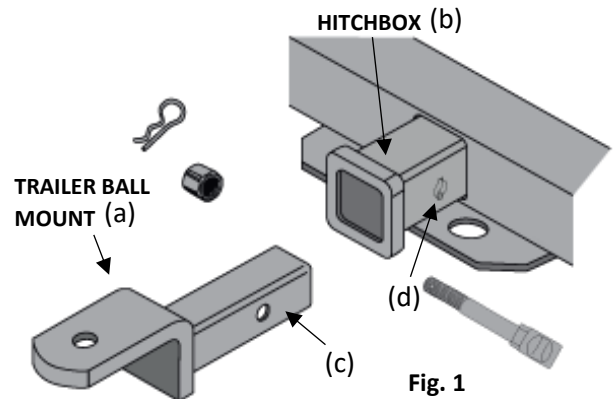

Fig. 2

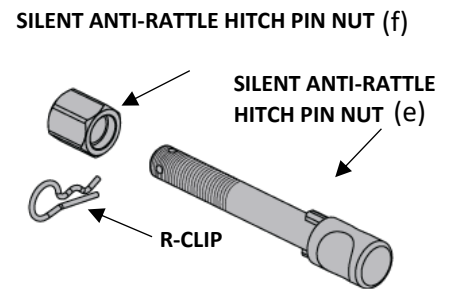

Fig. 3

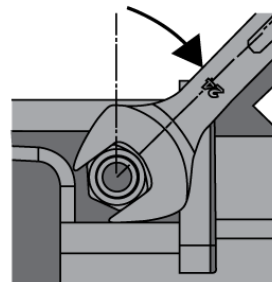

Fig. 4

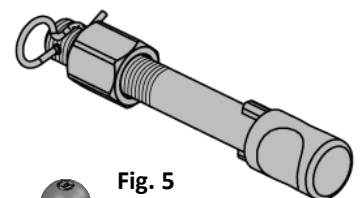

Fig. 5

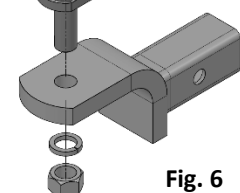

Fig. 6