

PRODUCT DETAILS:

Part Number:	QTLD007L	Maximum Towing Braked:	2800	kg
ECU Number:	04826	Maximum Towing Unbraked:	750	kg
Tail Harness Length Required:	1800 mm	Maximum Static Ball Load:	280	kg
TBM/Lug Part Number:	21389			

FITTING DETAILS:

Towbar Installation Time:	50 Mins.	RPA Disable/Other:	YES
Total Installation Time:	110 Mins.		
Bumper Cut Required:	No		

Note:

- Electric Brake = Brake Prep Connector.
- Use 04937 tail for RPA disable.

TRAILBOSS RECOMMENDS THAT INSTRUCTIONS ARE READ AND UNDERSTOOD COMPLETELY PRIOR TO FITMENT.

BEFORE YOU START:

Check all hardware items have been included refer to assembly diagram.
Please ensure this towbar is only fitted to vehicle models as per Trailboss application guide.

Bumper Cuts

Vehicle and bumper variations can and do occur during vehicle manufacture after initial towbar design. Fitment of towbar to vehicle and accuracy of bumper cut must be assessed prior to any bumper modifications made. Incorrect bumper cuts are not covered under Trailboss warranty.

NOTE: Bumper cuts need to be approached with care, refer to notes below.

- Bumper centreline – where the centreline of the bumper needs to be determined, the installer must assess centre point by measurement of bumper width or determining two symmetrical reference points to give centreline.
- Bumper edge – To assist with accurate bumper cut measurement, reference to the start of the bumper edge is now being commonly used.
 - Measure from bottom edge along bumper and around corner to the 70 mm point (Figure 1).
 - Do not measure from visible bumper front of corner, upwards (Figure 2).

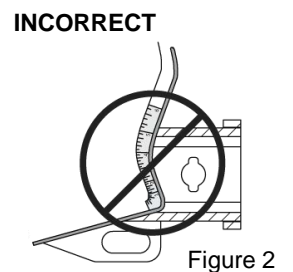
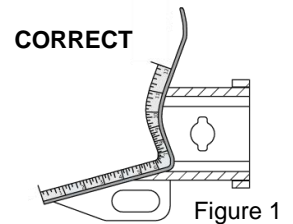

Drilling

- For any required drilling during installation, ensure that the area is clear of fuel, electrical & other components that may be damaged.
- All holes drilled into metal body panels shall have all burrs & swarf removed then coated with a suitable rust preventative paint.

Bolts/Fasteners

- Ensure that all hardware is fastened to correct torque as specified in this fitting instruction.
- All fasteners supplied with this product are used to achieve a specified clamp loading. If replacement is required ensure that fasteners of the same grade and class are used.

NOTE: Achieving correct torque is critical to proper installation and responsibility of the installer. Towbar failures attributed to tension issues from over tightening or under tightening are not covered by Trailboss warranty.

Product Labels

- a. Towbar load rating sticker provided with this product shall be conspicuously located on inside rear end of the driver's door.

WARNING:

Do not, drill, cut, weld or otherwise modify the towbar.

FOR TOWING PURPOSES ONLY - This towbar is designed and tested by Trailboss to adhere to ADR 62/02 which provides only for the expected load demands of towing.

i TOWBAR ASSEMBLY DIAGRAM

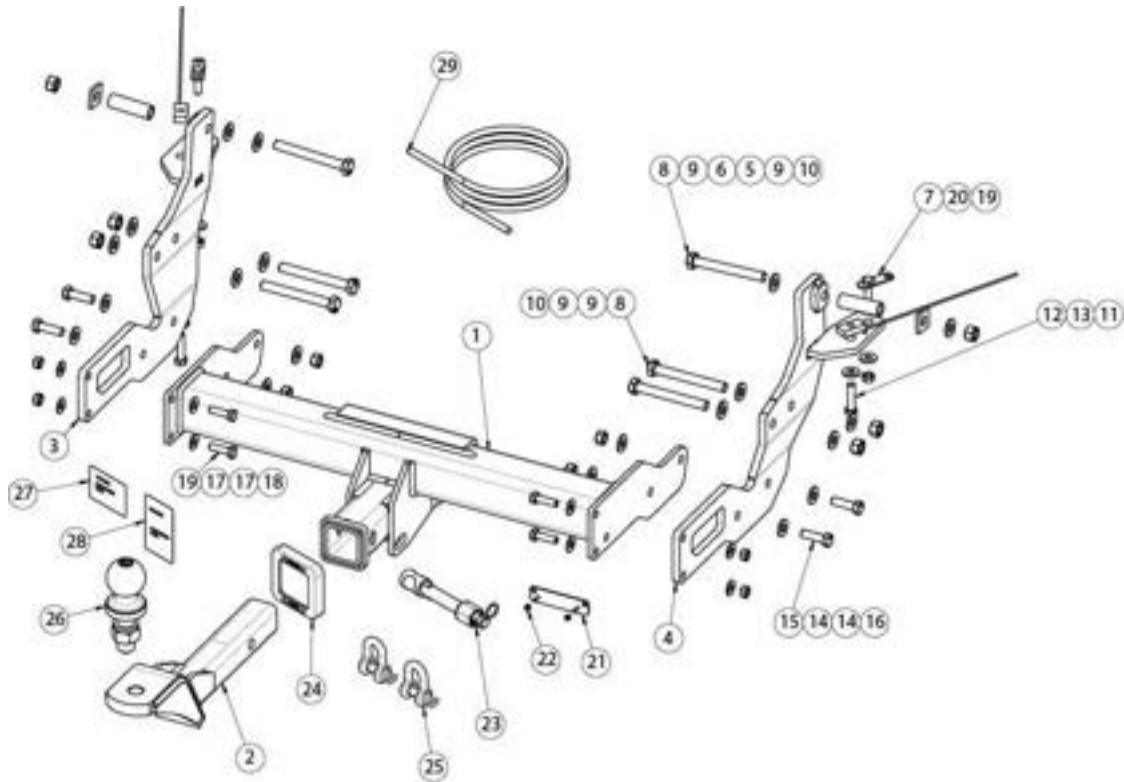

ITEM	DESCRIPTION	QTY
1	LDV DELIVER 9 CL4 WELDED ASSY	1
2	TRAILER BALL MOUNT	1
3	SIDE ARM ASSEMBLY LH	1
4	SIDE ARM ASSEMBLY RH	1
5	SPACER PLATE	2
6	CRUSH TUBE	2
7	T BOLT ASSEMBLY	2
8	BOLT HEX HD M14x120x2.0P	6
9	WASHER PLAIN M14x28x3	12
10	NUT HEX HD M14x2.0P	6
11	T PLATE M10x1.5P & WIRE 300mm	2
12	BOLT HEX HD M10x45x1.5P	2
13	WASHER PLAIN M10x25.4x3	2
14	WASHER PLAIN 1/2"	8
15	SET SCREW M12 X 40 X 1.75P G8.8	4

ITEM	DESCRIPTION	QTY
16	NUT HEX HD M12x1.75P	4
17	WASHER PLAIN M10x23x2	8
18	SET SCREW HEX HD M10x35x1.5P	4
19	NUT HEX HD M10x1.5P	6
20	WASHER PLAIN M10x25x3	4
21	PLUG BRACKET	1
22	NUT NYLOC HEX HD M4x0.7P	2
23	SMART PIN GOLD	1
24	HITCH BOX COLLAR COVER	1
25	"D" SHACKLE 10mm	2
26	TOWBALL 50mm	1
27	COMPLIANCE LABEL	1
28	LOAD RATING LABEL	1
29	WIRING LOOM	1

1. Open rear door to expose the spare wheel mechanism.
Use the appropriate tools and lower the spare wheel.

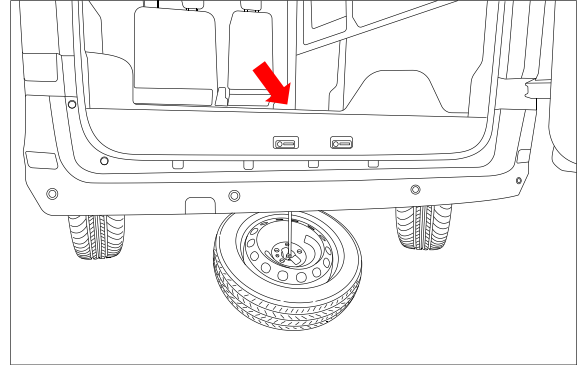

2. From under vehicle, remove and discard the 2 x bolts with washers and nuts from the step bracket.

Repeat for other side.

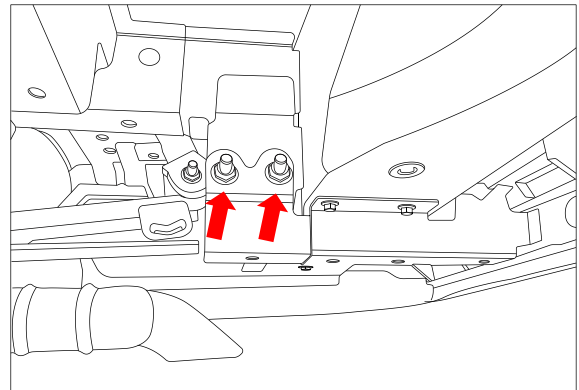

3. Note the different mounting holes to be used on the side arm assembly are dependent on the vehicle model. All other mounting positions are common.

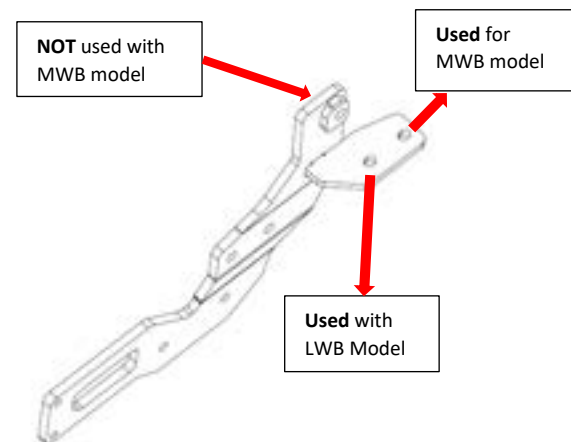

4. For the LWB model.

From under vehicle, feed the tapped plate on wire through the front hole into the chassis rail and align the threads with the rear mounting hole.

Repeat for other side.

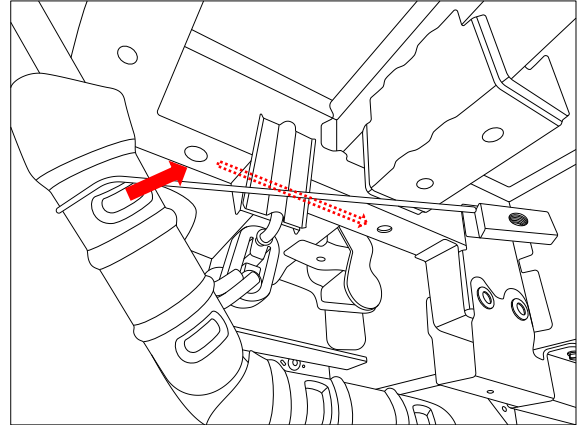

5. For the MWB model.

From under the vehicle insert the T-Bolt assembly into the mounting hole.

Repeat for other side.

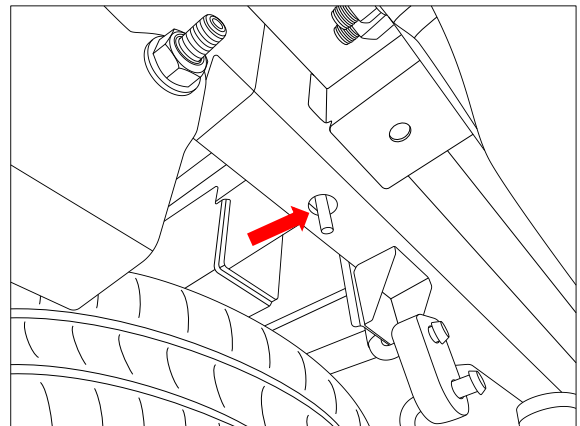

6. For LWB model only

Insert the crush tube into the chassis rail and push it through to the outside face. Ensure it does not fall into the chassis rail.

Repeat for other side.

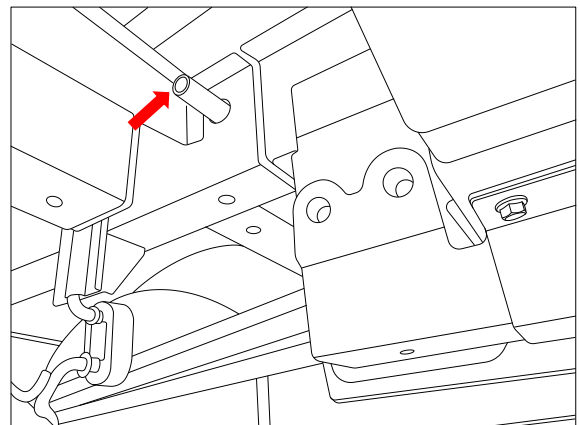

7. For LWB model

Lift the side arm up to the chassis rail and loosely secure the side to the top mounting position with 1 x M14 bolt complete with 2 x washers, 1 x spacer plate and 1 x nut per bolt (ensure the crush tube is in position).

Loosely secure the sides with 2 x M14 bolts complete with 2 x washers and 1 x nut per bolt.

Loosely secure to the bottom of the chassis rail using the tapped plate with 1 x M10 x 45 bolt complete with 1 x washer.

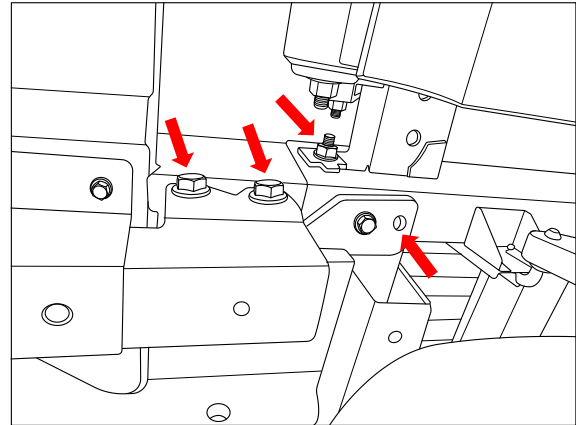

Repeat for other side.

8. For MWB model

Lift the side arm up to the chassis rail and loosely secure the sides with 2 x M14 bolts complete with 2 x washers and 1 x nut per bolt.

Loosely secure to the bottom of the chassis rail using the T-Bolt (fitted in step 8) complete with 1 x washer and 1 x M10 nut.

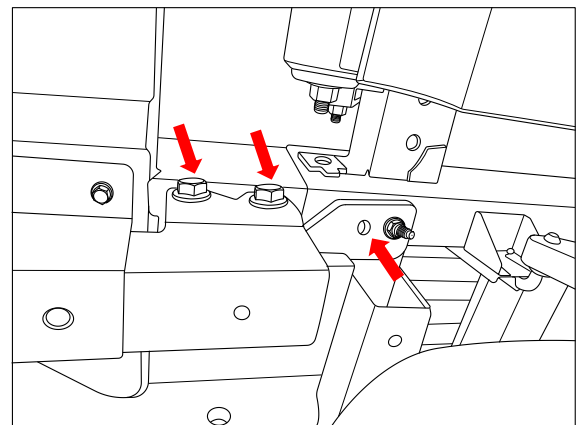

Repeat for other side.

9. For LWB and MWB models

Lift the crosstube up to the side arms and loosely secure the rearmost (of vehicle) positions with 2 x M10 x 35 bolts complete with 2 x washers and 1 x M10 nut per bolt.

10. Loosely secure the forward positions with 2 x M12 bolts complete with 2 x washers and 1 x M12 nut per bolt.

Repeat steps 12 and 13 for the other side.

Tighten all fasteners to the following torques:

M10 x 1.5 x 35 GR8.8	: 44Nm
M10 x 1.5 x 45 GR10.9	: 62Nm
M12 x 1.75 GR8.8	: 77Nm
M14 x 2 GR10.9	: 175Nm

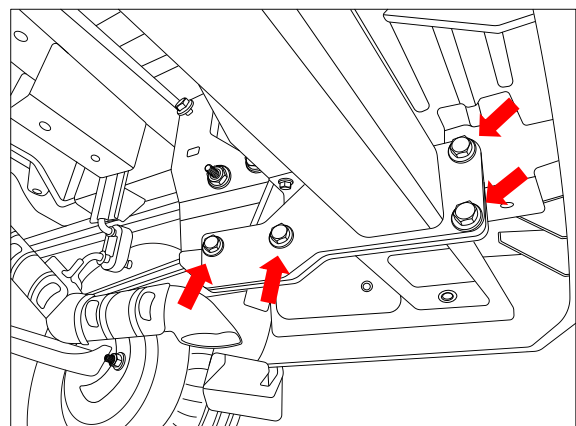

-
11. At the LHS wheel arch, remove the fasteners, that secure the mudflap.
Dislodge the small section of the wheel arch to gain access to the 2x Phillips's head screw securing the side bumper trim.
Dislodge and remove the side bumper trim

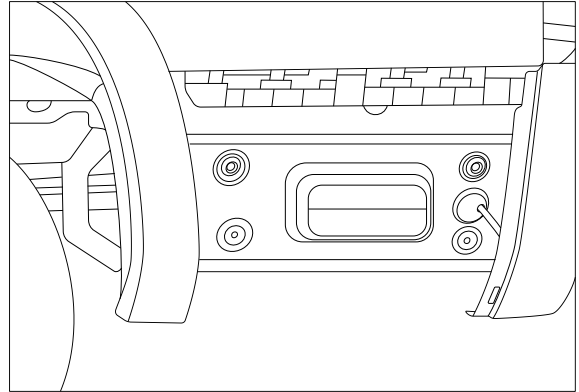

-
12. At an appropriate position on the bumper, mark out and drill 2x \varnothing 5mm holes 69mm apart on bumper skin to support plug bracket.

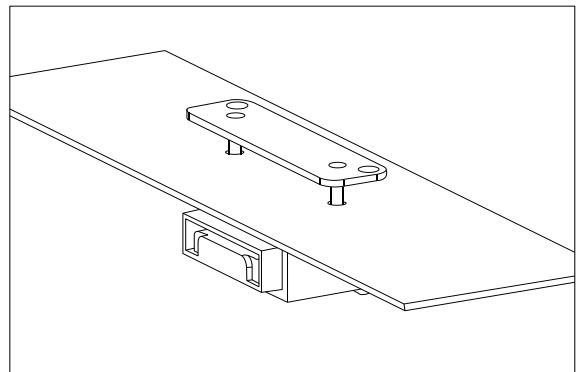

IMPORTANT

Due to possible vehicle variations, always confirm any noted vehicle colour wires with a multi-meter to ensure the correct function is identified before soldering or scotch locking. For vehicle wires denoted with two colours (example; RED/GREEN) the first colour will always be the main wire colour while the second colour is the thinner trace colour on the wire.

-
13. Disconnect the vehicle battery negative terminal under the driver's seat (1).

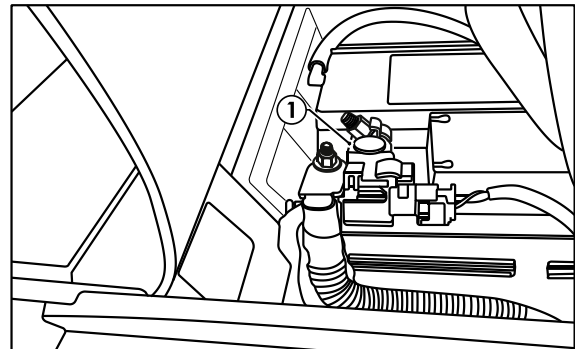

-
14. Inside the van, remove the air vents (1) covering the LHS tail light bolts.
15. Remove the LHS panel (2) by removing all trim clips.

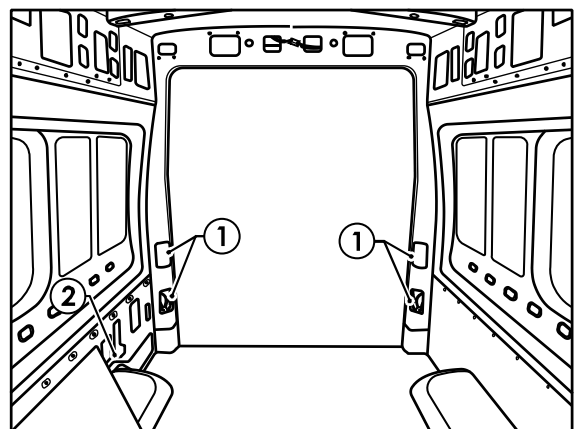

16. Remove the two bolts at the back of the LHS tail lamp.
17. Lift up the 3 screw covers on the LHS lamp fascia and remove 3 screws (1).
18. Dislodge and remove the tail lamp (2) by first disconnecting the wiring harness.

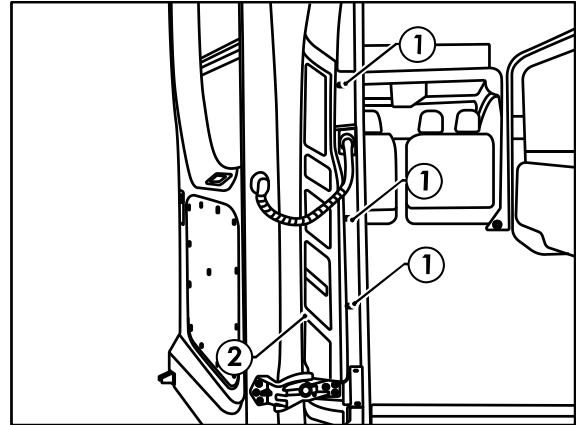

19. At the LHS tail lamp, unseat the grommet on the vehicle harness (1) and push the tail light connector (2) into the vehicle.
20. From inside the vehicle retrieve the tail light connector and plug connector into patch harness (102595-WL) mating connector (3).
21. Feed the new tail light connector (4) on the patch harness out through the hole and seat the new angled grommet (5) in the hole.
22. Bundle and tie up excess harness inside the vehicle using the supplied cable ties.

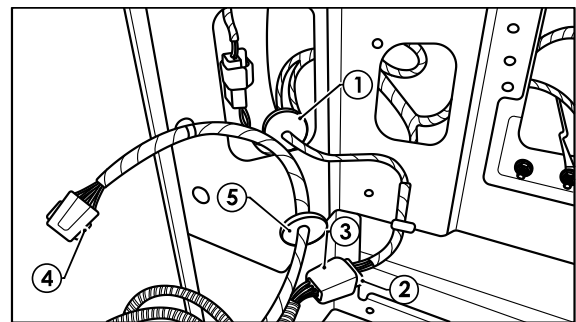

23. From inside the vehicle route the long green wire over the archway towards the RHS tail lamp.
24. Route the ECU connector up towards the vent hole.
25. Using an alcohol wipe, clean the LHS inner sheet metal area and the underside of the ECU (04826) (1).
26. Connect the trailer patch 12-way connector to the ECU.
27. Apply double sided tape to the ECU and secure it to the vehicle sheet metal.

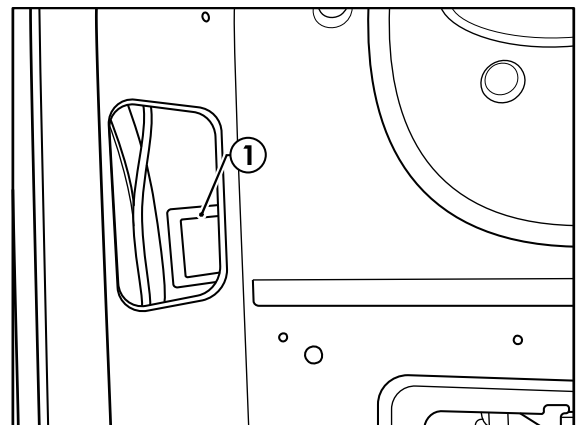

Note: Mount the ECU, ensuring the connector is orientated downwards.

28. At the RHS tail lamp harness, peel back some of the tape (1) covering the harness inside the vehicle.
29. Using a multi-meter, following the table below, connect the ezy-taps (2) to the mating tail light harness wire (3). Then connect the trailer patch wire (4) to the ezy-tap (2).

Function	Trailer Patch	Vehicle Harness
Green / Black	Green / Black	Red / Black

Note: The first wire specified is the main colour and the second wire is the trace colour.

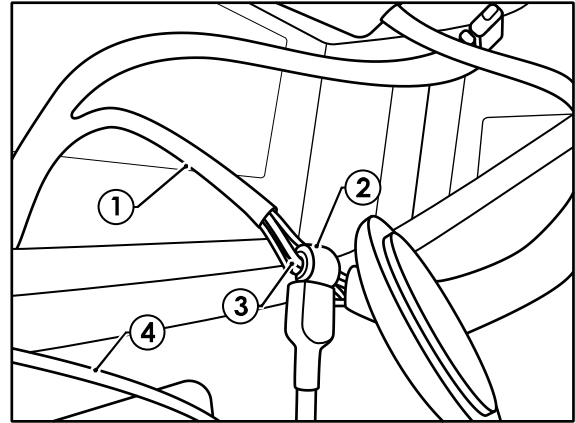

30. At the Fuse Box in the Engine Bay, connect the power wire ring terminal (1) to the fuse box distribution stud (2).

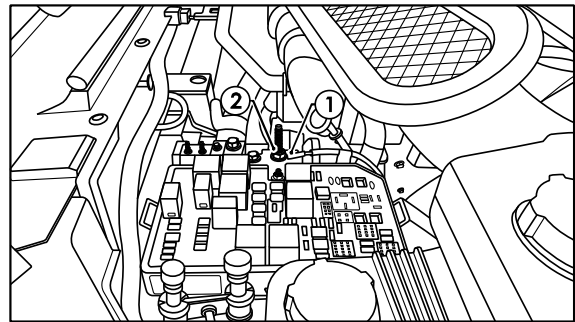

31. Following the existing vehicle wiring, route the orange power wire (1) down firewall and along the outside of the LHS chassis rail (2), above the fuel tank (3), towards the rear of the vehicle.

Note: Keep harness routing clear of all sharp edges, moving parts and places of extreme heat.

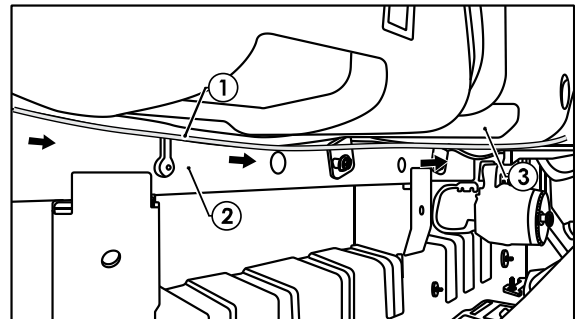

32. At the rear of the vehicle, remove the air vent on the LHS to enable the tail harness to be routed from the towbar to the ECU.
33. Secure tail harness to towbar and route tail harness towards LHS rear air vent.
34. House the male terminal on the orange power wire (1) into the spare cavity on the blue connector (2) on the tail harness (3) (04937).

Note: Keep harness routing clear of all sharp edges, moving parts and places of extreme heat.

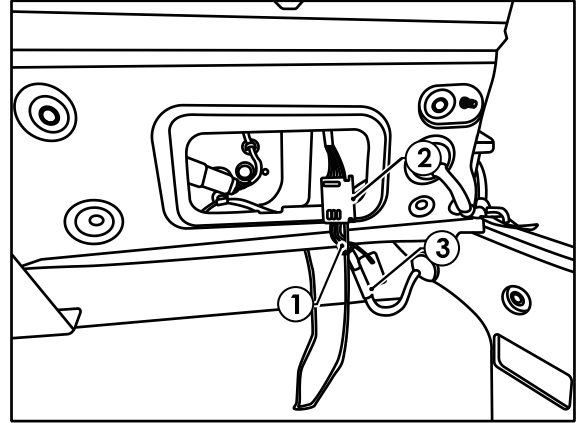

35. Feed the tail harness 8-way connector (1) up the air vent to the vehicle cabin and connect to the trailer patch mating 8-way connector (2).
36. Connect the ring terminal (3) to one of the vehicle earth points (4).
37. For Automatic RPA disable, peel back some tape on the vehicle harness (5) leading to the RPA ECU (6).

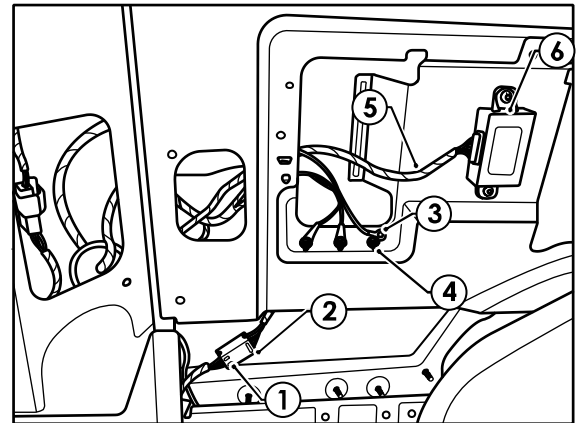

38. Cut the RPA ground wire (1) 100mm back from the vehicle RPA ECU.
39. The ground wire is the Blue/Green wire leading into Pin 6 on the ECU connector (2).
40. Strip and crimp the tail harness GREY wire to one side of the Blue/Green wire (1).
41. Strip and crimp the tail harness GREY/BLACK wire to the other side of the Blue/Green wire (1).
42. Insulate using electrical tape

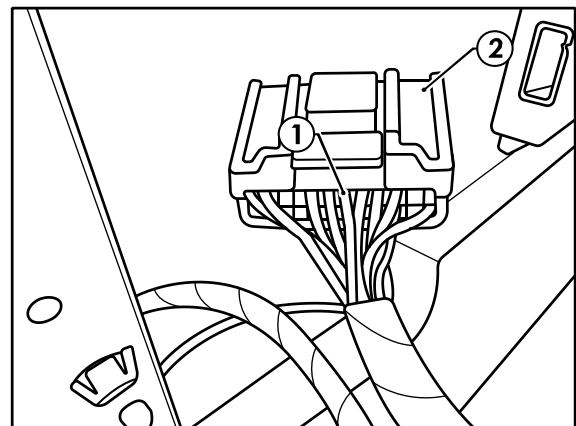

-
43. Secure all harness using supplied Cable Ties.
 44. Test the trailer patch function using a light board or multi-meter.
 45. Re-fit all removed parts and secure all fasteners, ensuring there are no squeaks or rattles.
 46. Place the fitting instructions in the glove box after fitment.

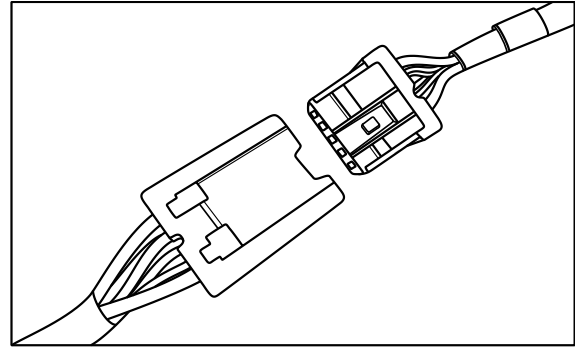



CUSTOMER INFORMATION

PLACE THESE INSTRUCTIONS IN THE
VEHICLE'S GLOVEBOX AFTER INSTALLATION

**THANK YOU FOR PURCHASING TRAILBOSS. WITH CORRECT MAINTENANCE AND CARE
THIS PRODUCT WILL PROVIDE A LIFETIME OF TROUBLE-FREE OPERATION.**

TOWBAR MAINTENANCE AND CARE:

1. Trailboss recommend that the towbar LUG or TBM (Trailer Ball Mount) Pull Pin and R-clip are removed and stored when not in use. Removal of LUG or TBM (Trailer Ball Mount) is advisable when not in use to assist with any of the following.
 - Ensure rear number plate is not obscured.
 - Allow maximum available departure angle and prevent any potential interference.
 - Prevent possible interference with vehicles reverse sensors or camera detecting a tow ball mount as an obstruction during reversing.
 - Removes towball mount as an obstruction for when moving around the rear of the vehicle.
2. Trailboss recommends routine inspection of your towbar to ensure trouble free towing.
 - Bolt security and tension should be regularly inspected and checked for correct tension. Replace any worn or defective parts with suitable grade & class fasteners. Inspection should be requested to coincide with vehicle major services.
3. It is the owner's responsibility to ensure towing and down ball weight capacities of the towing vehicle are not exceeded.
 - Towing and down ball weights allowable may differ according to model variations. Please refer to owner's manual or vehicle dealer to confirm exact rating for your vehicle model variant.
 - It is not uncommon for the vehicle tow rating to differ from the towbar rating. When this occurs, the lesser rating must be adhered to.
 - For vehicles fitted with enhanced vehicle functions that may be altered/changed when towing i.e Trailer sway mitigation, blind spot detection, adaptive cruise control etc. Please consult owner's manual to understand changes enabled when towing and after towing.

WARRANTY INFORMATION:

Trailboss Towbars are covered by a Lifetime Warranty.

Our goods come with guarantees that cannot be excluded under the Australian Consumer Law. You are entitled to a replacement or refund for a major failure and for compensation for any other reasonably foreseeable loss or damage. You are also entitled to have the goods repaired or replaced if the goods fail to be of acceptable quality and the failure does not amount to a major failure.

For further details please contact customer service on 1800 812 017.

PRO SERIES SILENT ANTI-RATTLE HITCH PIN

Your Trailboss towbar is equipped with a Pro Series Silent Anti-Rattle Hitch Pin technology to help reduce towbar tongue rattle in most driving conditions. Please ensure below instructions are understood and routine maintenance is carried out to ensure best towing experience.

Regularly inspect for wear and check the tightness of the Silent Anti-Rattle Hitch Pin. Follow instructions below to re-tighten the nut as necessary when movement and noise in the tow ball mount is noted.

- Before towing, ensure R-Clip is properly installed and hitch pin nut is installed and tensioned. Replacement parts are available from your Pro Series Distributor.

TOWBALL MOUNT REMOVAL/INSTALLATION

STEP 1

Insert Trailer Ball Mount (TBM) (a) into towbar hitchbox (b), aligning hole in TBM shank (c) with hole in hitchbox (d) (Fig. 1)

STEP 2

Insert Silent Anti-Rattle Hitch Pin (e) through hole in hitchbox and hole in TBM shank (g); ensure the locators are inserted into the notches in the hitchbox (Fig. 2)

STEP 3

Screw Silent Anti-Rattle Hitch Pin Nut (f) onto Smart Pin (g); tighten Smart Pin Nut until finger tight, ensuring TBM is restrained from up and down movement.

STEP 4

Tighten Silent Anti-Rattle Hitch Pin Nut by turning nut a further 1/8th of a turn in the clockwise direction using a 24mm spanner (Fig. 4).

STEP 5

Install Silent Anti-Rattle Hitch Pin R-Clip through the hole that provides best clearance or easiest access. (Fig. 5)

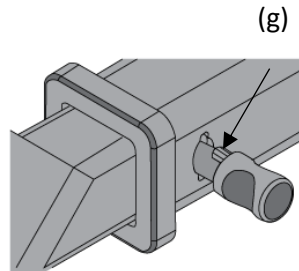
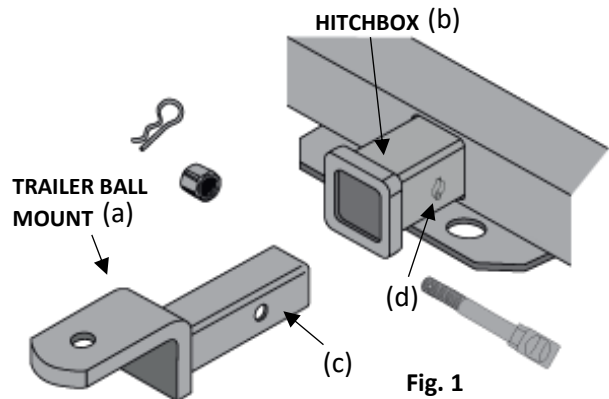

Fig. 2

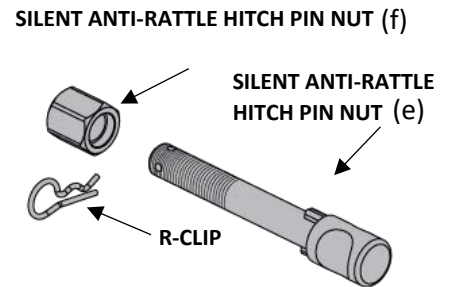

Fig. 3

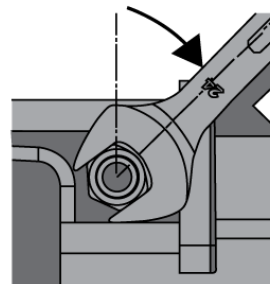

Fig. 4

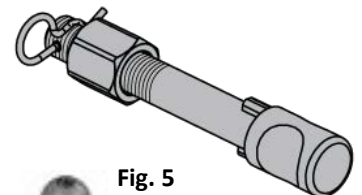

Fig. 5

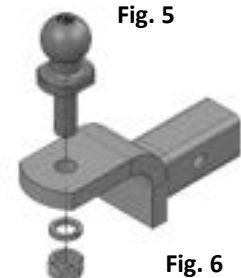

Fig. 6