

TRAILBOSS

Towbar Fitting Instructions To Suit MAZDA 6 2013-0N Part Number QTMA659L Rating 1600/120 kg

PLACE THESE INSTRUCTIONS IN THE VEHICLE'S GLOVEBOX AFTER INSTALLATION IS COMPLETED

WARNING:

1. Do not, drill, cut, weld or otherwise modify the tow bar.
2. If you are using electric welding on a motor vehicle, **always** check that the vehicle is not equipped with electronic engine or instrument management equipment. Failure to do so could **destroy** any onboard computers. If in doubt, check with the vehicle's manufacturer.
3. The high tensile fasteners supplied with this product were used to achieve the specified rating. If replacement is required ensure that fasteners of the same rating & quality are used. Contact an authorised **Trailboss** dealer if further information is required.
4. If TBM is used in inverted position tow ball may make contact with rear tailgate when lowered, which could cause damage.

General:

1. Ensure all hardware items have been included refer to assembly diagram.
2. It is recommended that the instructions are read through and completely understood before making any attempt to fit this product.
3. Be wary of any changes to vehicle designs or other accessories that may conflict with the installation of this product.
4. Before drilling ensure that the area is clear of fuel, electrical & other components.
5. All holes drilled into the body panels shall have all burrs & swarf removed then coated with a suitable rust preventative paint.
6. For vehicles that require the bumper to be cut. Ensure cut out area is in correct position on the vehicle prior to cutting the bumper.
7. The high tensile fasteners supplied with this product were used to achieve the specified rating. If replacement is required ensure that fasteners of the same rating & quality are used. Contact an authorized **Trailboss** dealer if further information is required.
8. Ensure that all hardware is fastened to torque list below check fasteners on regular basis.
9. Tow bar load rating sticker provided with this product shall be conspicuously located on inside rear end of the driver's door. **(See diagram below).**
10. Trailboss recommends that you check your tow ball to ensure that it complies with the Australian standards **AS 4177.2**.
11. **PLEASE NOTE:** It is advised to remove your lug or tbn when not actually towing so as to produce a clear view of the vehicles registration plate if obscured, and to also provide maximum available departure angle
12. Pull Pin must be fit in down position.

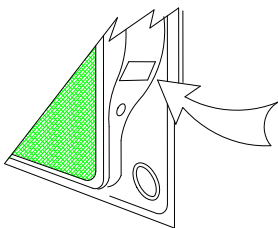

Place load rating sticker
inside driver's door here

FOR TRAILER TOWING PURPOSES ONLY
For towing capacity details please refer to vehicle owner's manual or to the manufacturer. Overloading can void your warranties.

RECOMMENDED ASSEMBLY TORQUE LISTING

Diameter	Grade 8.8 Bolt
M6	9.5 Nm
M8	21.7 Nm
M10	43.4 Nm
M12	77.3Nm
M14	146 Nm
M16	189.8 Nm

Tow bar Maintenance and Care.

Trailboss recommends that bolt torque's, as listed below, are routinely and regularly inspected and checked for correct tension. Replace any worn or defective parts.

We recommended to remove Tow Ball Mounts (TBM's, tongues or lugs) when not being used for any considerable length of time.

So as to avoid injury, when not towing it is suggested that the tongue, Pull Pin and R-clip are removed then stored in a safe, clean and dry place, away from excessive moisture.

Hitch Pull Pins and spring "R" clips are regularly checked for proper installation. Replace any worn or defective parts.

TRAILBOSS

Towbar Fitting Instructions
 To Suit MAZDA 6 2013-0N
 Part Number QTMA659L
 Rating 1600/120 kg

PLACE THESE INSTRUCTIONS IN THE VEHICLE'S GLOVEBOX AFTER INSTALLATION IS COMPLETED

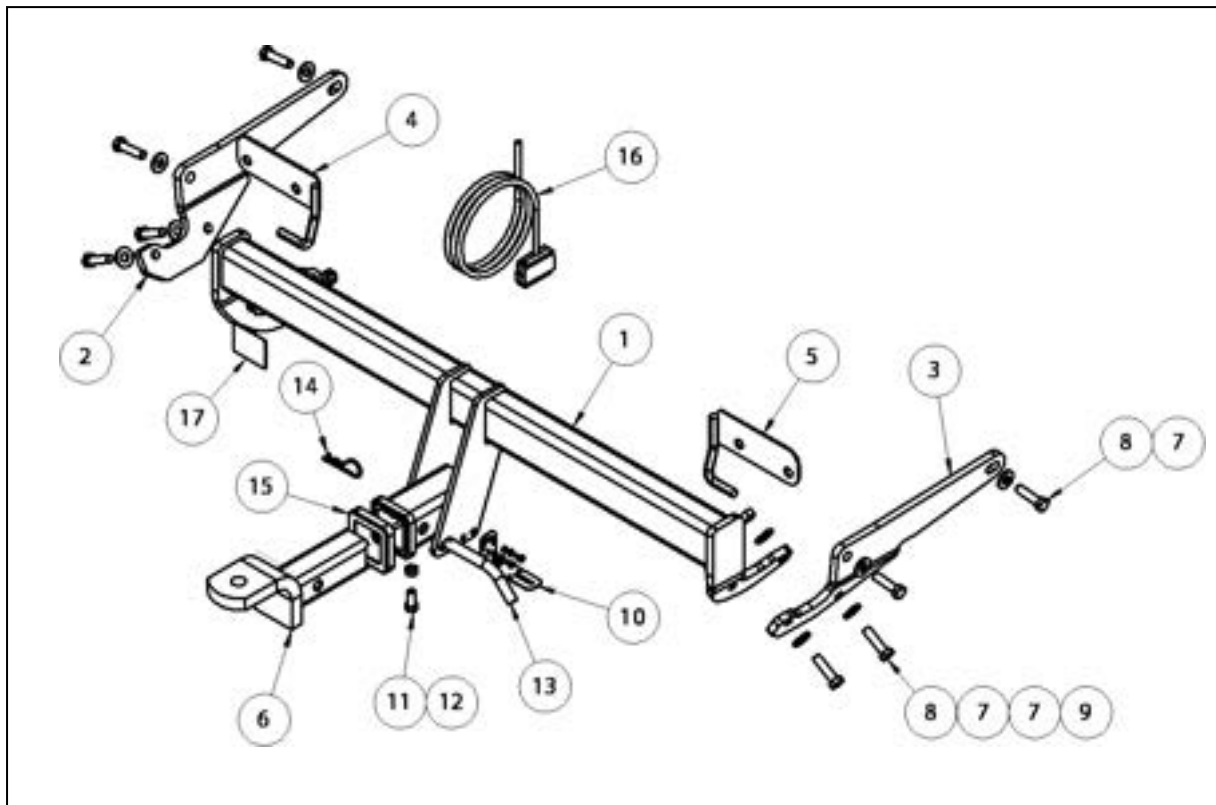

QTY.	DESCRIPTION	ITEM NO.
1	CENTRE SECTION WELDED ASSY	1
1	SIDE ARM LHS	2
1	SIDE ARM -RHS	3
1	LHS EXHAUST HANGER	4
1	RHS EXHAUST HANGER	5
1	TRAILER BALL MOUNT ASSY	6
12	WASHER FLAT M12	7
8	SET SCREW M12x45x1.25P	8
4	HEX NUT M12x1.25 PC8	9
1	UNIVERSAL PLUG BRACKET KIT	10
1	BOLT M10-1.50 X25	11
1	HEX NUT M10x1.5	12
1	PULL PIN	13
1	R CLIP	14
1	HITCH BOX COLLAR COVER	15
1	WIRING LOOM	16
1	ACRYLIC COMPLIANCE PLATE	17



Towbar Fitting Instructions
To Suit **MAZDA 6 2013-0N**
Part Number **QTMA659L**
Rating **1600/120 kg**

PLACE THESE INSTRUCTIONS IN THE VEHICLE'S GLOVEBOX AFTER INSTALLATION IS COMPLETED

INSTRUCTION:

1. Remove 2x Screws and 1x push rivet inside rear wheel arch.
Repeat for other side.
2. On the underside of Bumper to back panel, remove 2x push Rivets securing bumper to back panel.
3. Open Boot, remove inner carpet and polystyrene inserts. Remove 4x push rivets (2 each side) attaching inner plastic trim to rearwards face of inside of boot cavity.
4. Unclip plastic trim around locking latch.
5. Remove inner plastic trim by lifting upwards.
6. Remove 2x small plastic push rivets in newly exposed area securing inside carpet to chassis rail.
7. From underneath loosened carpet, remove 3x Nuts from the rear of tail light and remove light assembly.
8. In newly exposed cavities from tail lights, remove 1x Screw each side.
On rear face of bumper, remove cover cap and remove screw securing bumper underneath.
9. Remove 2x Screws from underside of Bumper on both sides.
Unclip the sides of the Bumper by pulling firmly and remove Bumper.
10. Disconnect both exhaust hanger rubbers from rear impact beam.
11. Remove rear impact beam from vehicle by removing 8x nuts securing beam to chassis.
Discard beam after removal.
12. Secure supplied exhaust hanger plates to chassis using existing bolts, mounting to lower studs.
Tighten Bolts to recommended torques on page 1.
Attach exhaust hanger rubbers to the hooks on each newly mounted plate.
13. Loosely bolt Side Arms to Chassis Rail using 2x M12 Bolts & Washers on both sides.
14. Mount Towbar centre section to chassis arms, ensuring that Bolts are directed inward as to allow for bumper clearance. Complete with 2 Washers and 1 Nut per Bolt.
15. Torque all Bolts to recommended torques on page 2.
16. Cut out a section of the Bumper under tray approximately 175mm x 90mm.
Re-fit bumper and all other components following steps 1 – 9 in reverse order.



Wiring Loom Fitting Instructions
To Suit Mazda 6
Part Number 100968-WL

Wiring Loom Installation Instructions

Mazda 6
Part No: 100968-WL
ECU Required: 04826

Tail Harness Length Required: 1800mm

Wiring Loom Installation Time: Approx 45 Mins

Wiring Loom Fitting Instructions To Suit Mazda 6 Part Number 100968-WL

1. In the luggage compartment, remove the parcel shelf, and the floor cover carpet.
2. Remove the two foam tool trays.
3. Remove the rear luggage compartment trim by pulling in an upwards direction.
4. Remove both the LHS & RHS luggage compartment access cover.
5. On the RHS luggage compartment, remove the tool tray.
6. On the LHS luggage compartment, remove the two fasteners and remove the tool tray.
7. On the rear of the LHS luggage compartment, remove the cargo hook by removing the bolt.
8. Remove the two clips securing the LHS luggage compartment trim and the one screw securing the cargo hook.
9. On the LHS upper plastic trim of the luggage compartment, remove the three screws.
10. Dislodge the LHS luggage compartment trim.
11. On the LHS of the rear passenger, remove the seat trim.
12. Remove the LHS door trim.
13. Dislodge the LHS 'B' pillar trim.
14. On the LHS of the front passenger, remove the door trim.
15. Remove the LHS of the kick panel access cover.
16. On the LHS rear quarter panel of the luggage compartment, drill a Ø30mm hole (1) next to the existing vehicle grommet.
17. File any rough or sharp edges and spray with rust inhibitor.



Wiring Loom Fitting Instructions To Suit Mazda 6 Part Number 100968-WL

18. On the LHS of the luggage compartment, disconnect both the 2-way and 3-way tail light connectors (1) and connect the trailer patch (2) in between.
19. Following the table below, connect the ezy-tap (3) to the corresponding BLACK/WHITE wire (4), then connect the terminal (5) to the ezy-tap (3).

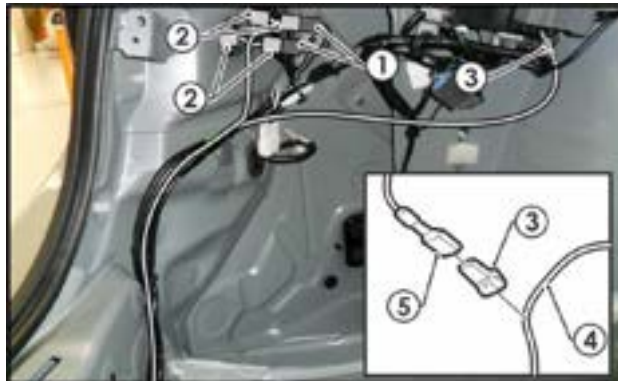

Function	Trailer Patch	Vehicle Connector
REVERSE	BLACK / WHITE	WHITE / BLACK

20. Connect the trailer patch 12-way connector to the ECU.
21. Apply the double sided tape to the ECU and adhere it onto the sheet metal on a suitable location.
22. Secure the trailer patch ground ring terminal to the vehicle grounding point.
23. Route the trailer patch towards the RHS of the vehicle.
24. Disconnect the tail light connectors and connect the trailer patch in between.
25. Route the 'ORANGE' power wire towards the front of the vehicle past the 'B' pillar trim.
26. Continue routing the 'ORANGE' power wire towards LHS front passenger kick panel trim.

Wiring Loom Fitting Instructions To Suit Mazda 6 Part Number 100968-WL

27. Inside the fuse panel, locate the vacant slot as shown (1).
28. Insert the supplied 20-Amp fuse (2) into the upper slots of the add-a-fuse (3).
29. Plug the add-a-fuse (3) into the vacant fuse slot on the fuse panel.
30. Connect the power patch 1-way connector (4) into the add-a-fuse harness mating connector (5).

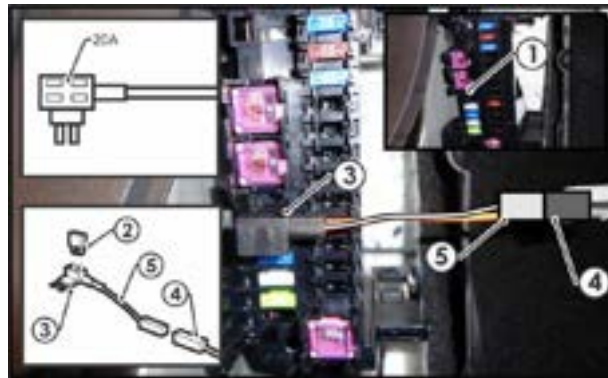

31. Mount the trailer socket to the towbar mounting bracket using M4 fasteners (not supplied).
32. Route the tail harness (tail length 1800mm) across the towbar towards the LHS of the vehicle and up through the previously drilled out hole.
33. Ensure the tail harness grommet is seated correctly and secure in place using a cable tie (not supplied).
34. Connect the tail harness 8-way connector to the trailer patch mating 8-way connector.
35. Test the trailer harness function using a Light Board or multimeter.
36. Secure all Harnesses using cables ties (not supplied).
37. Re-fit all removed parts and secure all fasteners, ensuring there are no squeaks or rattles.
38. Place the instructions in the glove box after fitment.