



TOWBAR INSTALLATION INSTRUCTIONS

PART NUMBER QTMA667L

MAZDA MX-30 DR, 5D SUV,

PRODUCT DETAILS:

| | | | | |
|-------------------------------|----------|---------------------------|-----|----|
| Part Number: | QTMA667L | Maximum Towing Braked: | 800 | kg |
| ECU Number: | 04843 | Maximum Towing Unbraked: | 600 | kg |
| Tail Harness Length Required: | 1800 mm | Maximum Static Ball Load: | 80 | kg |
| TBM/Lug Part Number: | 21236 | | | |

FITTING DETAILS:

| | | | |
|---------------------------|-----------|--------------------|-----|
| Towbar Installation Time: | 60 Mins. | RPA Disable/Other: | YES |
| Total Installation Time: | 100 Mins. | | |
| Bumper Cut Required: | Yes | | |

Note:

- RPA disable automatically detected using any 1800mm tail.
- Specific RPA tail not required.

TRAILBOSS RECOMMENDS THAT INSTRUCTIONS ARE READ AND UNDERSTOOD COMPLETELY PRIOR TO FITMENT.

BEFORE YOU START:

Check all hardware items have been included refer to assembly diagram.
Please ensure this towbar is only fitted to vehicle models as per Trailboss application guide.

Bumper Cuts

Vehicle and bumper variations can and do occur during vehicle manufacture after initial towbar design. Fitment of towbar to vehicle and accuracy of bumper cut must be assessed prior to any bumper modifications made. Incorrect bumper cuts are not covered under Trailboss warranty.

NOTE: Bumper cuts need to be approached with care, refer to notes below.

- Bumper centreline – where the centreline of the bumper needs to be determined, the installer must assess centre point by measurement of bumper width or determining two symmetrical reference points to give centreline.
- Bumper edge – To assist with accurate bumper cut measurement, reference to the start of the bumper edge is now being commonly used.
 - Measure from bottom edge along bumper and around corner to the 70 mm point (Figure 1).
 - Do not measure from visible bumper front of corner, upwards (Figure 2).

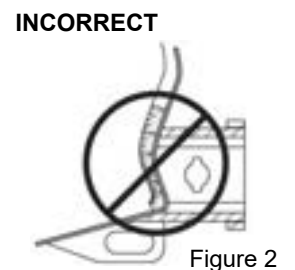
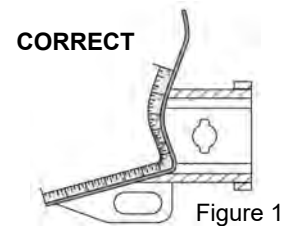

Drilling

- For any required drilling during installation, ensure that the area is clear of fuel, electrical & other components that may be damaged.
- All holes drilled into metal body panels shall have all burrs & swarf removed then coated with a suitable rust preventative paint.

Bolts/Fasteners

- Ensure that all hardware is fastened to correct torque as specified in this fitting instruction.
- All fasteners supplied with this product are used to achieve a specified clamp loading. If replacement is required ensure that fasteners of the same grade and class are used.

NOTE: Achieving correct torque is critical to proper installation and responsibility of the installer. Towbar failures attributed to tension issues from over tightening or under tightening are not covered by Trailboss warranty.

Product Labels

- a. Towbar load rating sticker provided with this product shall be conspicuously located on inside rear end of the driver's door.

WARNING:

Do not, drill, cut, weld or otherwise modify the towbar.

FOR TOWING PURPOSES ONLY - This towbar is designed and tested by Trailboss to adhere to ADR 62/02 which provides only for the expected load demands of towing.

i TOWBAR ASSEMBLY DIAGRAM

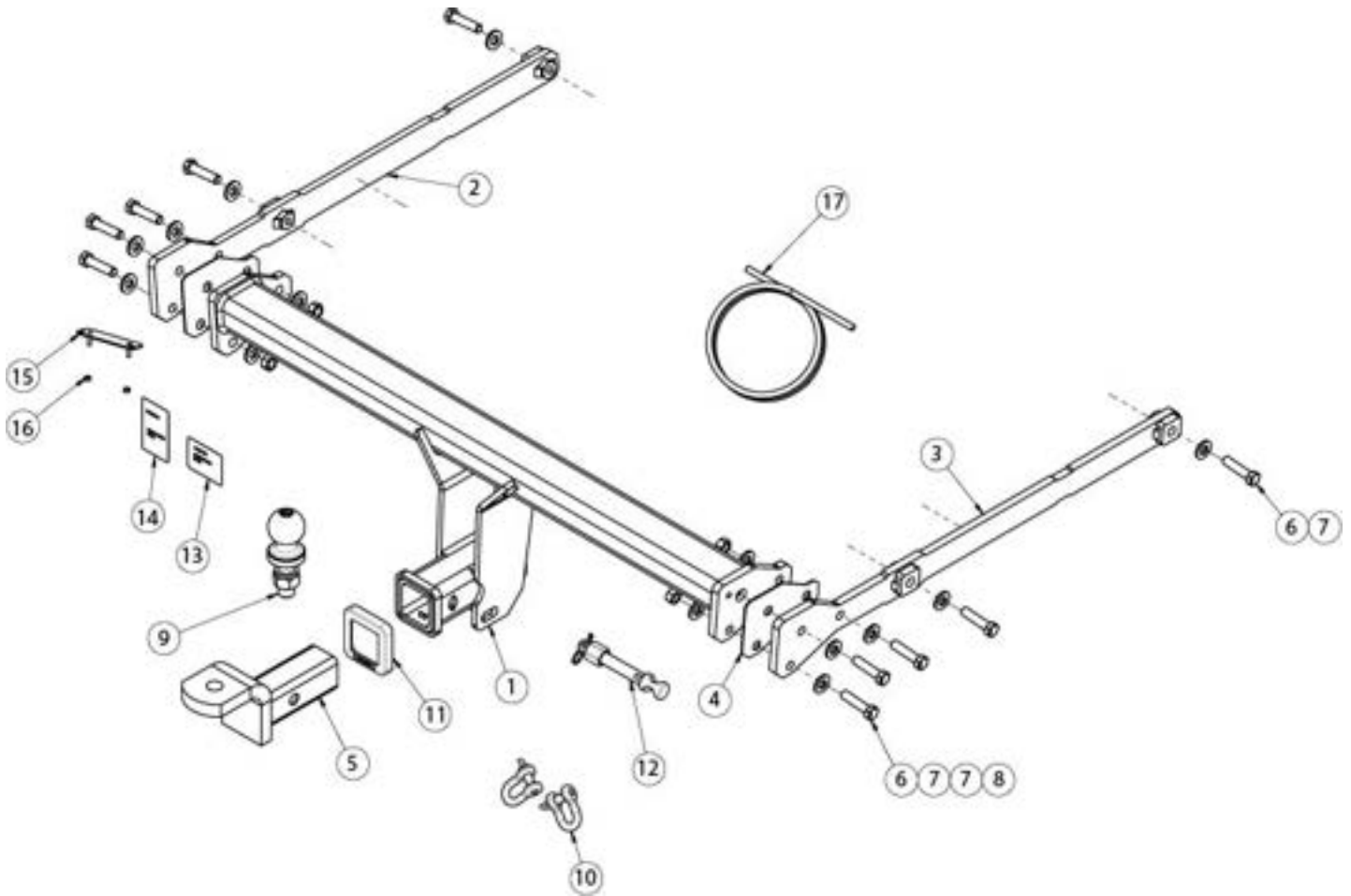

| ITEM | DESCRIPTION | QTY |
|------|-----------------------------|-----|
| 1 | MAZDA MX-30 WELDED ASSEMBLY | 1 |
| 2 | SIDE ARM ASSY LHS | 1 |
| 3 | SIDE ARM ASSY RHS | 1 |
| 4 | SPACER PLATE | 2 |
| 5 | TRAILER BALL MOUNT | 1 |
| 6 | BOLT HEX HD M12x50x1.75P | 10 |
| 7 | WASHER PLAIN 1/2" | 14 |
| 8 | NUT HEX HD M12x1.75P | 4 |
| 9 | TOWBALL 50mm | 1 |

| ITEM | DESCRIPTION | QTY |
|------|------------------------|-----|
| 10 | "D" SHACKLE 10mm | 2 |
| 11 | HITCH BOX COLLAR COVER | 1 |
| 12 | SMART PN SILVER | 1 |
| 13 | COMPLIANCE LABEL | 1 |
| 14 | LOAD RATING LABEL | 1 |
| 15 | PLUG BRACKET | 1 |
| 16 | NUT NYLOC HEX M4x0.7P | 2 |
| 17 | WIRE LOOM | 1 |

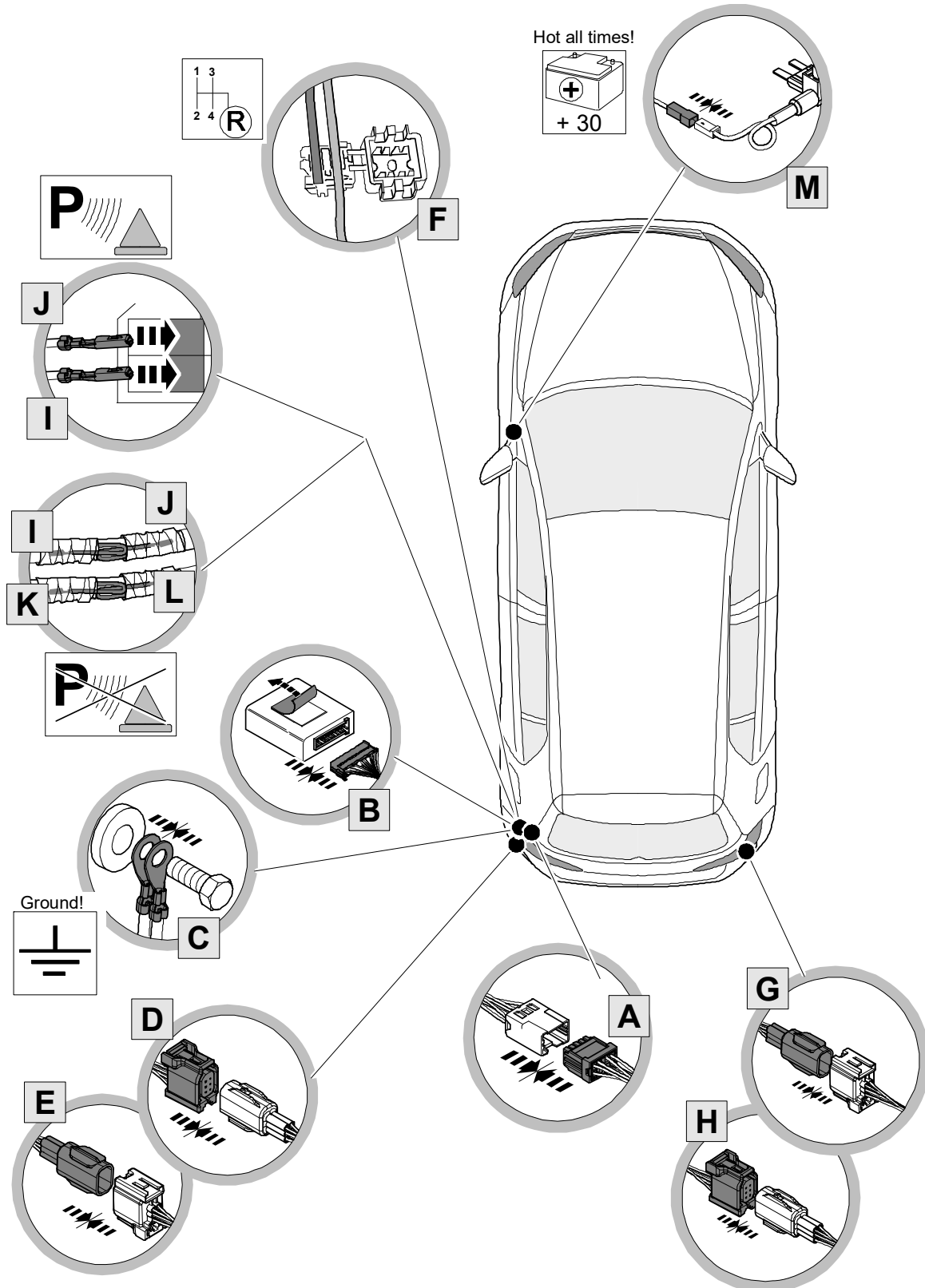

i WIRING ASSEMBLY DIAGRAM

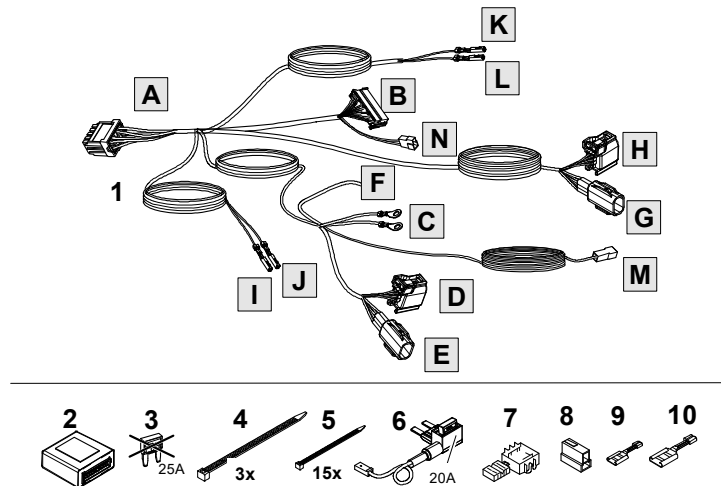

| ITEM | DESCRIPTION | QTY |
|------|----------------------|-----|
| 1 | Main wire harness | 1 |
| 2 | ECU (04843) | 1 |
| 3 | Fuse 25A | 1 |
| 4 | TIE STRAPS | 3 |
| 5 | TIE STRAPS | 15 |
| 6 | Fuse Adaptor 20A | 1 |
| 7 | Splice | 1 |
| 8 | HOUSING 082 NT 6.3MM | 1 |
| 9 | CONTACT 6,30MM/1,00 | 1 |
| 10 | CONTACT 6,30MM/2,50 | 1 |

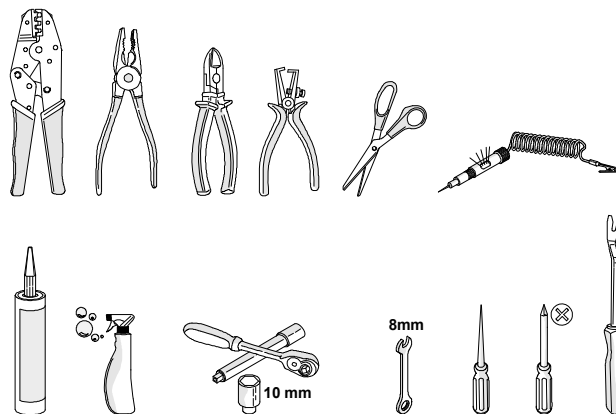

-
1. Release the rear lift gate to expose the boot cabin. Remove the 3 x Tail light covers.

Repeat for the other side.

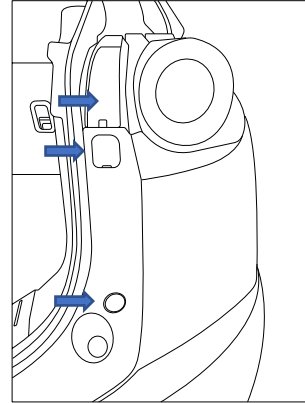

-
2. Remove the 2x Screws from taillight and 2 x Screws from the bumper.

Repeat for the other side.

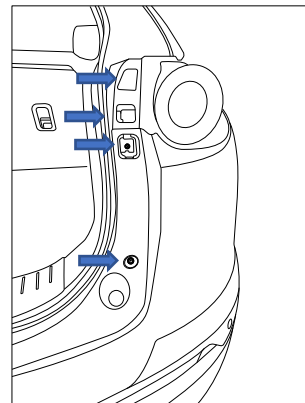

-
3. Remove the interior boot floor trim panel.

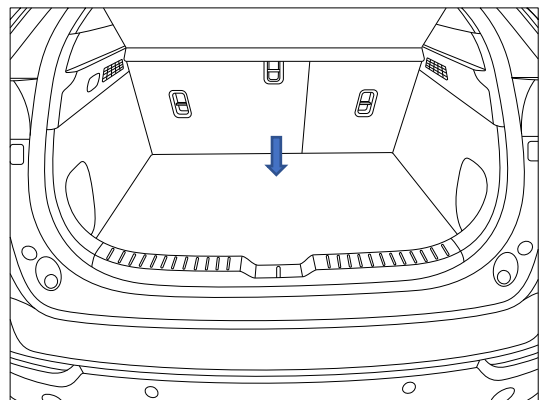

-
4. Remove parcel shelf and foam inserts surrounding the spare wheel and rear boot trim Panel.

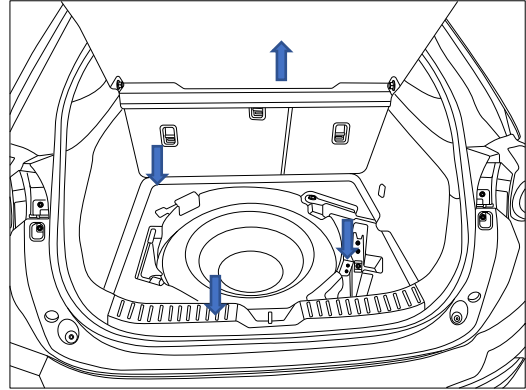

-
5. Remove 2 x Scrivets retaining the side trim panel to the rear of the vehicle.

Repeat for other side.

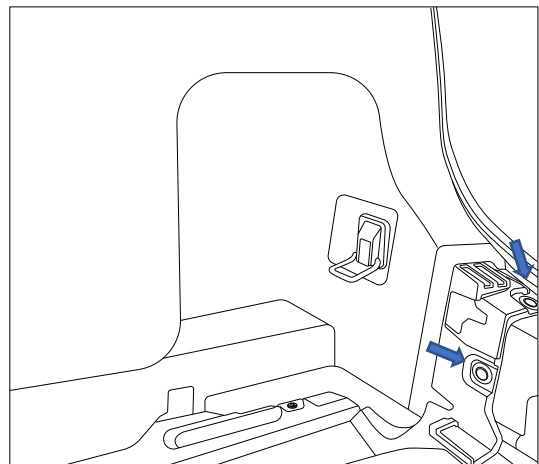

-
6. Remove 2 x side trim panel tie downs by flipping the screw cover down and remove 1x screw per tie down.

Repeat for other side.

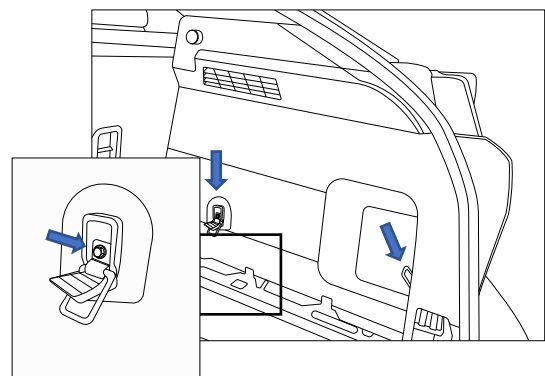

-
7. Lay rear seats forward and remove the Upper Side Trim Panel.

Disconnect the rear boot light when removing the LHS trim.

Repeat for other side.

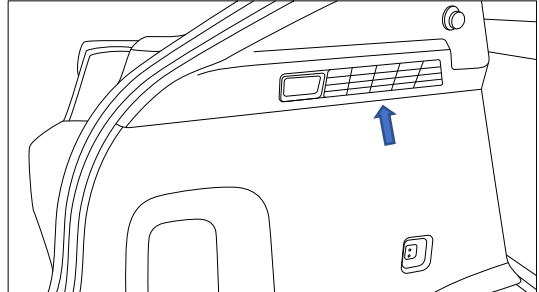

-
8. Remove Scrivet retaining side trim panel.

Repeat for other side.

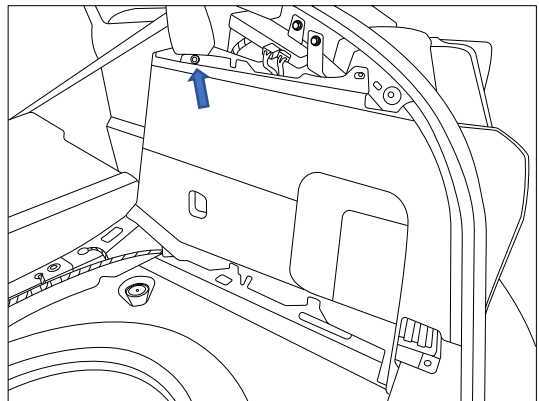

-
9. Remove LHS sill trim.
10. Peel the weather strip away from the sheetmetal in the kick trim area and remove the LHS kick trim.

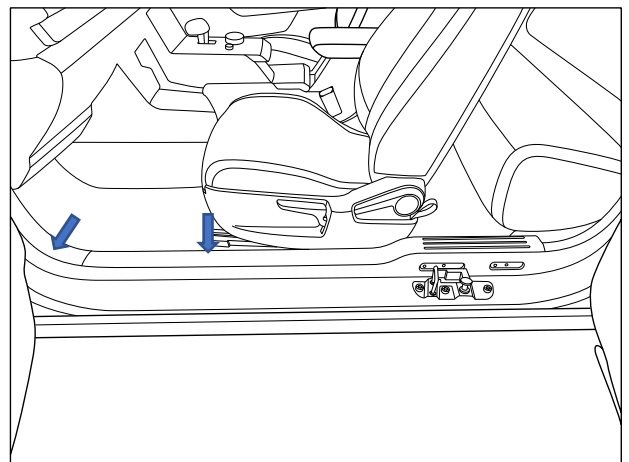

-
11. In the rear gently fold the side trim panels into the center of vehicle as shown.

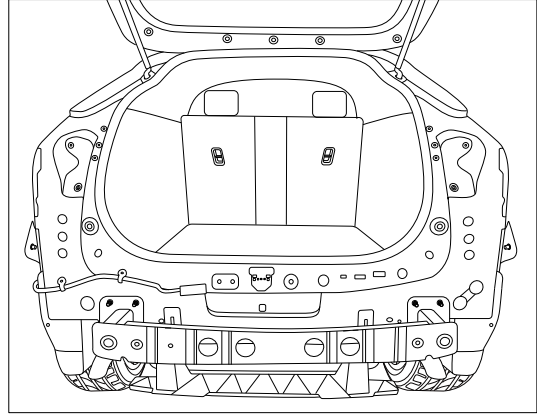

-
12. Remove 1 x scrivet and remove the plastic trim covering the wiring on the rear corner by rotating and sliding the trim piece towards the front of the vehicle.

Repeat for other side.

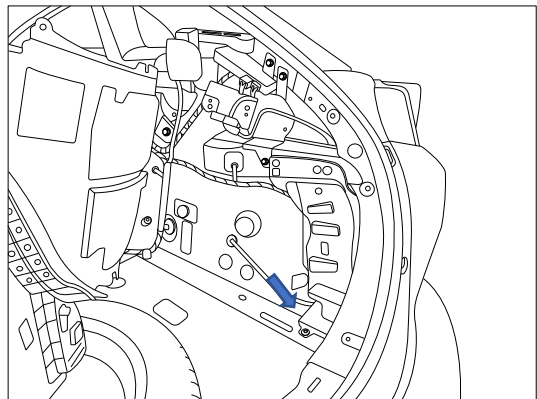

-
13. Remove the nut connecting the tail lamp to the vehicle. Disconnect the rear taillight wiring harness connectors, unplug the grommet feeding the wiring through the grommet hole and remove the taillight from the vehicle.

Repeat for other side.

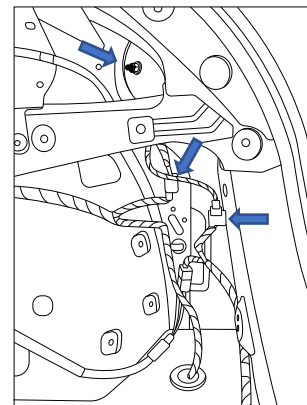

-
14. Remove 2 x Scrivets from underneath rear bumper.

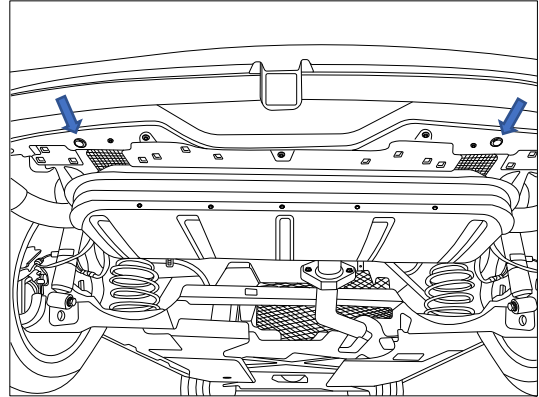

-
15. Remove 3 x Screivets from Wheel Arch liner.

Repeat for other side.

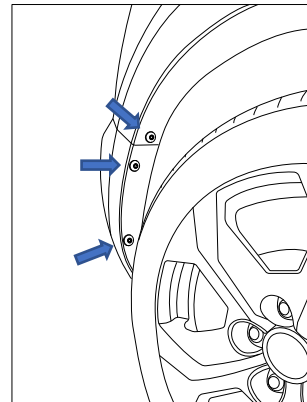

-
16. Remove 2 x Screws from between rear bumper and wheel Arch liner.

Repeat for other side.

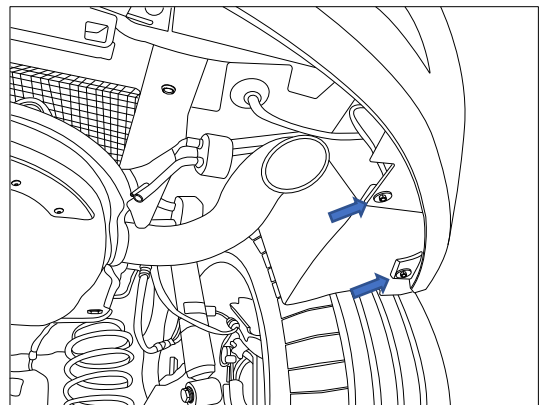

-
17. Untrim Peel back the side guard mouldings to expose and remove the 1 x Scrivet and 1 x Screw.

Repeat for other side.

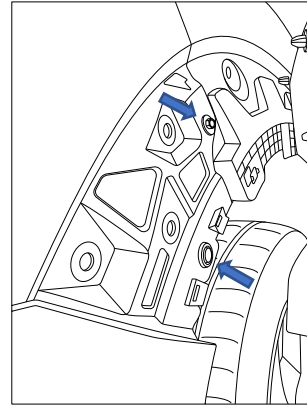

-
18. Carefully remove the rear bumper.
Store safely to avoid damage to the rear bumper.

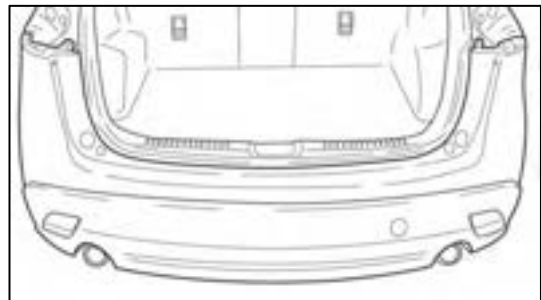

-
19. Remove and discard the impact beam by removing the 8 x M12 hex nuts.

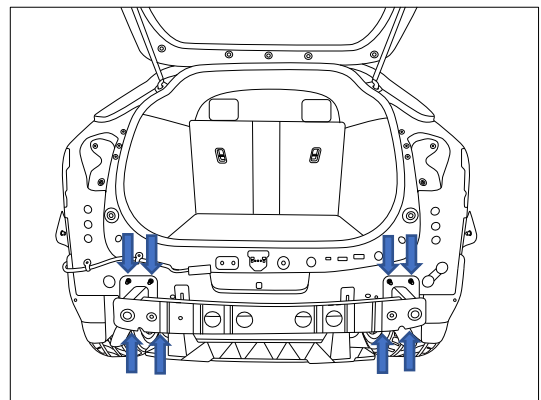

20. Remove 2 x Screws and remove the rear bumper attachment bracket.

Do not discard as this will need to be cutout and reinstalled to vehicle. See step 23.

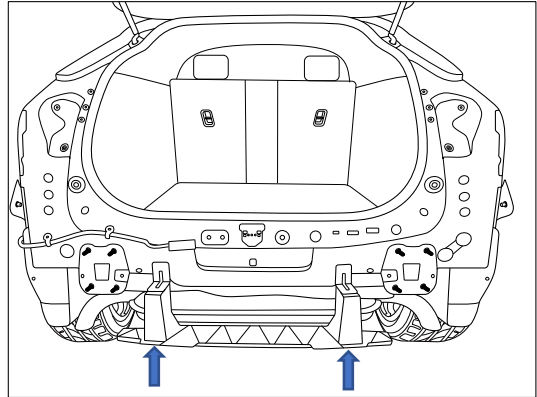

21. Insert the side arm into the chasis rail, peel off the tape covering the holes in the chasis rails and loosely insert 2x Bolts and 2 x Washers through chasis holes in the side arm.

Repeat for other side.



Carefully selecting the side arm for the corresponding side. The weld nuts on the side arm must face toward the center line of the vehicle.

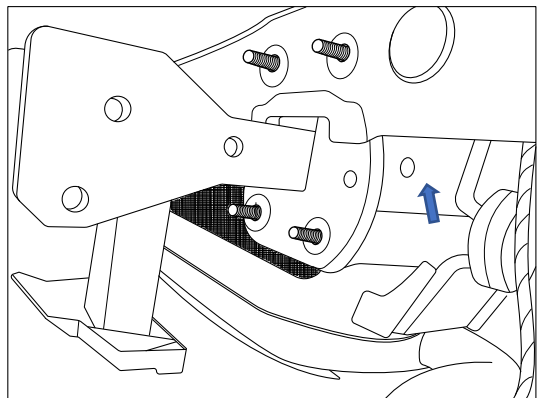

22. Place the spacer and cross bar between the side arms, Insert 3x bolts, 3x washers, 2x nuts.

Repeat for other side.

Torque all M12 bolts = 109Nm

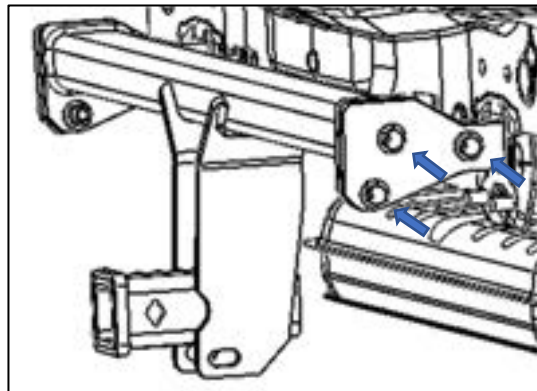

23. Place masking tape on the rear bumper attachment bracket. Mark and cut out an area as shown to clear the hitch box.

Remove all swarf and rough edges.

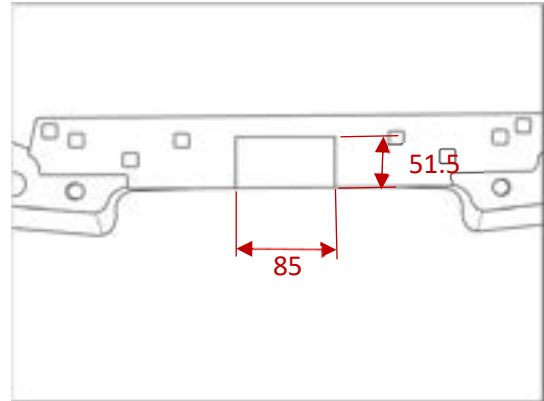

24. Remove the 4 x Screws retaining the rear bumper trim panel and discard.

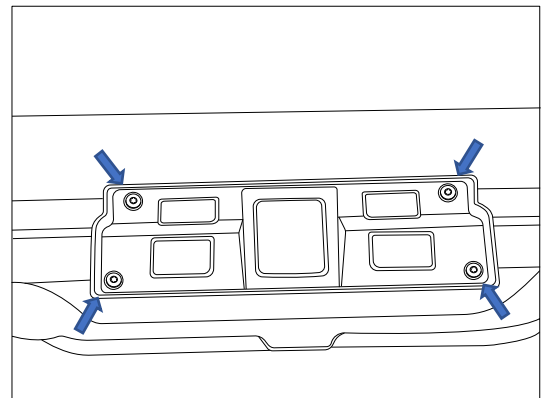

25. Place masking tape on the bumper outer skin. At the center of the rear bumper measure 75mm across the top follow the angle of the bumper trim edge down to the bottom of the rear bumper as shown. Approx. 100mm across the bottom edge. Mark and cut out an area as shown to clear the hitch box.

Remove all swarf and rough edges.

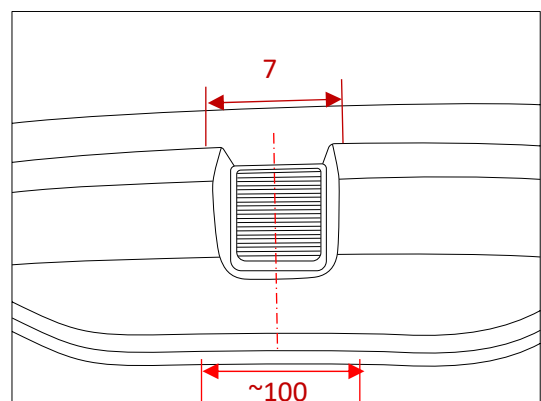

26. For plug bracket.

At an appropriate position on the bumper, mark out and drill 2x $\varnothing 5\text{mm}$ holes 69mm apart on bumper skin to support plug bracket.

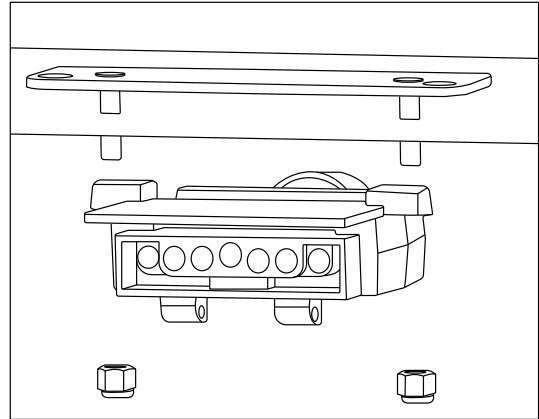

IMPORTANT

Due to possible vehicle variations, always confirm any noted vehicle colour wires with a multi-meter to ensure the correct function is identified before soldering or scotch locking. For vehicle wires denoted with two colours (example; RED/GREEN) the first colour will always be the main wire colour while the second colour is the thinner trace colour on the wire.

27. Locate and remove vehicle blanking grommet.

28. Using a step drill, drill out the hole to $\varnothing 30\text{mm}$.

29. Feed the 1800mm tail connector through the previously drilled hole, slide the grommet to desired position allowing enough length to mount the trailer plug.

30. Secure the grommet in place using a cable tie.

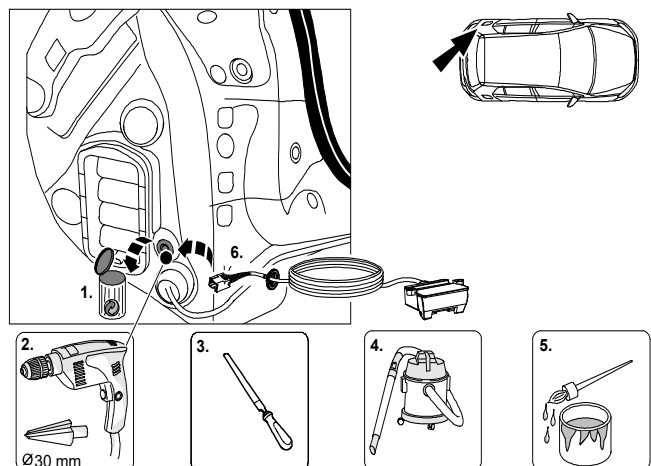

31. Connect the trailer patch ring terminals (C) to factory ground point.

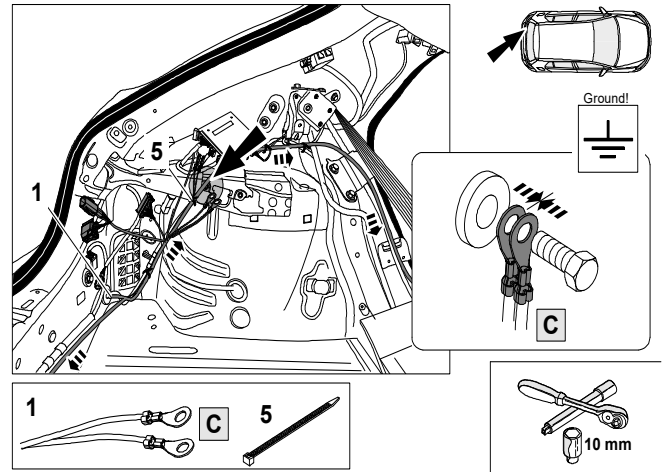

32. Connect the trailer patch 18-way connector (B) to ECU 04843 (2).

33. Remove the adhesive tape protector off the ECU and place the ECU on a flat surface.

34. Press for at least 20-30 seconds to ensure proper adhesion.

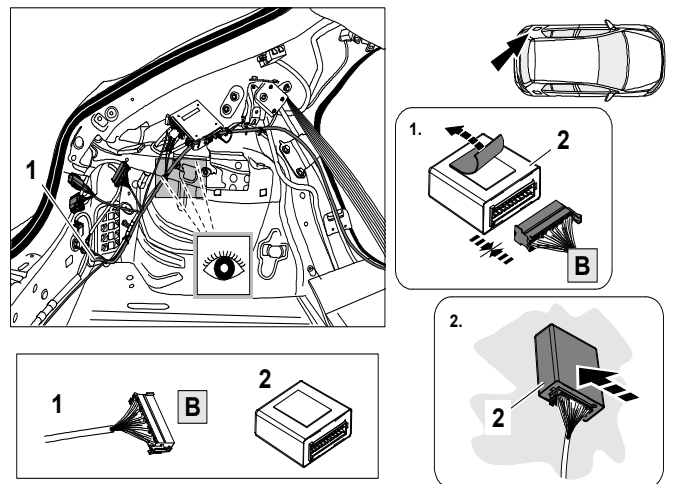

35. Patch in the LHS trailer patch connectors (E) and (D).

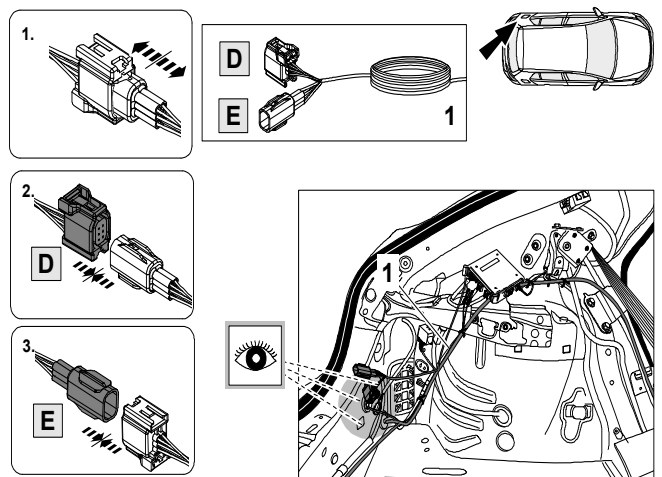

⚠ Note: This step is only for connecting Reverse only if this is not required tape the Black/Yellow (F) trailer patch wire back to harness.

36. Remove the tape on the rear loom to expose a purple wire.
37. Use splice for connection of 2 wires
38. Insert vehicle Purple wire into splice tap
39. Insert trailer patch Black/Yellow (F) wire into splice tap.
40. Close splice and use pliers to fully lock splice.

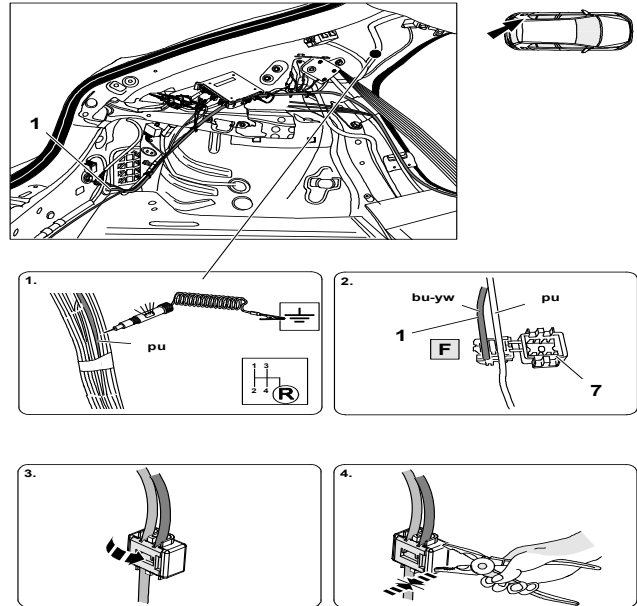

RPA Steps.

41. Locate vehicle rear BCM located on the LHS wheel arch.
 42. Remove the 16-way connector.
 43. Using jewellers screw driver open the secondary lock.
- Insert trailer patch PDC wires Black/Green (I) and White (J) into the cavity as indicated

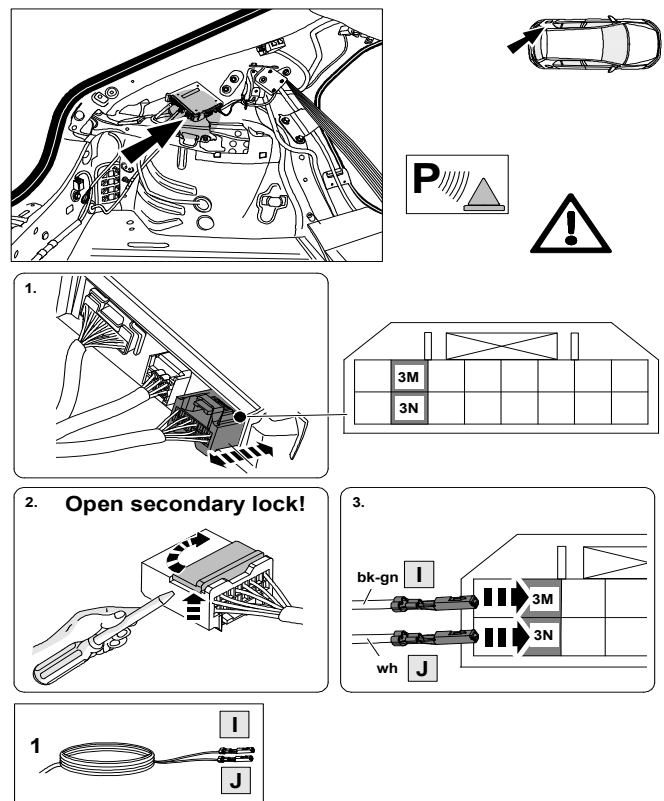

- 44. Close secondary lock.
- 45. Insert connector back to the unit.
- 46. Locate the trailer patch wires Black/Blue (k) and White (L) and tape back to harness.

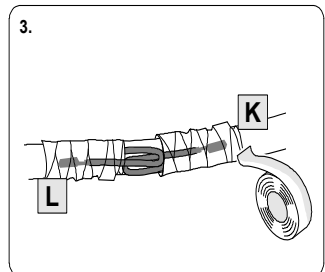
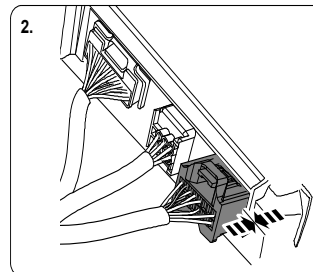
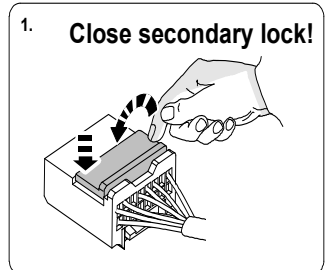
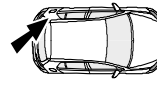

K bk-bu
L wh

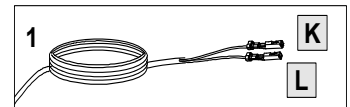

- 47. Patch in the LHS trailer patch connectors (G) and (H).

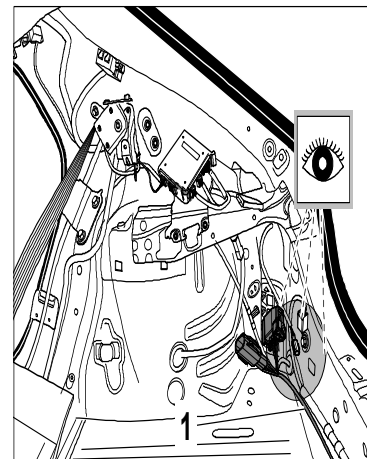
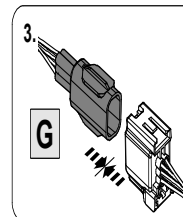
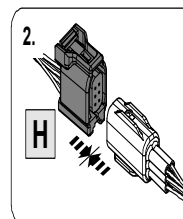
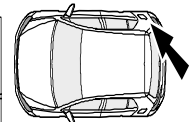
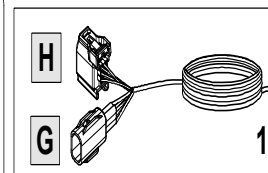
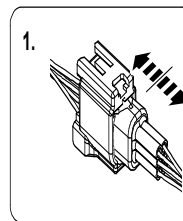

48. Route trailer patch 1-way power connector (M) towards the Front passer footwell fuse box.

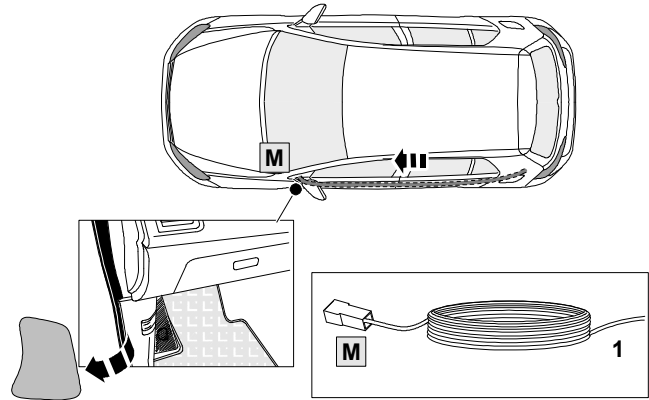

49. Connect add-a fuse adaptor (6) to main harness connector (M).

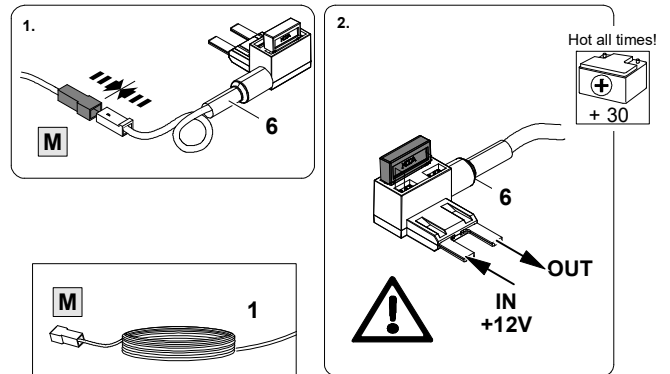

50. Connect Fuse adaptor (6) to position F7 ensure the orientation has wire facing downwards.

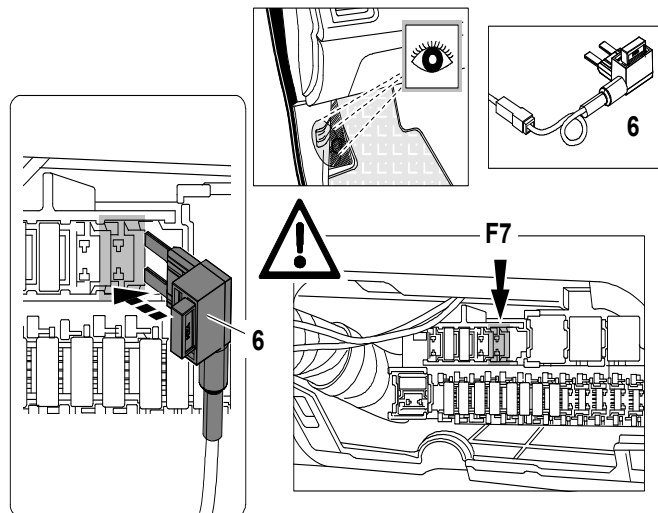

51. Secure all harness using cables ties.
52. Re-fit all removed parts in in the following steps 1-18, and 20 in reverse ensure no rattle and squeaks.
53. Test the trailer wiring harness function using a trailer test board.

RPA and SCBS-R (Smart City Brake Support Reverse) will disable when trailer is plugged in. Below is the test method and what will appear on the dash.

54. Place fiitng instructions in glovebox after fitment.

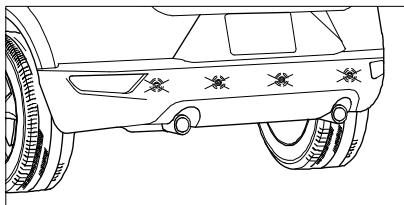
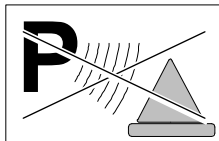
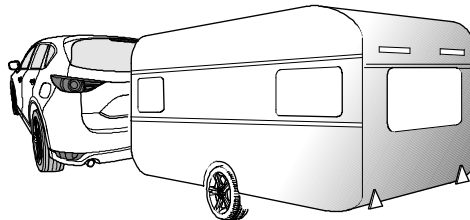
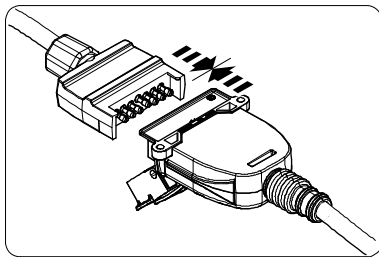

The PDC or SCBS-R system is not active while the parking brake is engaged.



In order to test automatic PDC and SCBS-R deactivation while stationary, plug in a trailer light tester or trailer and ensure the parking brake is disengaged. A deactivation message will be displayed as shown.

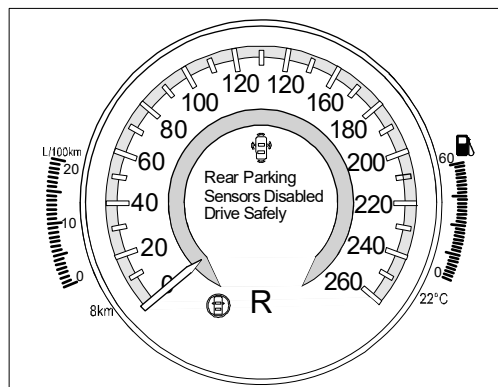



CUSTOMER INFORMATION

PLACE THESE INSTRUCTIONS IN THE VEHICLE'S GLOVEBOX AFTER INSTALLATION

THANK YOU FOR PURCHASING TRAILBOSS. WITH CORRECT MAINTENANCE AND CARE THIS PRODUCT WILL PROVIDE A LIFETIME OF TROUBLE-FREE OPERATION.

TOWBAR MAINTENANCE AND CARE:

1. Trailboss recommend that the towbar LUG or TBM (Trailer Ball Mount) Pull Pin and R-clip are removed and stored when not in use. Removal of LUG or TBM (Trailer Ball Mount) is advisable when not in use to assist with any of the following.
 - Ensure rear number plate is not obscured.
 - Allow maximum available departure angle and prevent any potential interference.
 - Prevent possible interference with vehicles reverse sensors or camera detecting a tow ball mount as an obstruction during reversing.
 - Removes towball mount as an obstruction for when moving around the rear of the vehicle.
2. Trailboss recommends routine inspection of your towbar to ensure trouble free towing.
 - Bolt security and tension should be regularly inspected and checked for correct tension. Replace any worn or defective parts with suitable grade & class fasteners. Inspection should be requested to coincide with vehicle major services.
3. It is the owner's responsibility to ensure towing and down ball weight capacities of the towing vehicle are not exceeded.
 - Towing and down ball weights allowable may differ according to model variations. Please refer to owner's manual or vehicle dealer to confirm exact rating for your vehicle model variant.
 - It is not uncommon for the vehicle tow rating to differ from the towbar rating. When this occurs, the lesser rating must be adhered to.
 - For vehicles fitted with enhanced vehicle functions that may be altered/changed when towing i.e Trailer sway mitigation, blind spot detection, adaptive cruise control etc. Please consult owner's manual to understand changes enabled when towing and after towing.

WARRANTY INFORMATION:

Trailboss Towbars are covered by a Lifetime Warranty.

Our goods come with guarantees that cannot be excluded under the Australian Consumer Law. You are entitled to a replacement or refund for a major failure and for compensation for any other reasonably foreseeable loss or damage. You are also entitled to have the goods repaired or replaced if the goods fail to be of acceptable quality and the failure does not amount to a major failure.

For further details please contact customer service on 1800 812 017.

PRO SERIES SILENT ANTI-RATTLE HITCH PIN

Your Trailboss towbar is equipped with a Pro Series Silent Anti-Rattle Hitch Pin technology to help reduce towbar tongue rattle in most driving conditions. Please ensure below instructions are understood and routine maintenance is carried out to ensure best towing experience.

Regularly inspect for wear and check the tightness of the Silent Anti-Rattle Hitch Pin. Follow instructions below to re-tighten the nut as necessary when movement and noise in the tow ball mount is noted.

- Before towing, ensure R-Clip is properly installed and hitch pin nut is installed and tensioned. Replacement parts are available from your Pro Series Distributor.

TOWBALL MOUNT REMOVAL/INSTALLATION

STEP 1

Insert Trailer Ball Mount (TBM) (a) into towbar hitchbox (b), aligning hole in TBM shank (c) with hole in hitchbox (d) (Fig. 1)

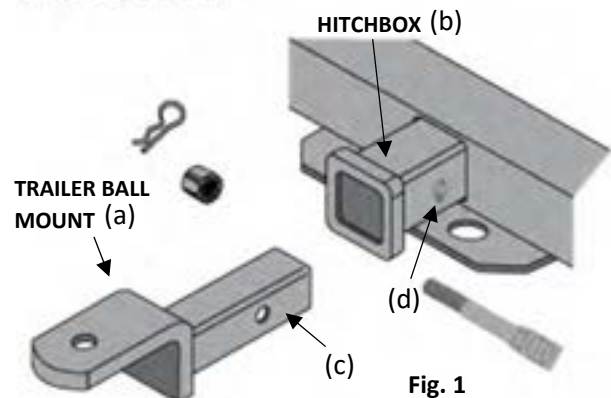

STEP 2

Insert Silent Anti-Rattle Hitch Pin (e) through hole in hitchbox and hole in TBM shank (g); ensure the locators are inserted into the notches in the hitchbox (Fig. 2)

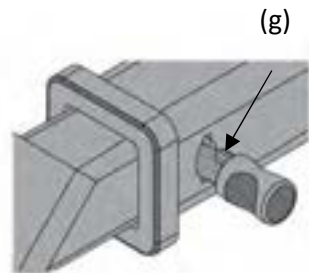

Fig. 2

STEP 3

Screw Silent Anti-Rattle Hitch Pin Nut (f) onto Smart Pin (g); tighten Smart Pin Nut until finger tight, ensuring TBM is restrained from up and down movement.

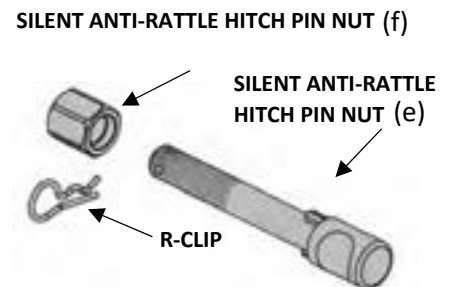

Fig. 3

STEP 4

Tighten Silent Anti-Rattle Hitch Pin Nut by turning nut a further 1/8th of a turn in the clockwise direction using a 24mm spanner (Fig. 4).

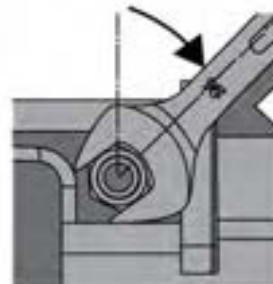

Fig. 4

STEP 5

Install Silent Anti-Rattle Hitch Pin R-Clip through the hole that provides best clearance or easiest access. (Fig. 5)

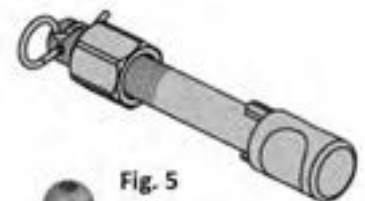

Fig. 5

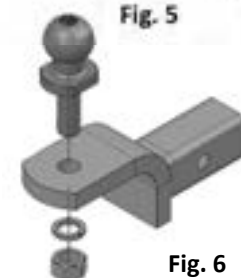

Fig. 6