

**PRODUCT DETAILS:**

---

<b>Part Number:</b>	QTMA668L	<b>Maximum Towing Braked:</b>	2000	kg
<b>ECU Number:</b>	04836	<b>Maximum Towing Unbraked:</b>	750	kg
<b>Tail Harness Length Required:</b>	1800 mm	<b>Maximum Static Ball Load:</b>	200	kg
<b>TBM/Lug Part Number:</b>	21196			

---

**FITTING DETAILS:**

---

<b>Towbar Installation Time:</b>	120 Mins.	<b>RPA Disable/Other:</b>	YES
<b>Total Installation Time:</b>	150 Mins.		
<b>Bumper Cut Required:</b>	Yes		

---

**Note:**

- Use WLT025 to disable RPA & Smart City Stop.

### TRAILBOSS RECOMMENDS THAT INSTRUCTIONS ARE READ AND UNDERSTOOD COMPLETELY PRIOR TO FITMENT.

#### BEFORE YOU START:

Check all hardware items have been included refer to assembly diagram.  
Please ensure this towbar is only fitted to vehicle models as per Trailboss application guide.

#### Bumper Cuts

Vehicle and bumper variations can and do occur during vehicle manufacture after initial towbar design. Fitment of towbar to vehicle and accuracy of bumper cut must be assessed prior to any bumper modifications made. Incorrect bumper cuts are not covered under Trailboss warranty.

**NOTE: Bumper cuts need to be approached with care, refer to notes below.**

- Bumper centreline – where the centreline of the bumper needs to be determined, the installer must assess centre point by measurement of bumper width or determining two symmetrical reference points to give centreline.
- Bumper edge – To assist with accurate bumper cut measurement, reference to the start of the bumper edge is now being commonly used.
  - Measure from bottom edge along bumper and around corner to the 70 mm point (Figure 1).
  - Do not measure from visible bumper front of corner, upwards (Figure 2).

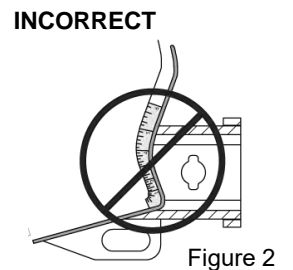
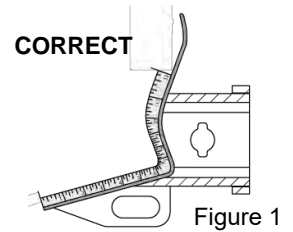

#### Drilling

- For any required drilling during installation, ensure that the area is clear of fuel, electrical & other components that may be damaged.
- All holes drilled into metal body panels shall have all burrs & swarf removed then coated with a suitable rust preventative paint.

#### Bolts/Fasteners

- Ensure that all hardware is fastened to correct torque as specified in this fitting instruction.
- All fasteners supplied with this product are used to achieve a specified clamp loading. If replacement is required ensure that fasteners of the same grade and class are used.

**NOTE: Achieving correct torque is critical to proper installation and responsibility of the installer. Towbar failures attributed to tension issues from over tightening or under tightening are not covered by Trailboss warranty.**

#### Product Labels

- a. Towbar load rating sticker provided with this product shall be conspicuously located on inside rear end of the driver's door.

#### WARNING:

**Do not, drill, cut, weld or otherwise modify the towbar.**

**FOR TOWING PURPOSES ONLY - This towbar is designed and tested by Trailboss to adhere to ADR 62/02 which provides only for the expected load demands of towing.**

### **i** TOWBAR ASSEMBLY DIAGRAM

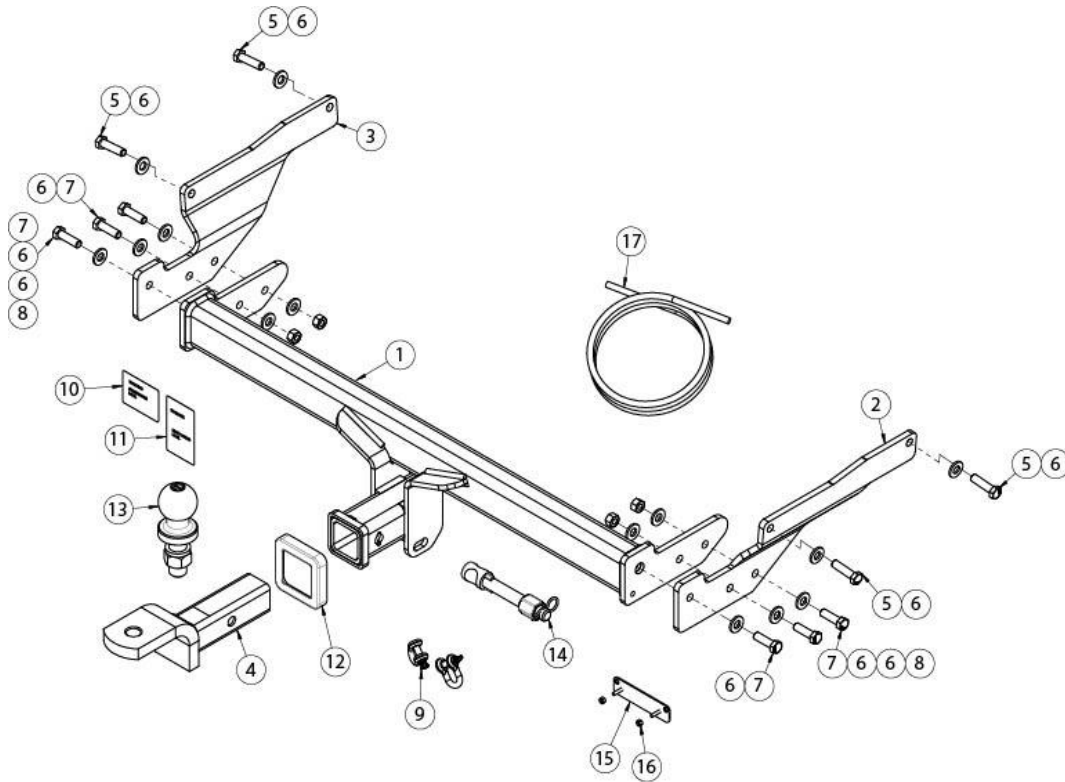

ITEM	DESCRIPTION	QTY
1	MAZDA CX-5 WELDED ASSEMBLY	1
2	SIDE ARM LHS	1
3	SIDE ARM RHS	1
4	TRAILER BALL MOUNT	1
5	SET SCREW HEX HD M12x45x1.25P	4
6	WASHER PLAIN 1/2"	14
7	SET SCREW HEX HD M12x40x1.75P	6
8	NUT HEX HD M12x1.75P	4
9	"D" SHACKLE 10mm	2

ITEM	DESCRIPTION	QTY
10	COMPLIANCE LABEL	1
11	LOAD RATING LABEL	1
12	HITCH BOX COLLAR COVER	1
13	TOWBALL 50mm	1
14	SMART PIN SILVER	1
15	PLUG BRACKET	1
16	NUT NYLOC HEX HD M4x0.7P	2
17	WIRING LOOM	1

1. Remove 2x plastic caps from bumper (both sides).

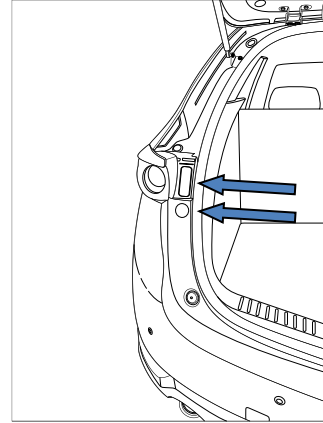

2. Remove 3 x screws located behind bumper caps.

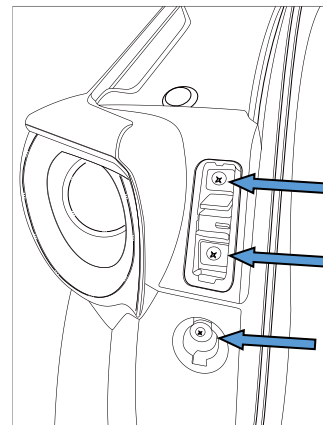

3. Carefully remove taillight by pushing it rearward of vehicle. Some force may be required.

Unplug taillights in 2 places.

Repeat both sides.

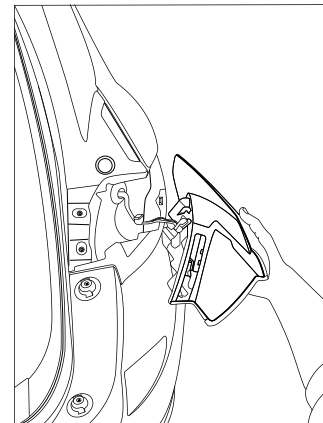

- 
4. Remove 1 x torx head screw along top of bumper.

Repeat for other side of vehicle.

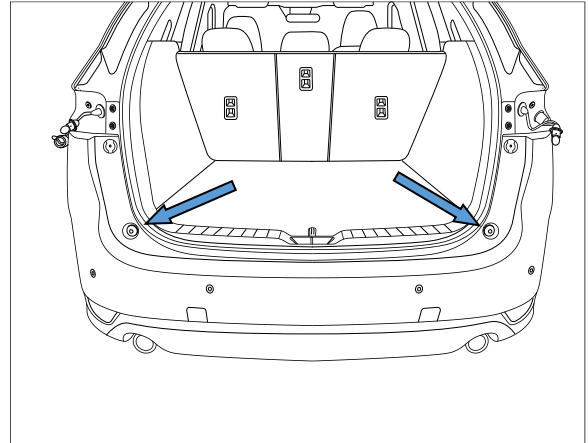

- 
5. Remove 1 x scrivets at base of wheel arch.

Repeat for other side of vehicle.

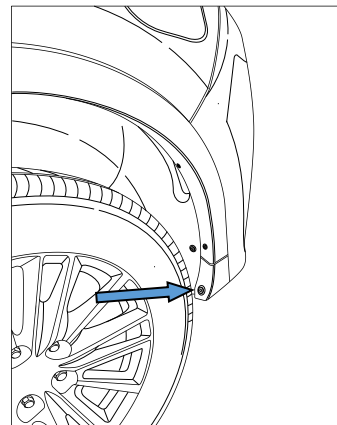

- 
6. Carefully peel wheel arch trim away from vehicle. Some force may be required.

Repeat for other side of vehicle.

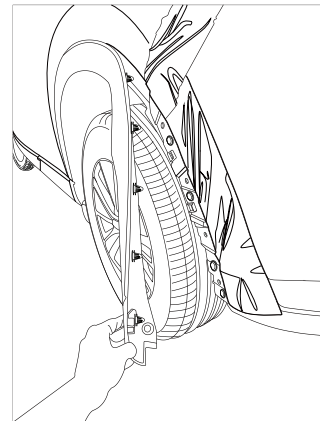

- 
7. Remove 4 x scrivenets and 1 x hex head screw behind wheel arch trim.

Repeat for other side of vehicle.

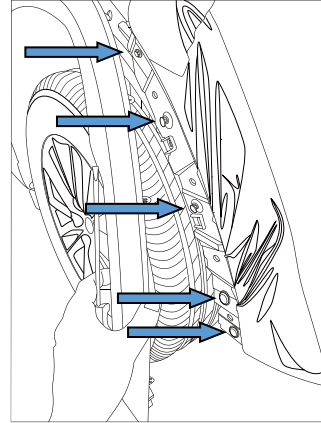

- 
8. Remove 2 x screw and 1 x scrivenets from underneath bumper.
- Repeat for other side of vehicle.

9. Flex bumper out at the sides then pull rearward to remove, some force may be required. Store the bumper in a safe location

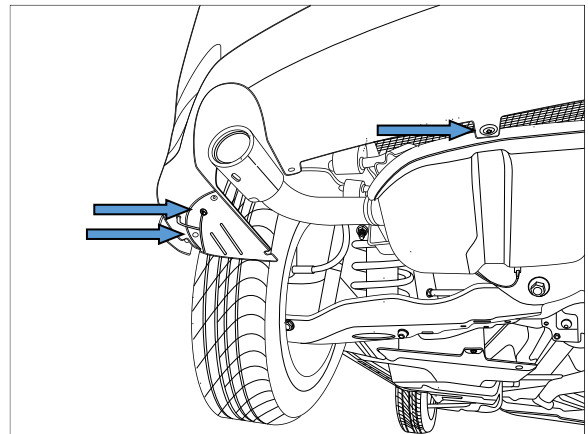

- 
10. Remove the tape on the chassis rail to expose the M12 captive nuts.

11. Remove the seam seal wherever needed to ensure a flat seating for the side arm on the chassis rail.

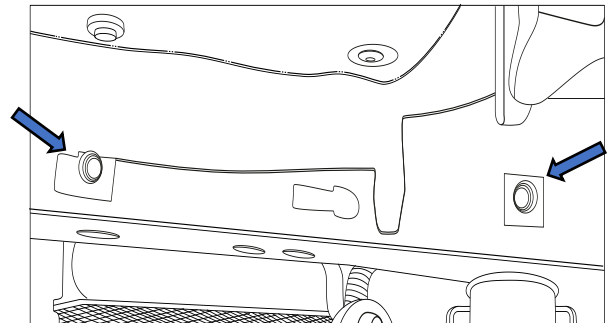

12. Lower rear muffler via 4x rubber hanger (2x per side) to gain better access.

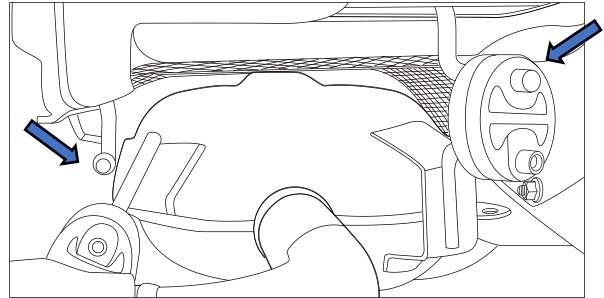

13. Place the side arm to the chassis frame and loosely secure with 2x M12 bolts complete with 1x washer per bolt.

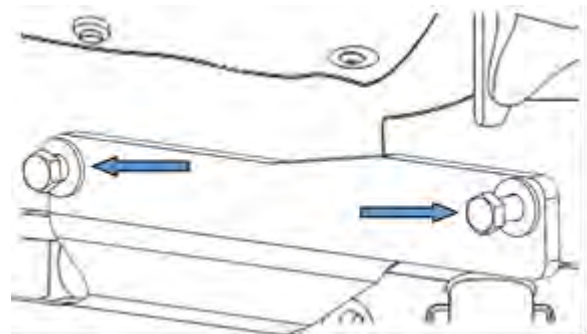

14. Position the cross tube between the side arms and loosely secure with each side with 3x M12 bolts, 5x washers and 2x nuts.

**Tighten all fasteners to the following torque:**

**M12x1.25 = 125 Nm.**

**M12x1.75 = 109 Nm**

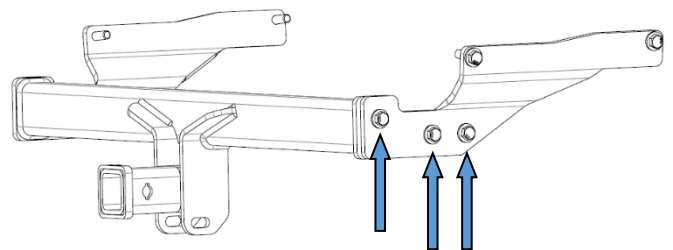

### 15. For Bumper cut.

#### For Pre Oct 2021 Bumper Cut

Find the centre of bumper, measure, mark out 120mm wide by 55mm long and cut bumper as shown ensuring there are no loose wires close to cut out.

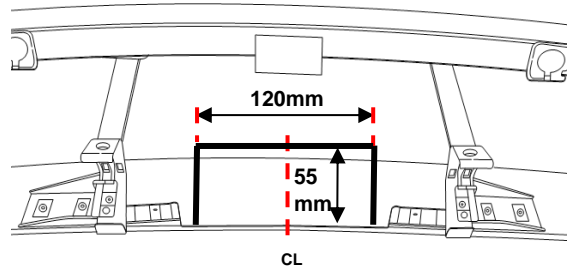

#### For Post Oct 2021 Bumper Cut

Find the centre of bumper, measure, mark out 120mm wide by 20mm long and cut bumper as shown ensuring there are no loose wires close to cut out.

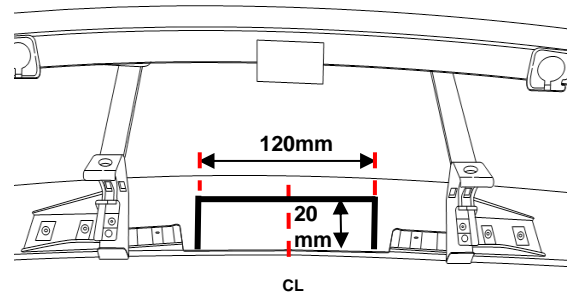

### 16. For plug bracket.

At an appropriate position on the bumper, mark out and drill 2x ø5mm holes 69mm apart on bumper skin to support plug bracket.

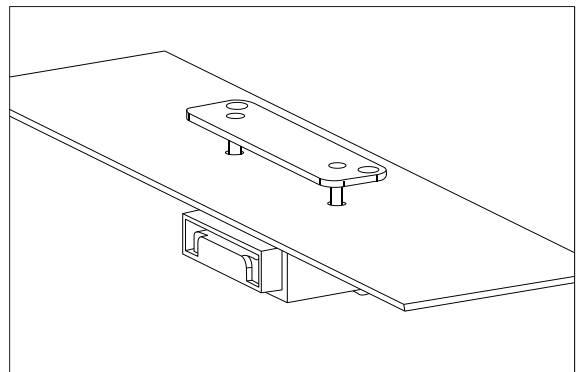



### IMPORTANT

Due to possible vehicle variations, always confirm any noted vehicle colour wires with a multi-meter to ensure the correct function is identified before soldering or scotch locking. For vehicle wires denoted with two colours (example; RED/GREEN) the first colour will always be the main wire colour while the second colour is the thinner trace colour on the wire.

17. Remove the floor cover carpets (1).

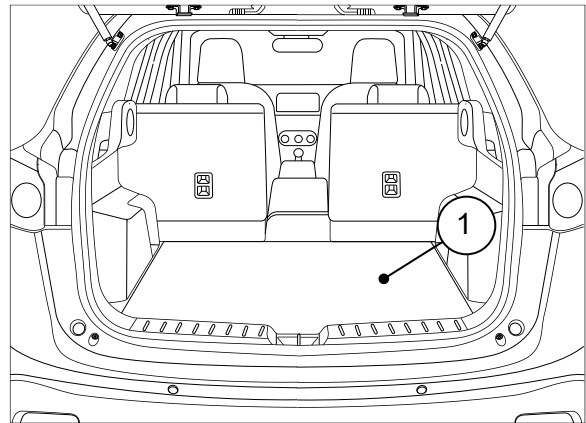

18. Remove bolt (1) in centre of spare tire.

19. Disconnect connector (3) located outside of spare tire.

20. Remove subwoofer (2).

21. Remove spare tire (4).

22. Remove the plastic trays (5).

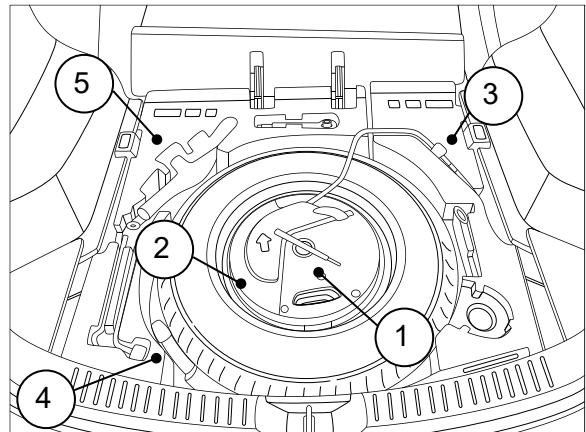

23. Remove the two clips (1), remove the rear luggage compartment trim by pulling in an upwards direction.

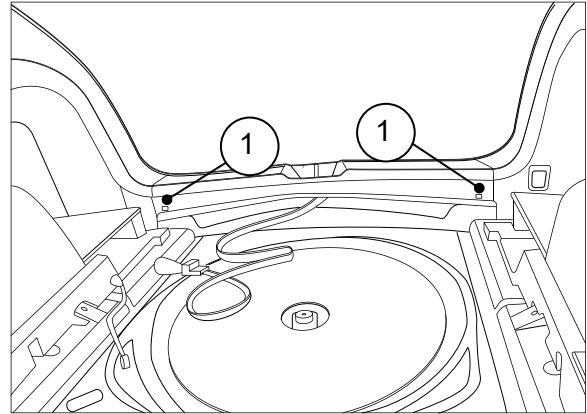

24. Remove the plastic screw cover and the two Phillips head screws (1).  
25. Remove the clip (2).  
26. Remove the two 10mm bolts (3) and remove the two tie downs.  
27. Dislodge the LHS luggage compartment trim (4).  
28. Repeat for RHS.

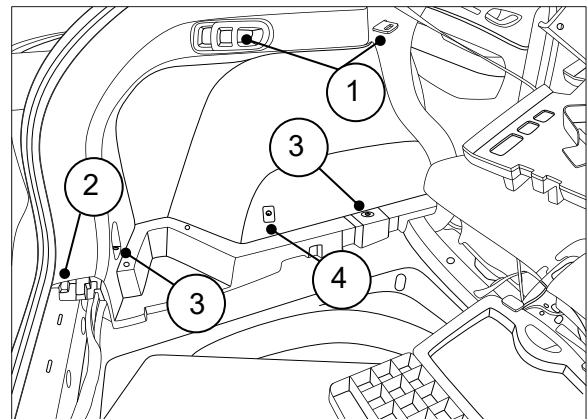

29. Remove the LHS front door sill trim (1).  
30. Dislodge the bottom of the rear LHS weather seal (4).  
31. Undo plastic nut (3) and remove the LHS kick panel trim (2).

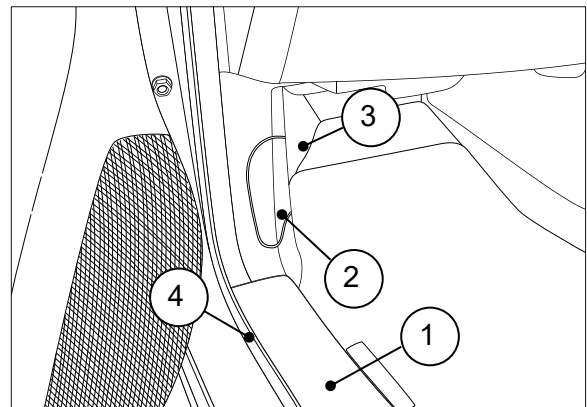

- 
32. Remove the LHS rear door sill trim (1).
  33. Dislodge the bottom of the rear LHS weather seal (2).
  34. Dislodge the base of the LHS 'B' pillar trim (3).

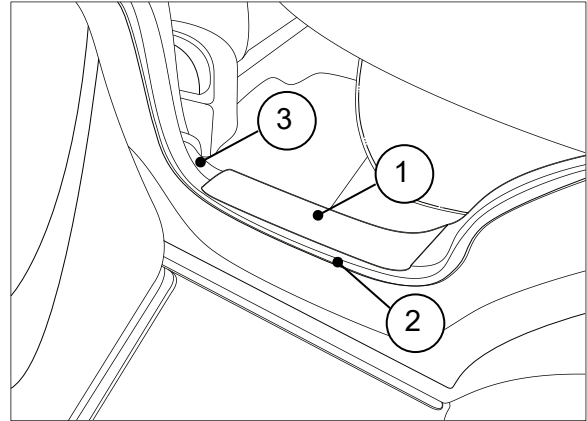

- 
35. Open the glove box compartment (1).
  36. Disconnect the damper (2).
  37. Squeeze both sides of the glove box compartment (1) and swing the drawer downwards towards the footwell.
  38. On each corner of the glove box compartment (1), pull the drawer towards the seat and remove from hinges.

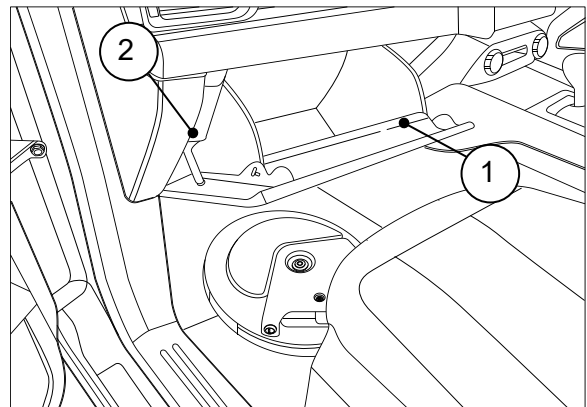

- 
39. Remove the under dash trim (1).

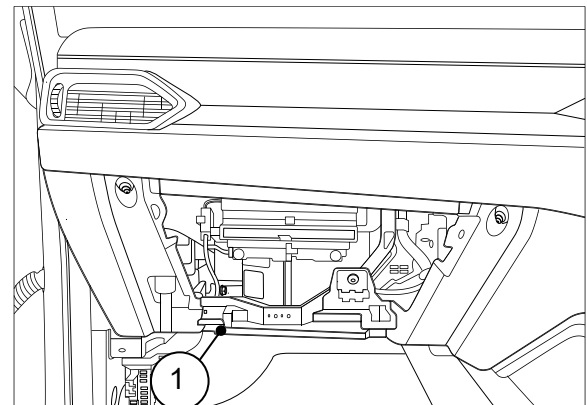

- 
40. At the rear of vehicle using an alcohol wipe (not supplied), clean the sheet metal inner skin exterior side (1) located behind the break out connector and grounding point area. This is where the ECU (P/No: 04836) will be mounted.
  41. Connect the trailer patch connector (2) to the ECU (3).
  42. Remove the backing from the back of the ECU and mount the ECU (3) onto the sheet metal area (1). Ensure ECU is mounted with the connector pointing downwards.
  43. Run the Trailer Wiring Harness (4) towards the LHS tail light connectors, following the existing vehicle harness.

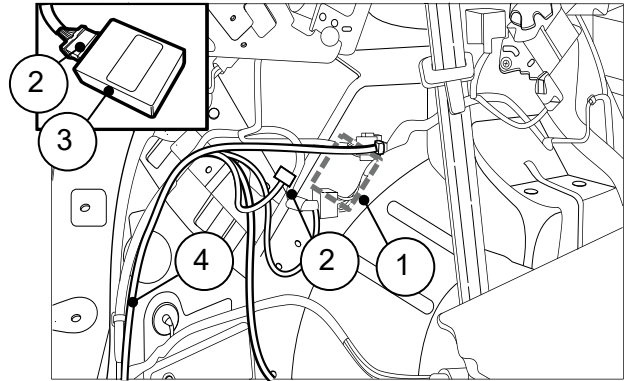

- 
44. Locate the ground point on the LHS wheel arch area. Secure the trailer patch ground ring terminal (1) to the vehicle grounding point (2) using the existing vehicle fastener.

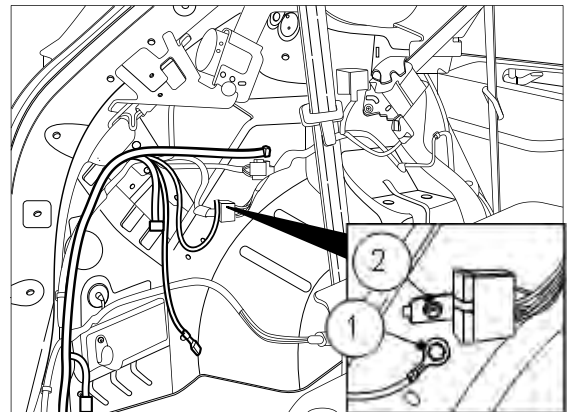

- 
45. Patch in the Trailer Wiring Harness 6-way connectors (1) into the LHS tail light connectors (2).

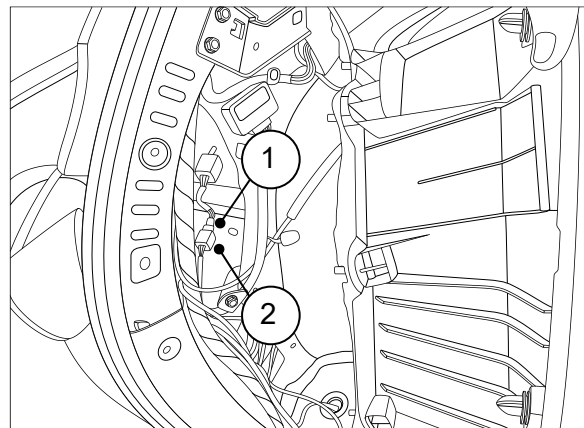

46. Following the existing vehicle harness (1), route the Trailer Wiring Harness (2) along the rear and towards the RHS of the vehicle.
47. Run the Trailer Wiring Harness (2) towards the RHS tail light connectors (3).

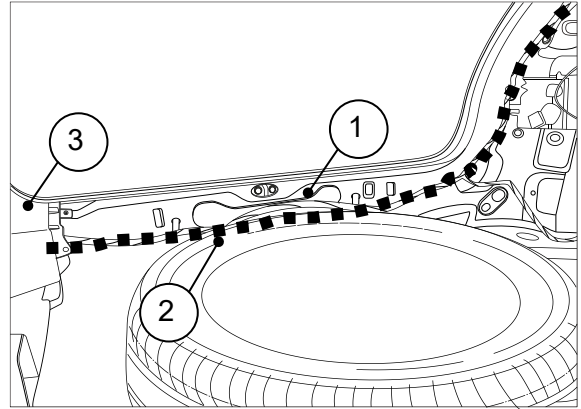

48. Patch in the Trailer Wiring Harness 6-way connectors (1) into the RHS tail light connectors (2).

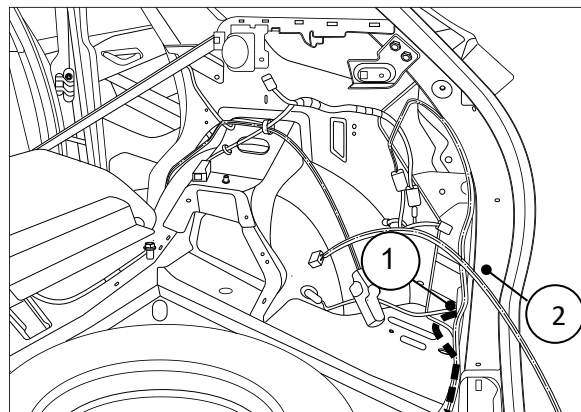

49. When reverse lights required, appropriately route the reverse patch terminal branch (1) up along the 'D' pillar and into the head lining.
50. Locate the vehicle harness connectors in the roof lining (not shown).
51. Using a multi-meter, locate the reverse wire signal (2) from the vehicle harness.
52. Connect the ezy-tap (3) to the located vehicle wire signal (2), then connect the trailer patch terminal (4) to the ezy-tap (3).

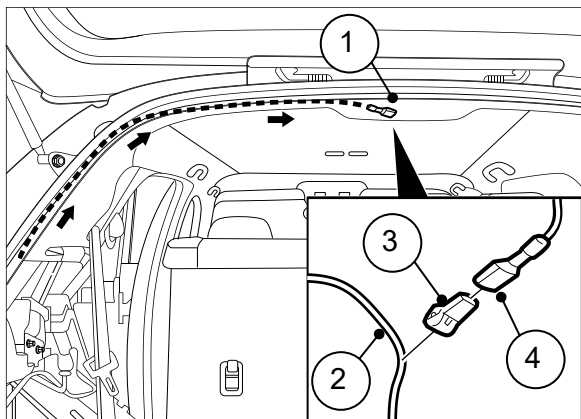

53. From the luggage compartment area (1), route the Power Line along the vehicle harness where possible, to the fuse panel located in the front passenger side foot well.

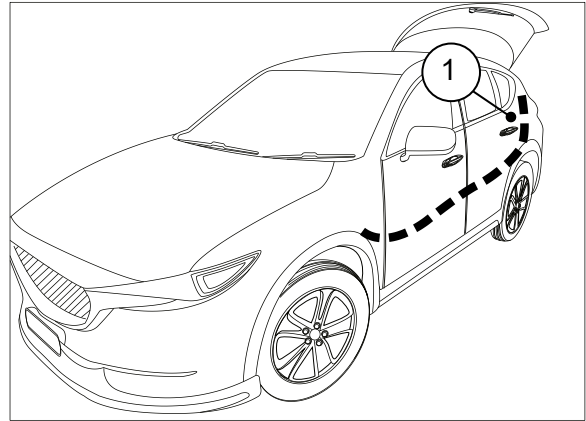

54. Locate the position where add-a-fuse will be placed (1) as shown.

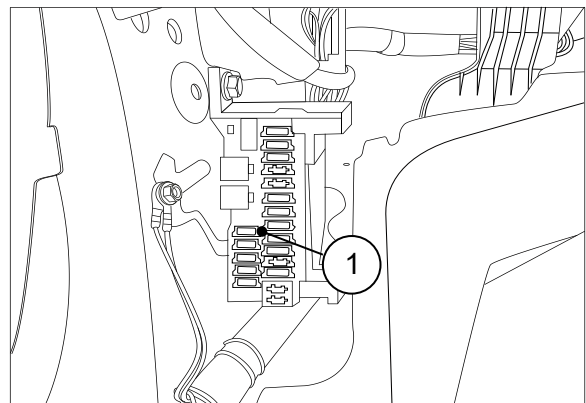

55. Make sure fuse orientation is applied as shown.

56. At the front passenger fuse panel area, insert the supplied fuse (20A) (1) into the add-a-fuse harness (2) upper slot.

57. Connect the add-a-fuse harness (2) 1-way connector to the trailer patch 1-way connector (3). Insert the add-a-fuse (2) into the empty fuse location (4). Ensure the add-a-fuse is mounted in the orientation as shown.

58. Connect add-a-fuse to power connector, then route power connector towards rear of vehicle, following existing harness where possible.

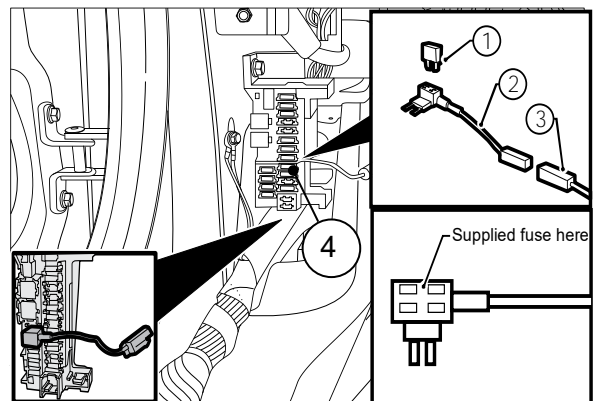

59. In the glovebox cavity, unplug the vehicle's reverse park assist module (1).

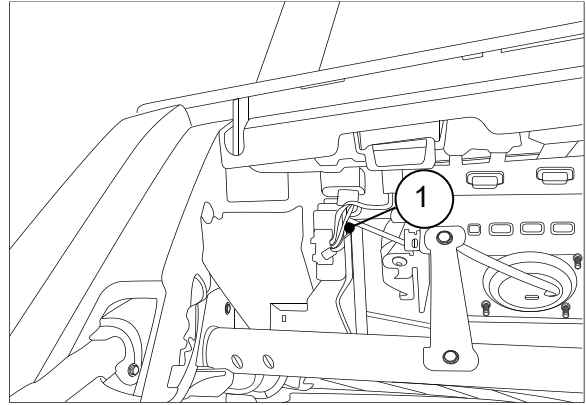

60. Plug in the RPA Disable Patch Harness (2) into RPA module (1).  
61. Connect vehicle harness (3) into the RPA disable.

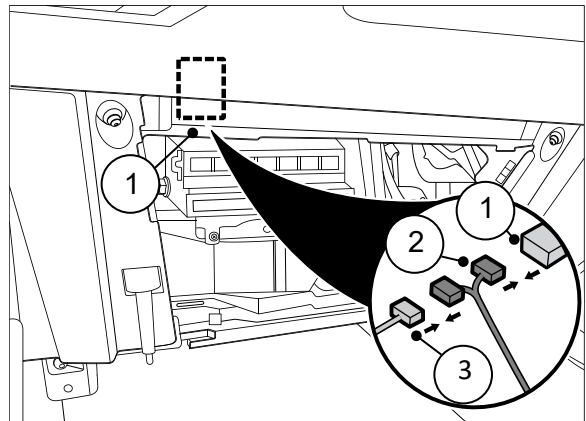

62. Route the RPA Disable patch (1) towards the LHS rear of the vehicle, following existing vehicles harness where possible.

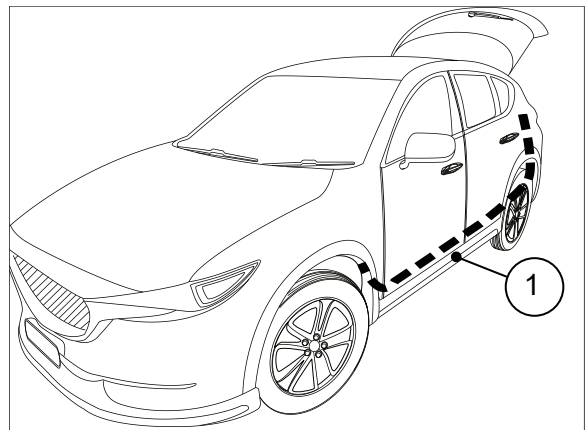



63. Connect the trailer wiring harness 1-way connector (1) to the RPA disable mating 1-way connector (2).

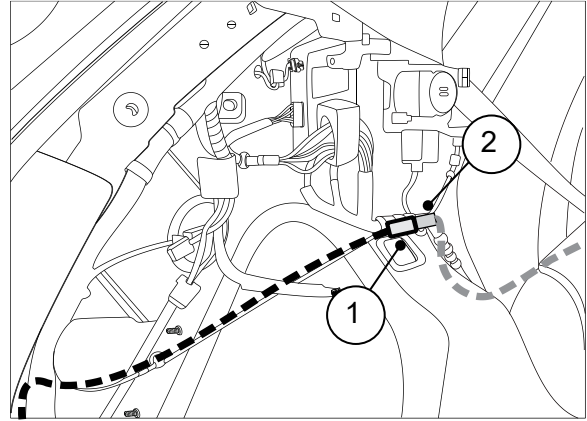

64. Feed blue connector of tail (P/No: 04944) through the grommet hole (1).

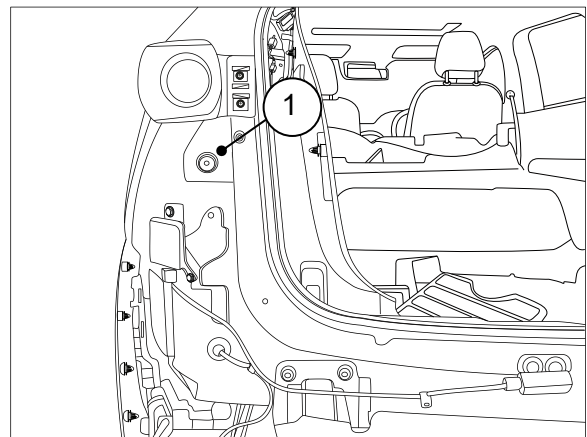

65. At the rear exterior of the vehicle, mount the tail harness socket (1) to the towbar mounting bracket using M4 fasteners (not supplied).
66. Route the tail harness (tail length: 1800mm) (2) across the LHS and up into the exposed grommet hole (3).
67. Adjust the trailer patch harness grommet so that it is seated correctly and cable tie (not supplied) in place.

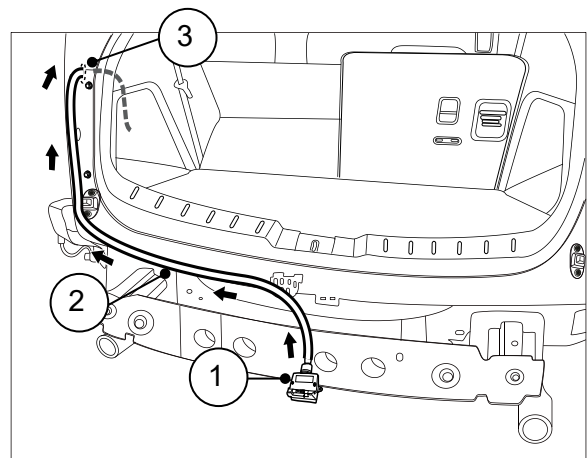



- 
68. Connect the tail harness 8-way connector (1) to the trailer patch 8-way mating connector (2).
  69. Connect wires with crimp and insulate connections.

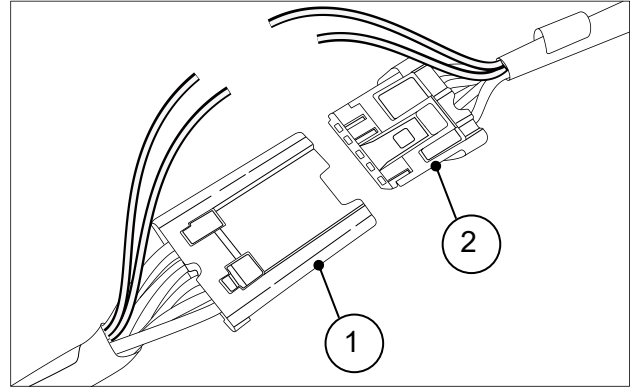

- 
70. Test the trailer wiring harness function using a light board or multi-meter.
  71. Secure all harnesses using cable ties (not supplied).
  72. Re-fit all removed parts and secure all fasteners, ensuring there are no squeaks or rattles.
  73. Place the fitting instructions in the glove box after fitment.
-



## CUSTOMER INFORMATION

PLACE THESE INSTRUCTIONS IN THE  
VEHICLE'S GLOVEBOX AFTER INSTALLATION

**THANK YOU FOR PURCHASING TRAILBOSS. WITH CORRECT MAINTENANCE AND CARE  
THIS PRODUCT WILL PROVIDE A LIFETIME OF TROUBLE-FREE OPERATION.**

### **TOWBAR MAINTENANCE AND CARE:**

1. Trailboss recommend that the towbar LUG or TBM (Trailer Ball Mount) Pull Pin and R-clip are removed and stored when not in use. Removal of LUG or TBM (Trailer Ball Mount) is advisable when not in use to assist with any of the following.
  - Ensure rear number plate is not obscured.
  - Allow maximum available departure angle and prevent any potential interference.
  - Prevent possible interference with vehicles reverse sensors or camera detecting a tow ball mount as an obstruction during reversing.
  - Removes towball mount as an obstruction for when moving around the rear of the vehicle.
2. Trailboss recommends routine inspection of your towbar to ensure trouble free towing.
  - Bolt security and tension should be regularly inspected and checked for correct tension. Replace any worn or defective parts with suitable grade & class fasteners. Inspection should be requested to coincide with vehicle major services.
3. It is the owner's responsibility to ensure towing and down ball weight capacities of the towing vehicle are not exceeded.
  - Towing and down ball weights allowable may differ according to model variations. Please refer to owner's manual or vehicle dealer to confirm exact rating for your vehicle model variant.
  - It is not uncommon for the vehicle tow rating to differ from the towbar rating. When this occurs, the lesser rating must be adhered to.
  - For vehicles fitted with enhanced vehicle functions that may be altered/changed when towing i.e Trailer sway mitigation, blind spot detection, adaptive cruise control etc. Please consult owner's manual to understand changes enabled when towing and after towing.

### **WARRANTY INFORMATION:**

Trailboss Towbars are covered by a Lifetime Warranty.

Our goods come with guarantees that cannot be excluded under the Australian Consumer Law. You are entitled to a replacement or refund for a major failure and for compensation for any other reasonably foreseeable loss or damage. You are also entitled to have the goods repaired or replaced if the goods fail to be of acceptable quality and the failure does not amount to a major failure.

For further details please contact customer service on 1800 812 017.

## PRO SERIES SILENT ANTI-RATTLE HITCH PIN

Your Trailboss towbar is equipped with a Pro Series Silent Anti-Rattle Hitch Pin technology to help reduce towbar tongue rattle in most driving conditions. Please ensure below instructions are understood and routine maintenance is carried out to ensure best towing experience.

Regularly inspect for wear and check the tightness of the Silent Anti-Rattle Hitch Pin. Follow instructions below to re-tighten the nut as necessary when movement and noise in the tow ball mount is noted.

- Before towing, ensure R-Clip is properly installed and hitch pin nut is installed and tensioned. Replacement parts are available from your Pro Series Distributor.

## TOWBALL MOUNT REMOVAL/INSTALLATION

### STEP 1

Insert Trailer Ball Mount (TBM) (a) into towbar hitchbox (b), aligning hole in TBM shank (c) with hole in hitchbox (d) (Fig. 1)

### STEP 2

Insert Silent Anti-Rattle Hitch Pin (e) through hole in hitchbox and hole in TBM shank (g); ensure the locators are inserted into the notches in the hitchbox (Fig. 2)

### STEP 3

Screw Silent Anti-Rattle Hitch Pin Nut (f) onto Smart Pin (g); tighten Smart Pin Nut until finger tight, ensuring TBM is restrained from up and down movement.

### STEP 4

Tighten Silent Anti-Rattle Hitch Pin Nut by turning nut a further 1/8th of a turn in the clockwise direction using a 24mm spanner (Fig. 4).

### STEP 5

Install Silent Anti-Rattle Hitch Pin R-Clip through the hole that provides best clearance or easiest access. (Fig. 5)

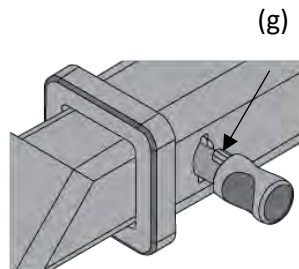
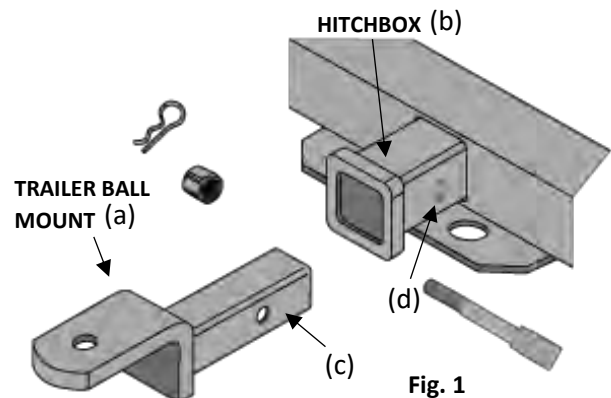

Fig. 2

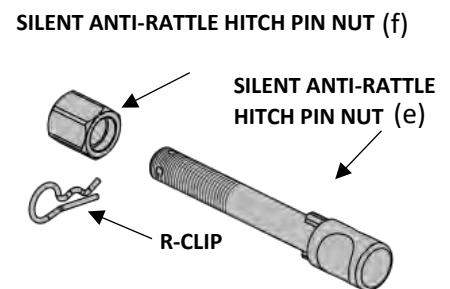

Fig. 3

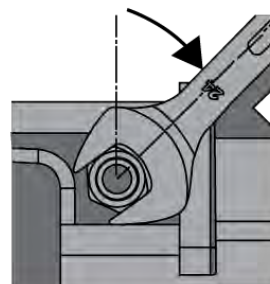

Fig. 4

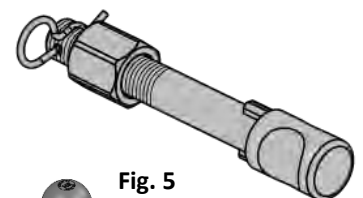

Fig. 5

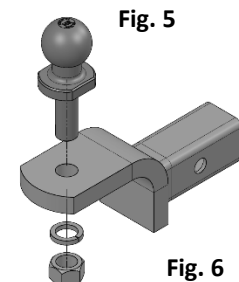

Fig. 6