



**Towbar Fitting Instructions**  
 To Suit **Mercedes Benz M & ML including AMG** 10/07 on  
 Part Number **QTMB270L**  
 Rating **3500** kg max, refer owner manual for ball weight

**WARNING:**

1. Do not, drill, cut, weld or otherwise modify the tow bar.
2. If you are using electric welding on a motor vehicle, **always** check that the vehicle is not equipped with electronic engine or instrument management equipment. Failure to do so could **destroy** any onboard computers. If in doubt, check with the vehicle's manufacturer.

**General:**

1. Ensure all hardware items have been included refer to assembly diagram.
2. It is recommended that the instructions are read through and completely understood before making any attempt to fit this product.
3. Be wary of any changes to vehicle designs or other accessories that may conflict with the installation of this product.
4. Before drilling ensure that the area is clear of fuel, electrical & other components.
5. All holes drilled into the body panels shall have all burrs & swarf removed then coated with a suitable rust preventative paint.
6. For vehicles that require the bumper to be cut. Ensure cut out area is in correct position on the vehicle prior to cutting the bumper.
7. The high tensile fasteners supplied with this product were used to achieve the specified rating. If replacement is required ensure that fasteners of the same rating & quality are used. Contact an authorized **Trailboss** dealer if further information is required.
8. Ensure that all hardware is fastened to torque list below check fasteners on regular basis.
9. Tow bar load rating sticker provided with this product shall be conspicuously located on inside rear end of the driver's door. **(See diagram below).**
10. Trailboss recommends that you check your tow ball to ensure that it complies with the Australian standards **AS 4177.2.**
11. **PLEASE NOTE:** It is advised to remove your lug or tbn when not actually towing so as to produce a clear view of the vehicles registration plate if obscured, and to also provide maximum available departure angle

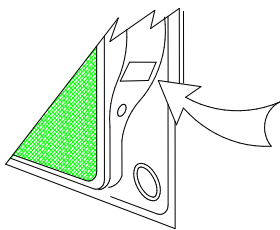

Place load rating sticker inside driver's door here

**FOR TOWING PURPOSES ONLY**  
 For towing capacity details please refer to vehicle owner's manual or to the manufacturer. Overloading can void your warranties.

**RECOMMENDED ASSEMBLY TORQUE LISTING**

Diameter	Grade 8.8 Bolt
M6	9.5 Nm
M8	21.7 Nm
M10	43.4 Nm
M12	77.3Nm
M14	146 Nm
M16	189.8 Nm

**Tow bar Maintenance and Care.**

Trailboss recommends that bolt torque's, as listed below, are routinely and regularly inspected and checked for correct tension. Replace any worn or defective parts.  
 We recommended to remove Tow Ball Mounts (TBM's, tongues or lugs) when not being used for any considerable length of time.  
 So as to avoid injury, when not towing it is suggested that the tongue, Pull Pin and R-clip are removed then stored in a safe, clean and dry place, away from excessive moisture.  
 Hitch Pull Pins and spring "R" clips are regularly checked for proper installation. Replace any worn or defective parts.



Towbar Fitting Instructions  
To Suit Mercedes Benz M & ML including AMG 10/07 on  
Part Number QTMB270L  
Rating 3500 kg max, refer owner manual for ball weight

1. Ensure all hardware items have been included
2. Remove rear bumper bar.
  - a. Remove rear mud flaps, 3 torque screws and 2 x M5 bolts.
  - b. Remove 1 x M5 bolt from wheel arch of rear quarter as shown in fig1.
  - c. Remove 6 x M5 bolts from the lower lip of the bumper bar and mounting brackets.
  - d. Remove rear quarter panel doors on the driver as well as passenger side as shown in figure 2. Also remove all the other bolts as shown in figure 3 in order to remove the panel at the bottom of rear luggage area.
  - e. Remove medical panel from the passenger side of car, when the rear quarter access door is opened.
  - f. Remove 4 bolts from the opened panels, 2 bolts each from the Driver's as well as the passenger sides (One bolt towards the rear panel and one from rear quarter).
  - g. Disconnect reversing sensors from the passenger side of rear quarter open panel.
  - h. Remove bumper bar.
3. Remove and discard impact beam.
  - a. Remove mufflers from the 4 rear most hangers.
  - b. Remove muffler heat shields on both Driver and passenger sides.
  - c. Remove plastic trim as shown in figure 4 by removing two bolts on driver's side.
  - d. Remove spare wheel cover lid as shown in Fig 5 and the spare wheel.
  - e. Remove the black panels on both sides on the rear quarter of the car.
  - f. Remove 8 nuts holding the impact beam (4 from underneath the car and 4 from inside the luggage area).
4. Remove and discard centre bumper mounting bracket.
5. Insert passenger and driver side arms into the chassis rails. Figure 6 & 7 shows the bolt holes to be used to fit the side arms to the chassis.
6. Fit bolts, nuts, loose plates and washers loosely as per drawing.
7. Fit the centre section of the towbar; fit all bolts supplied as per drawing.
8. Tighten all bolts to torque listing.
9. Cut bumper bar as shown in Figure 8 and trim & fit Pinch weld supplied.
10. Refit all the panels and hardware in reverse of removal.
11. Using suitable lubricant to manoeuvre rear most exhaust rubber back onto hanger.
12. Towbar rating sticker to be conspicuously located on inside rear end of the driver's door.  
**(see diagram below)**

# TRAILBOSS

Towbar Fitting Instructions  
To Suit Mercedes Benz M & ML including AMG 10/07 on  
Part Number QTMB270L  
Rating 3500 kg max, refer owner manual for ball weight

Fig 1

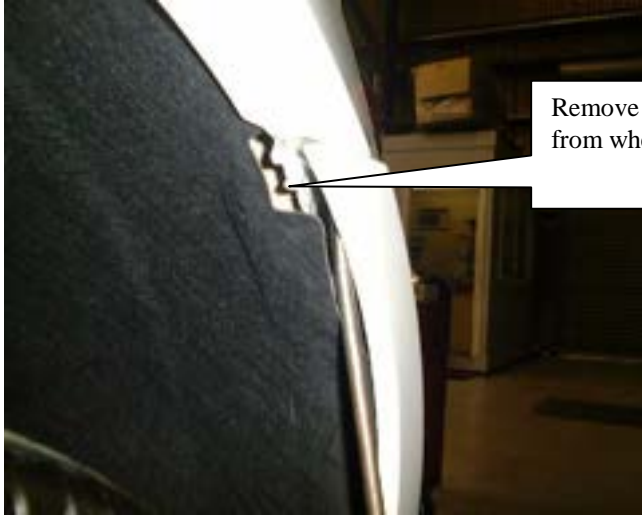

Remove 1 M5 bolt  
from wheel Arch.

Fig 2



Fig 4

Remove the rear quarter panel doors as shown, on both driver and passenger sides. Medical panel to be removed and reversing sensors disconnected from passenger side.

Fig 3

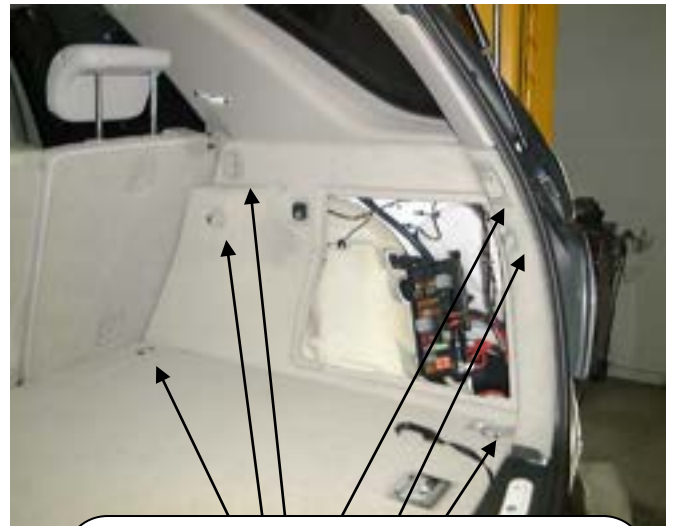

Remove all the bolts as pointed with the arrows on both the passenger as well as the driver sides in order to remove the panel at the bottom.

# TRAILBOSS

Towbar Fitting Instructions  
To Suit Mercedes Benz M & ML including AMG 10/07 on  
Part Number QTMB270L  
Rating 3500 kg max, refer owner manual for ball weight

Fig 4



Remove plastic trims by removing 2 bolts on drivers side (Bolts are on the inside, cannot be seen on figure). Also remove spare wheel cover lid, spare wheel and black panels on both sides in order to get to the bolts of the impact beam.

Fig 5



Spare wheel lid cover can be removed by removing the bolts just behind the rear seats on both the driver and passenger sides.

Fig 6

Fig 7

# TRAILBOSS

Towbar Fitting Instructions  
To Suit Mercedes Benz M & ML including AMG 10/07 on  
Part Number QTMB270L  
Rating 3500 kg max, refer owner manual for ball weight



All these Panels and hardware needed to be removed in order to access these bolt holes as pointed out by arrows, on both sides of the rear quarter of the car. These are the holes through which the side arms of the towbar should be bolted on to the chassis.

Fig 8: Bumper cut-out



# TRAILBOSS

## Towbar Fitting Instructions To Suit Mercedes Benz M & ML including AMG 10/07 on Part Number QTMB270L Rating 3500 kg max, refer owner manual for ball weight

**PLEASE NOTE:** You must remove the lug unless you are actually towing if it obscures your number plate. Failure to do so may result in a fine.

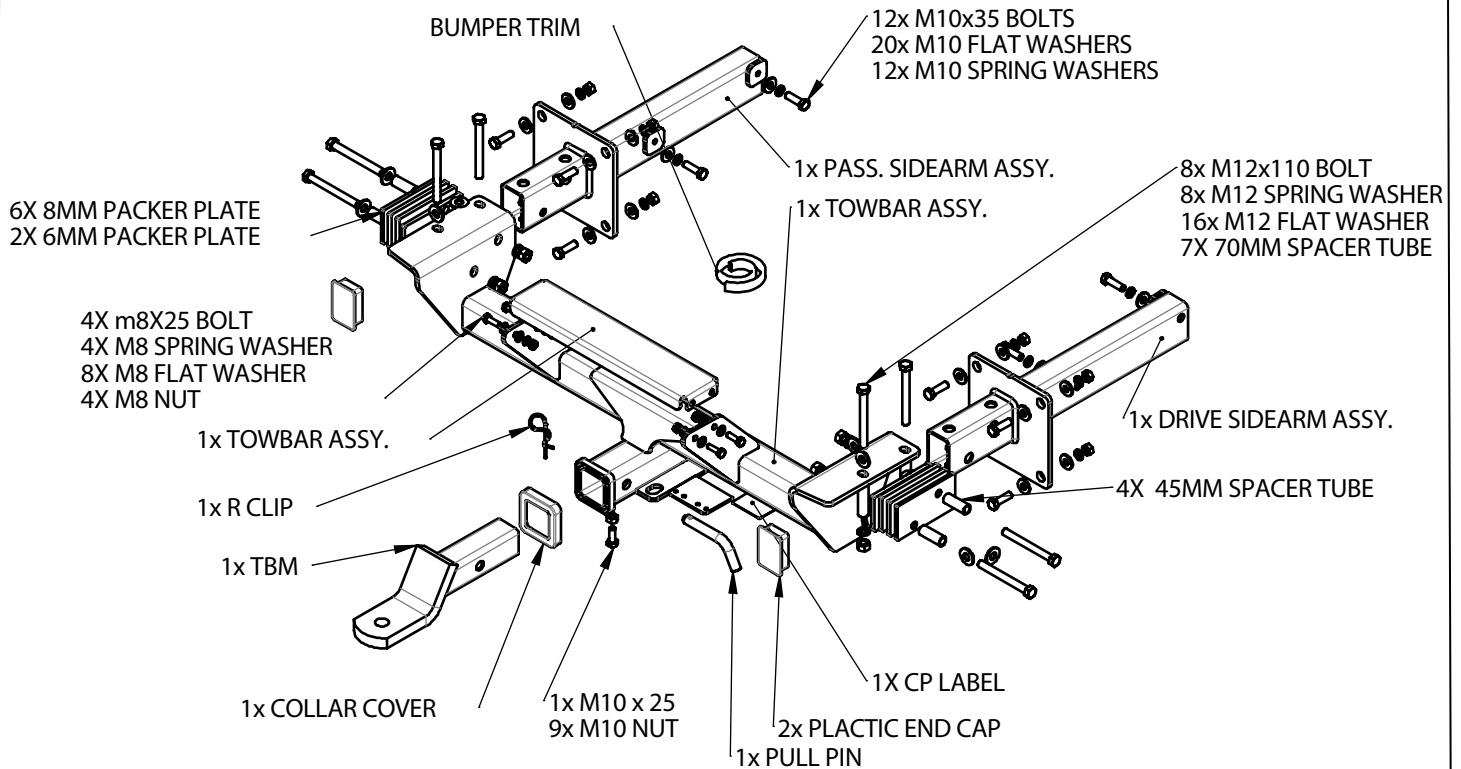



Towbar Fitting Instructions  
To Suit Mercedes Benz M & ML including AMG 10/07 on  
Part Number QTMB270L  
Rating 3500 kg max, refer owner manual for ball weight

## Wiring Loom Installation Instructions

**MERCEDES ML 320**  
**Part No: 100261-WL**

**ECU Required: 04833**  
**Tail Harness Length Required: 1200mm**  
**RPA Override Switch Part No: 04848 (If Fitted)**

**Wiring Loom Installation Time: Approx 30 Mins**

1. In the luggage compartment, remove the floor carpet cover (1).
2. Remove the LHS & RHS access panel covers (2).



# TRAILBOSS

## Towbar Fitting Instructions

To Suit Mercedes Benz M & ML including AMG 10/07 on  
Part Number QTMB270L

Rating 3500 kg max, refer owner manual for ball weight

3. Remove the rear trim (1) by first removing the two fasteners (2).



4. Locate the LHS tail light connector.  
5. Patch in the Trailer Harness (P/No: 100261-WL) mating connectors (1).  
6. Route the Trailer Harness (2) across the rear of the luggage compartment and towards the RHS tail light cavity.



7. Locate the RHS tail light connector (1).  
8. Patch in the Trailer Harness mating connectors (2).





Towbar Fitting Instructions  
To Suit Mercedes Benz M & ML including AMG 10/07 on  
Part Number QTMB270L  
Rating 3500 kg max, refer owner manual for ball weight

9. Drill a Ø31mm hole (1) in the vehicle sheet metal on the RHS of the luggage compartment.
10. File any rough or sharp edges and spray on rust inhibitor.



11. Secure the Trailer Harness power ring terminal (1) to the fuse panel power terminal (2).
12. Secure the Trailer Harness ground ring terminal (3) to the vehicle grounding point (4).



13. Connect the trailer patch harness 12-way connector (1) to the ECU (04833) (2).

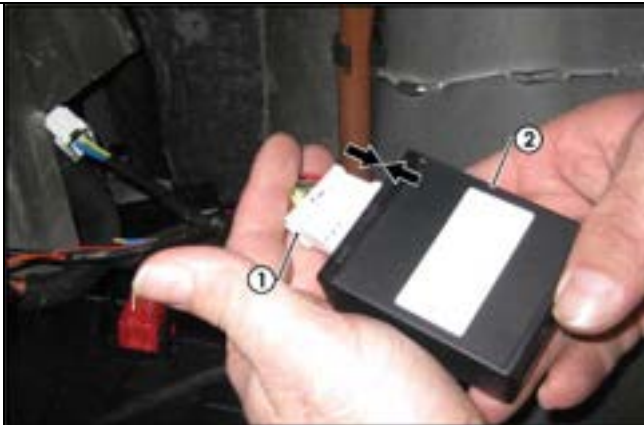

## Towbar Fitting Instructions

To Suit Mercedes Benz M & ML including AMG 10/07 on  
Part Number QTMB270L

Rating 3500 kg max, refer owner manual for ball weight

14. Apply double sided tape to the ECU (1) and adhere it to the vehicle sheet metal on the RHS of the luggage compartment.



15. Mount the Trailer Socket (1) to the towbar mounting bracket using M4 fasteners (not supplied).
16. Route the Tail Harness (tail length 1200mm) (2) across the towbar towards the RHS of the vehicle and up through the previously drilled out hole.
17. Ensure the Tail Harness grommet is seated correctly and secure in place using a cable tie (not supplied).



18. Connect the tail harness 8-way connector (1) to the trailer harness mating 8-way connector (2).





### Towbar Fitting Instructions

To Suit Mercedes Benz M & ML including AMG 10/07 on  
Part Number QTMB270L

Rating 3500 kg max, refer owner manual for ball weight

- |   |  |
|---|--|
| <ol style="list-style-type: none"><li>19. Test the Trailer Harness function using a Light Board or multimeter.</li><li>20. Secure all Harnesses using cables ties (not supplied).</li><li>21. Re-fit all removed parts and secure all fasteners, ensuring there are no squeaks or rattles.</li><li>22. Place the instructions in the glove box after fitment.</li></ol> |  |
|---|--|