

# TRAILBOSS

Towbar Fitting Instructions  
To Suit **MERCEDES BENZ V-CLASS, VITO & VALENTE 447 SERIES**  
Part Number **QTMB416L**  
Rating **2500/250 kg**

PLACE THESE INSTRUCTIONS IN THE VEHICLE'S GLOVEBOX AFTER INSTALLATION IS COMPLETED

## **WARNING:**

1. Do not, drill, cut, weld or otherwise modify the tow bar.
2. If you are using electric welding on a motor vehicle, **always** check that the vehicle is not equipped with electronic engine or instrument management equipment. Failure to do so could **destroy** any onboard computers. If in doubt, check with the vehicle's manufacturer.
3. The high tensile fasteners supplied with this product were used to achieve the specified rating. If replacement is required ensure that fasteners of the same rating & quality are used. Contact an authorised **Trailboss** dealer if further information is required.
4. If TBM is used in inverted position tow ball may make contact with rear tailgate when lowered, which could cause damage.

## **General:**

1. Ensure all hardware items have been included refer to assembly diagram.
2. It is recommended that the instructions are read through and completely understood before making any attempt to fit this product.
3. Be wary of any changes to vehicle designs or other accessories that may conflict with the installation of this product.
4. Before drilling ensure that the area is clear of fuel, electrical & other components.
5. All holes drilled into the body panels shall have all burrs & swarf removed then coated with a suitable rust preventative paint.
6. For vehicles that require the bumper to be cut. Ensure cut out area is in correct position on the vehicle prior to cutting the bumper.
7. The high tensile fasteners supplied with this product were used to achieve the specified rating. If replacement is required ensure that fasteners of the same rating & quality are used. Contact an authorized **Trailboss** dealer if further information is required.
8. Ensure that all hardware is fastened to torque list below check fasteners on regular basis.
9. Tow bar load rating sticker provided with this product shall be conspicuously located on inside rear end of the driver's door. **(See diagram below).**
10. Trailboss recommends that you check your tow ball to ensure that it complies with the Australian standards **AS 4177.2**.
11. **PLEASE NOTE:** It is advised to remove your lug or tbm when not actually towing so as to produce a clear view of the vehicles registration plate if obscured, and to also provide maximum available departure angle
12. Pull Pin must be fit in down position.

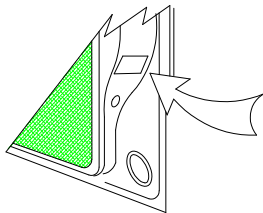

Place load rating sticker  
inside driver's door here

**FOR TRAILER TOWING PURPOSES ONLY**  
For towing capacity details please refer to vehicle owner's manual or to the manufacturer. Overloading can void your warranties.

### **RECOMMENDED ASSEMBLY TORQUE LISTING**

Diameter	Grade 8.8 Bolt
M6	9.5 Nm
M8	21.7 Nm
M10	43.4 Nm
M12	77.3Nm
M14	146 Nm
M16	189.8 Nm

## **Tow bar Maintenance and Care.**

Trailboss recommends that bolt torque's, as listed below, are routinely and regularly inspected and checked for correct tension. Replace any worn or defective parts.

We recommended to remove Tow Ball Mounts (TBM's, tongues or lugs) when not being used for any considerable length of time.

So as to avoid injury, when not towing it is suggested that the tongue, Pull Pin and R-clip are removed then stored in a safe, clean and dry place, away from excessive moisture.

Hitch Pull Pins and spring "R" clips are regularly checked for proper installation. Replace any worn or defective parts.

# TRAILBOSS

## Towbar Fitting Instructions

To Suit **MERCEDES BENZ V-CLASS, VITO & VALENTE 447 SERIES**

Part Number **QTMB416L**

Rating **2500/250 kg**

PLACE THESE INSTRUCTIONS IN THE VEHICLE'S GLOVEBOX AFTER INSTALLATION IS COMPLETED

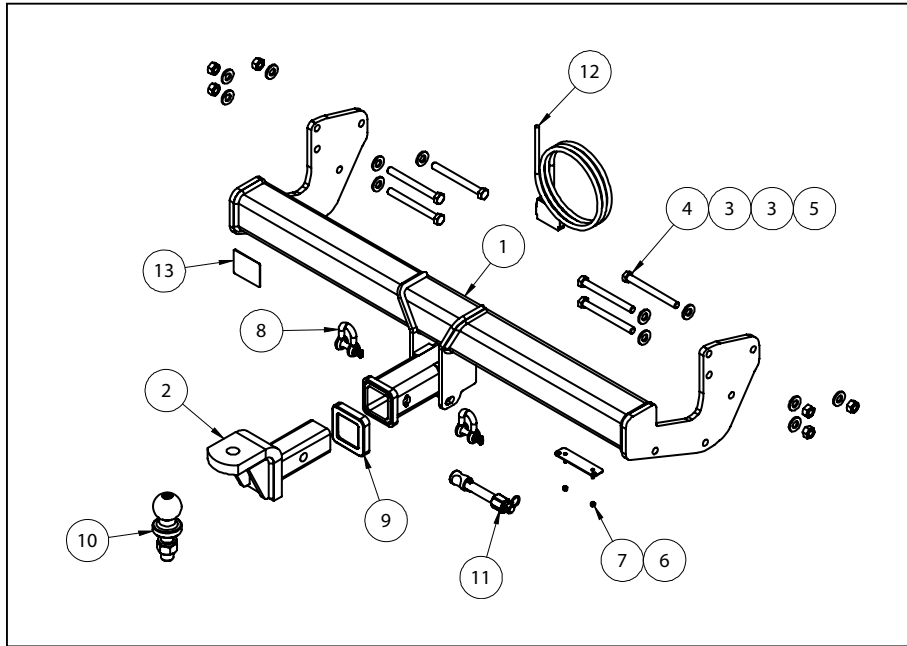

QTY.	DESCRIPTION	ITEM NO.
1	WELDED ASSEMBLY	1
1	TBM ASSY	2
12	WASHER FLAT 1/2"x1 1/8" x 1/8"	3
6	BOLT HEX HD M12x120x1.25P G10.9	4
6	HEX NUT M12x1.25 PC8	5
1	PLUT BRACKET	6
2	NUT NYLOC M4-0.7 Z/P	7
2	10mm "D" SHACKLE	8
1	HITCH BOX COLLAR COVER	9
1	50mm TOWBALL	10
1	SILENT HITCH PIN-SILVER	11
1	WIRING LOOM	12
1	ACRYLIC COMPLIANCE PLATE	13



Towbar Fitting Instructions  
To Suit **MERCEDES BENZ V-CLASS, VITO & VALENTE 447 SERIES**  
Part Number **QTMB416L**  
Rating **2500/250 kg**

PLACE THESE INSTRUCTIONS IN THE VEHICLE'S GLOVEBOX AFTER INSTALLATION IS COMPLETED

**INSTRUCTION:**

1. Release the tail gate to expose rear cabin of the vehicle.
2. Underneath the tail light, remove 2 x Torx Screws and 1 x Push Rivet. Repeat for opposite side.
3. Remove 4 x Torx Screws located on the top of the bumper.
4. On the inside of the guard liner, remove 1 x Push Rivet. Repeat for opposite side.
5. On the underside of the bumper near the wheel arch remove 1 x Push rivet. Repeat for opposite side.
6. Remove 2 x Push Rivets on the underside of the bumper.
7. Carefully remove bumper by peeling away at each edge. Store in a safe place for re-attachment.
8. Remove and discard factory shipping hook.
9. If fitted, detach plastic under tray by removing 2 x Plastic Nuts.
10. Offer Towbar to vehicle. Loosely secure it using 6 x M12 x 1.25P Set Screws with accompanying flat washers and nuts.
11. Torque all fasteners to the following specification: **M12 x 1.25P x G10.9 : 140Nm**
12. On the inside face of the bumper remove and discard internal reinforcement.
13. Locate the centre of the bumper and cut approximately 90mm up **ON THE SURFACE** of the bumper edge and 50mm wide on either side of the centre line.
14. If your vehicle is fitted with a plastic under tray. Cut a relief 160mm long and 40mm wide in line of the passenger side arm of the Towbar. Start from the rearward edge of the trim.
15. Mark out and drill 2x  $\varnothing$ 5mm holes 69mm apart on bumper skin to support plug bracket. Feed bracket threads through drilled holes prior to reinstalling bumper.
16. Re-attach bumper by following steps 1-9 in reverse.



Wiring Loom Fitting Instructions  
To Suit Mercedes Vito / Valente 447  
Part Number 101375-WL

### Wiring Loom Installation Instructions

Mercedes Vito / Valente 447

Part No: 101375-WL

ECU Required: 04828 (Incandescent Tail Lights)

ECU Required: 04827 (LED Tail Lights)

Tail Harness Length Required: 1800mm

Wiring Loom Installation Time:

Vito - Approx 30 Mins

Valente – Approx 45 Mins



Due to possible vehicle variations, always confirm any noted vehicle colour wires with a multi-meter to ensure the correct function is identified before soldering or scotch locking. For vehicle wires denoted with two colours (example; RED/GREEN) the first colour will always be the main wire colour while the second colour is the thinner trace colour on the wire.

# TRAILBOSS

## Wiring Loom Fitting Instructions To Suit Mercedes Vito / Valente 447 Part Number 101375-WL

**All Steps apply to all models unless otherwise specified.**

**The following Steps 1 to 3 for Mercedes Valente only. For Vito, start on Step 4:**

1. Gain access to the rear luggage compartment area and remove the RHS middle trim and dislodge the RHS lower trim by removing the required fasteners.
2. Dislodge enough of the LHS luggage compartment centre and lower trims by removing the required fasteners.
3. Dislodge the upper LHS and RHS trims and headlining to allow for harness routing later on.

**Steps 4 and 5 only for Vito models only:**

4. In the luggage compartment, remove the vehicle jack.
5. Remove the RHS panel by removing all the clips.

**The remaining Steps applicable to both Vito and Valente models with either incandescent or LED tail lights:**

6. Remove the LHS and RHS tail light assemblies by removing the two screws from each assembly.
7. Retrieve the LHS and RHS vehicle harness tail light connectors into the vehicle.
8. Drill out the existing RHS grommet hole (1) to Ø30mm (deburr and apply rust inhibitor after drilling).



## Wiring Loom Fitting Instructions To Suit Mercedes Vito / Valente 447 Part Number 101375-WL

**For models with LED tail lights, go to Step 10, otherwise, for models with incandescent tail lights, continue:**

- Following the table below, connect the trailer patch (P/No:101375-WL) ezy-taps (1) to the corresponding vehicle wires (2), then connect the trailer patch terminal (3) to the ezy-taps (1). **Scotch lock onto the vehicle harness location BEFORE the exterior harness grommet. Tape back the trailer patch BROWN / BLACK wire as it is not required.**

Function	Trailer Patch	Vehicle Connector
R.IND	GREEN / BLACK	BLACK / GREEN
BRAKES/TAILS	RED / BLACK	GREY / BLACK
REVERSE	BLACK / WHITE	WHITE / YELLOW

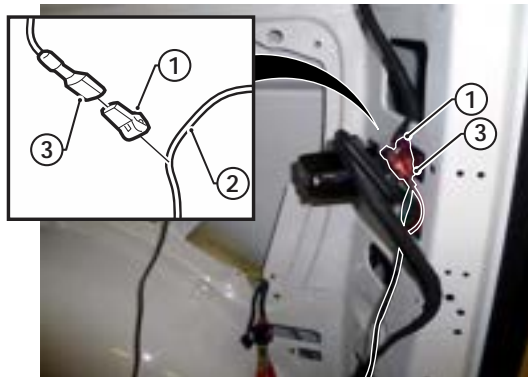

**This step only for models with LED tail lights:**

- Following the table below, connect the trailer patch (P/No:101375-WL) ezy-taps to the corresponding vehicle wires, then connect the trailer patch terminal to the ezy-taps. **Scotch lock onto the vehicle harness location BEFORE the exterior harness grommet.**

Function	Trailer Patch	Vehicle Connector
R.IND	GREEN / BLACK	BLACK / GREEN
BRAKES	RED / BLACK	GREY / BLACK
TAILS	BROWN / BLACK	BLACK / RED
REVERSE	BLACK / WHITE	WHITE / YELLOW

- For Vito models:** Route the trailer patch up the RHS cavity, across the cargo door and down the LHS cavity towards the tail light connector.
- For Valente models:** Route the trailer patch up the trim cavity and into the headlining. Continue to route the trailer patch across the roof and then down into the LHS tail light area.

## Wiring Loom Fitting Instructions To Suit Mercedes Vito / Valente 447 Part Number 101375-WL

13. In the upper LHS of the luggage compartment, locate the tail light wiring harness (2).
14. Following the table below, connect the ezy-taps (1) to the vehicle tail light wires (2) then connect the trailer harness wire terminal (3) to the ezy tap (1). **Scotch lock onto the vehicle harness location BEFORE the exterior grommet.**

Function	Trailer Patch	Vehicle Connector
L.IND	YELLOW/BLACK	BLACK / WHITE

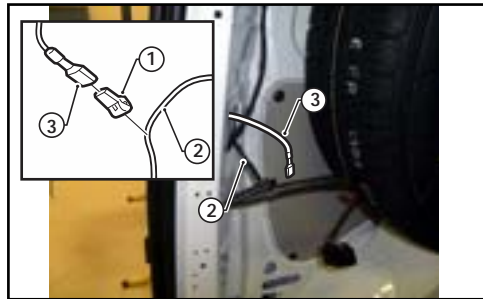

15. Secure the trailer patch ground ring terminal to the vehicle grounding point located on the area behind the RHS trim using the vehicle fastener.
16. Locate the RHS vehicle break out connector and strip back the RED/BROWN wire and solder the trailer patch ORANGE wire onto the RED/BROWN wire.  
**For vehicle models with LED tail lights, use ECU P/No: 04827.**  
**For vehicle models with incandescent tail lights, use ECU P/No: 04828**
17. Connect the trailer patch ECU connector to the ECU.
18. Clean the area on the sheet metal below the grounding point with an alcohol wipe (not supplied) and allow to dry. Peel off the backing from the ECU and mount the ECU into place.
19. Connect the tail harness 8-way connector to the Trailer Patch 8-way mating connector.
20. Refit the tail lights.
21. Test the Trailer Harness function using a light board or multi-meter.
22. Secure all harnesses using cable ties (not supplied).
23. Re-fit removed parts and secure all fasteners, ensuring there are no squeaks or rattles.
24. Place the instructions in the glove box after fitment.
25. RPA can be disabled via a switch on the dash panel.



# FITTING INSTRUCTIONS

## Silent Anti-Rattle Hitch Pin (PR0001)

• These fitting instructions are supplied to ensure understanding of how the HITCH PIN should be fitted and used correctly.

• Once installed, we recommend **ALL** instructions are kept and placed in the vehicle glove box.

**NOTE: Routine maintenance and inspection of the towbar & HITCH PIN is required. Regularly inspect for wear and check the tightness of the Hitch Pin. Follow instructions below to retighten the nut when necessary.**

**\*Do not tow with your vehicle if the R CLIP or the HITCH PIN is loose or missing. Replacement parts are available from your Pro Series Distributor.**

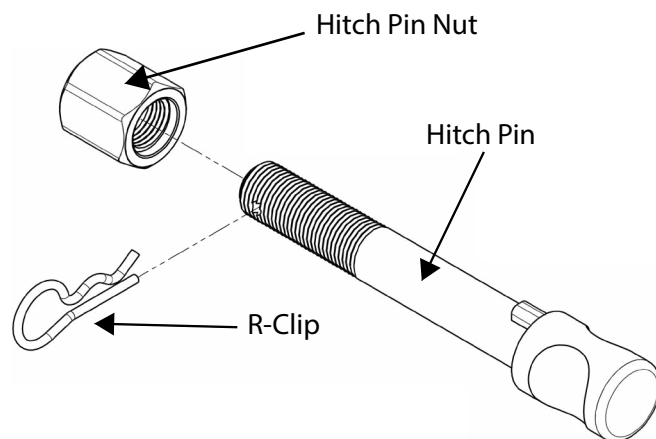

Fig 1. Silent Anti-Rattle Hitch Pin assembly

### STEP 1

Insert Trailer Ball Mount (TBM) into towbar HITCHBOX, aligning hole in TBM SHANK with hole in HITCHBOX (Fig 2).

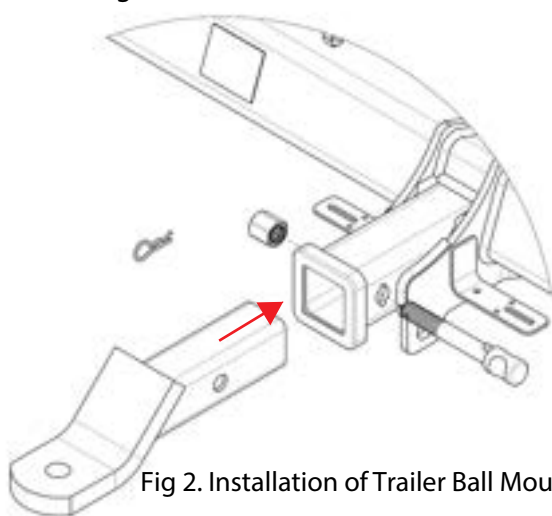

Fig 2. Installation of Trailer Ball Mount

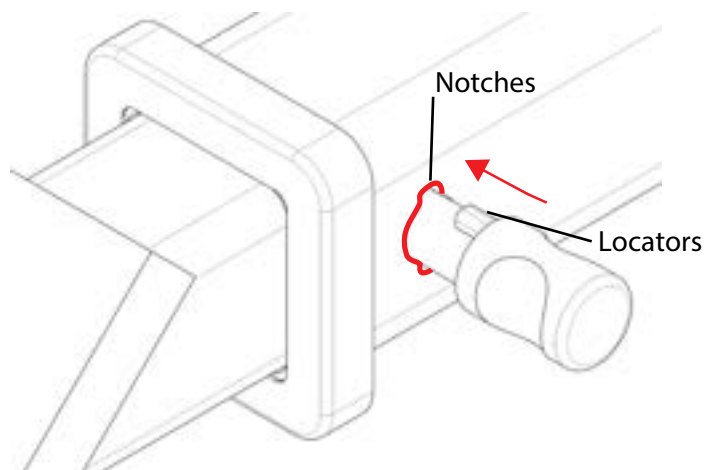

Fig 3. Silent Anti-Rattle Hitch Pin orientation

### STEP 2

Insert HITCH PIN through hole in HITCHBOX and hole in TBM SHANK; ensure the LOCATORS are inserted into the NOTCHES in the HITCHBOX (Fig. 3).

### STEP 3

Screw HITCH PIN NUT onto HITCH PIN; tighten HITCH PIN NUT until finger tight, ensuring TBM is restrained from movement.

### STEP 4

Tighten HITCH PIN NUT by turning nut a further 1/8th of a turn in the clockwise direction using a 24mm spanner (Fig. 4).

### STEP 5

Install HITCH PIN R CLIP through the hole on the HITCH PIN (Fig. 1).

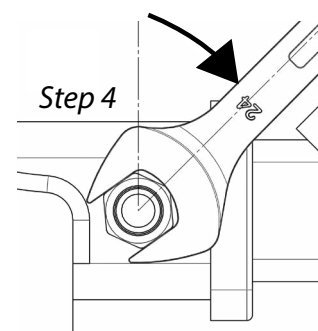

Fig 4. Tightening of Silent Anti-Rattle Hitch Pin Nut