



TOWBAR INSTALLATION INSTRUCTIONS

PART NUMBER QTMG002L

MG ZS AZS1 TOWBAR

PRODUCT DETAILS:

Part Number:	QTMG002L	Maximum Towing Braked:	500	kg
ECU Number:	04831	Maximum Towing Unbraked:	500	kg
Tail Harness Length Required:	1200mm - 04936	Maximum Static Ball Load:	50	kg
TBM/Lug Part Number:	21201			

FITTING DETAILS:

Towbar Installation Time:	60 Mins.	RPA Disable/Other:	YES
Total Installation Time:	120 Mins.		
Bumper Cut Required:	Yes		

Note:

- Electric brake input location: Near RHS tail lamp connector.
- RPA is disable via Rear Switch. Ensure the use of 04936 Tail.

TRAILBOSS RECOMMENDS THAT INSTRUCTIONS ARE READ AND UNDERSTOOD COMPLETELY PRIOR TO FITMENT.

BEFORE YOU START:

Check all hardware items have been included refer to assembly diagram.
Please ensure this towbar is only fitted to vehicle models as per Trailboss application guide.

Bumper Cuts

Vehicle and bumper variations can and do occur during vehicle manufacture after initial towbar design. Fitment of towbar to vehicle and accuracy of bumper cut must be assessed prior to any bumper modifications made. Incorrect bumper cuts are not covered under Trailboss warranty.

NOTE: Bumper cuts need to be approached with care, refer to notes below.

- Bumper centreline – where the centreline of the bumper needs to be determined, the installer must assess centre point by measurement of bumper width or determining two symmetrical reference points to give centreline.
- Bumper edge – To assist with accurate bumper cut measurement, reference to the start of the bumper edge is now being commonly used.
 - Measure from bottom edge along bumper and around corner to the 70 mm point (Figure 1).
 - Do not measure from visible bumper front of corner, upwards (Figure 2).

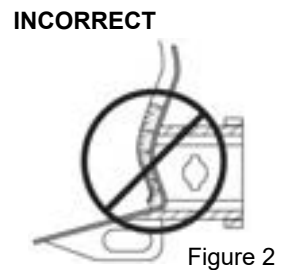
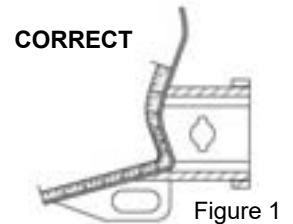

Drilling

- For any required drilling during installation, ensure that the area is clear of fuel, electrical & other components that may be damaged.
- All holes drilled into metal body panels shall have all burrs & swarf removed then coated with a suitable rust preventative paint.

Bolts/Fasteners

- Ensure that all hardware is fastened to correct torque as specified in this fitting instruction.
- All fasteners supplied with this product are used to achieve a specified clamp loading. If replacement is required ensure that fasteners of the same grade and class are used.

NOTE: Achieving correct torque is critical to proper installation and responsibility of the installer. Towbar failures attributed to tension issues from over tightening or under tightening are not covered by Trailboss warranty.

Product Labels

- a. Towbar load rating sticker provided with this product shall be conspicuously located on inside rear end of the driver's door.

WARNING:

Do not, drill, cut, weld or otherwise modify the towbar.

FOR TOWING PURPOSES ONLY - This towbar is designed and tested by Trailboss to adhere to ADR 62/02 which provides only for the expected load demands of towing.

i TOWBAR ASSEMBLY DIAGRAM

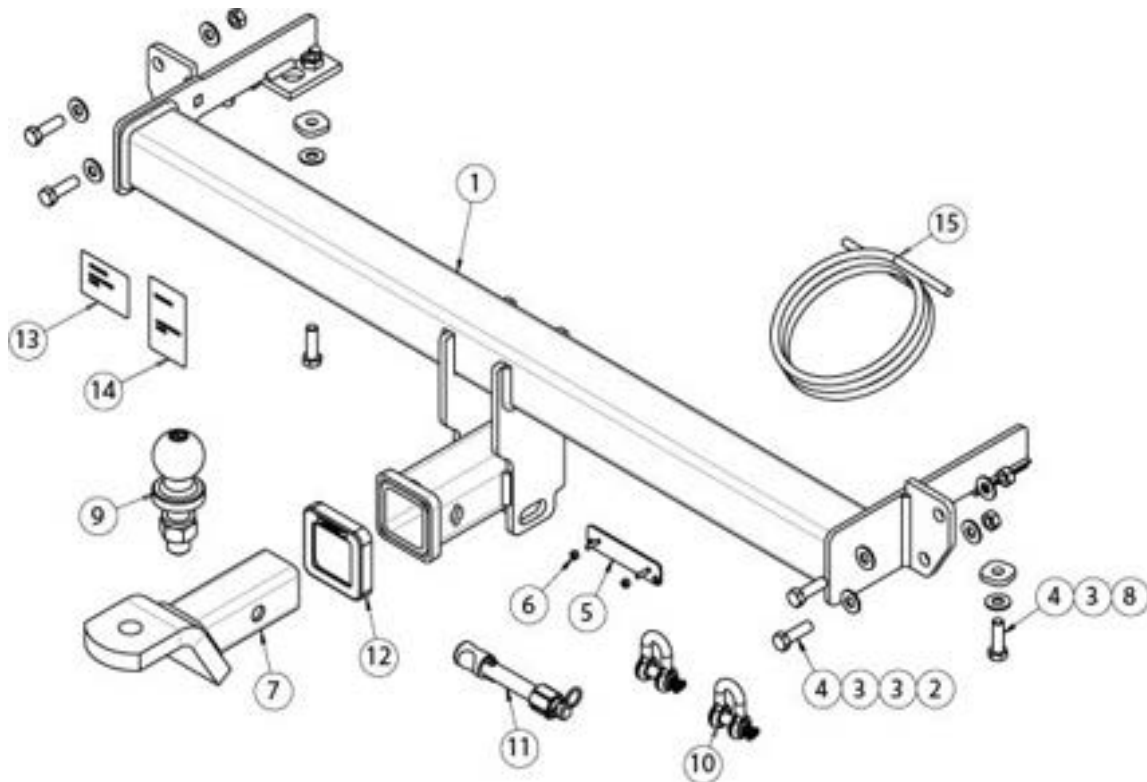

ITEM	DESCRIPTION	QTY
1	MG ZS WELDED ASSY	1
2	NUT HEX HD M10x1.5P	4
3	WASHER FLAT M10	10
4	SET SCREW HEX HD M10x35x1.5P	6
5	PLUG BRACKET	1
6	NUT NYLON LOCK HEX M4x0.7P	2
7	TRAILER BALL MOUNT	1
8	SPACER PLATE	2
9	TOWBALL 50mm	1
10	"D" SHACKLE 10mm	2
11	SMART PIN SILVER	1
12	HITCH BOX COLLAR COVER	1
13	COMPLIANCE LABEL	1
14	LOAD RATING LABEL	1
15	WIRING LOOM	1

-
1. Open tailgate and remove the plastic trim cover.

Repeat for other side.

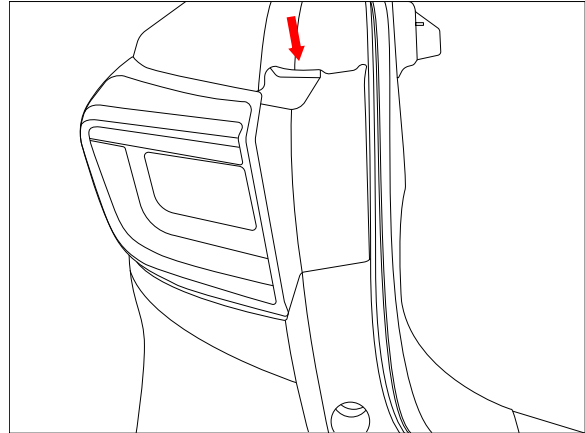

-
2. Remove the exposed 2 x bolts securing the taillight and 1 x screw securing the bumper.

Repeat for other side.

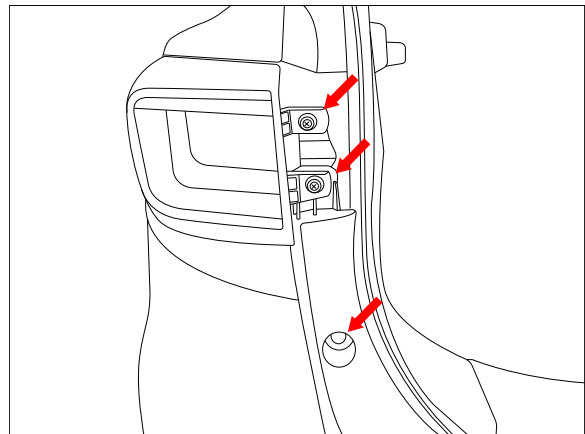

-
3. Remove taillight from vehicle (pull rearwards), disconnect wiring harness and set aside.

4. In the taillight cavity remove 1 x screw.

Repeat for other side.

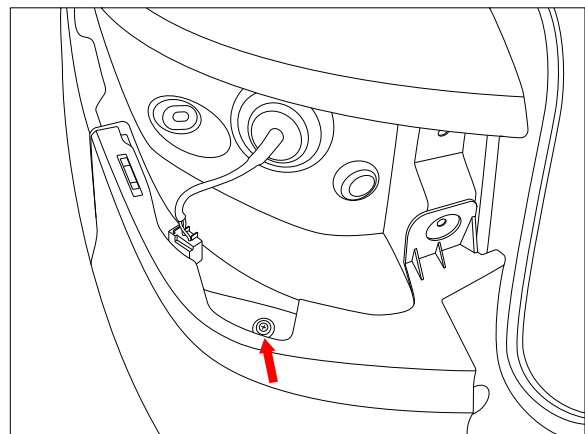

-
5. Remove 1 x screw in wheel arch.

Repeat for other side.

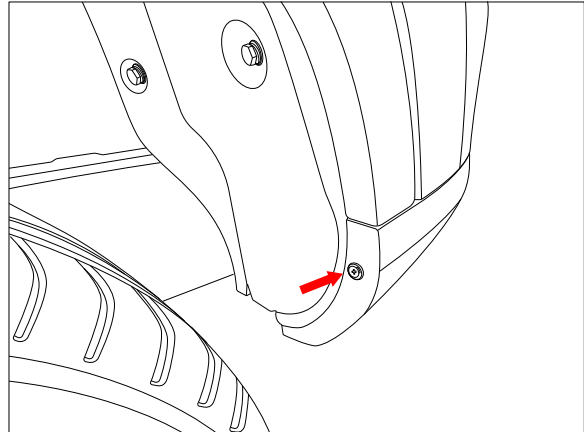

-
6. Along the underside of the bumper, remove 8 x screws.

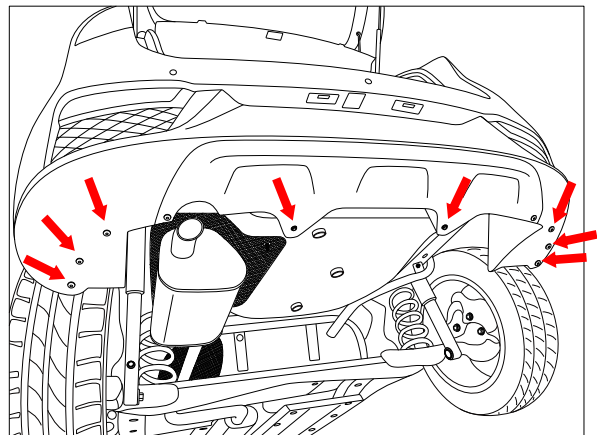

-
7. Unclip and peel away fender skirt to expose screw. Remove 1 x screw.

Repeat for other side.

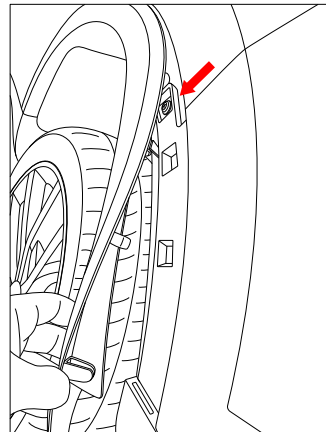

-
8. Peel away the bumper from the sides and remove from vehicle.
Ensure to disconnect all wiring and sensor connectors.

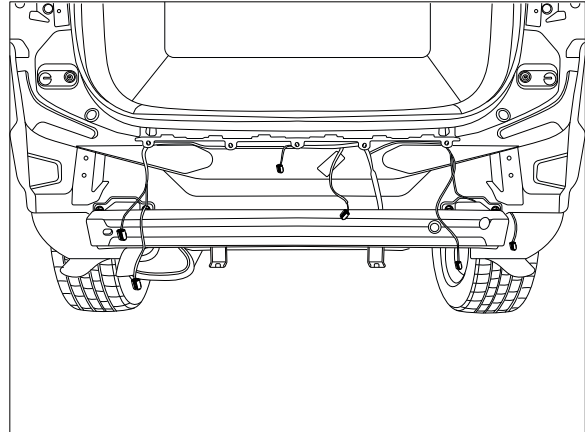

-
9. Remove impact beam secured with 8 x Nuts (4 per side). There are 4 x nuts located on the outer face and 4 x nuts located inner face of the rear panel.

Discard the impact beam and the nuts.

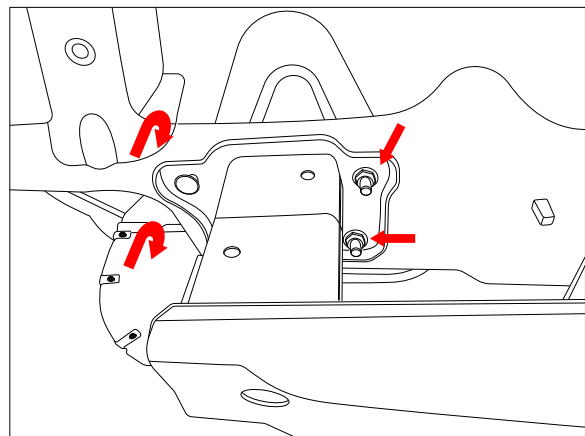

-
10. Lower exhaust by removing from the rubber hanger brackets to gain access to the heat shield.
11. Remove heat shield secured with 2 x bolts and 2 x flange nuts.

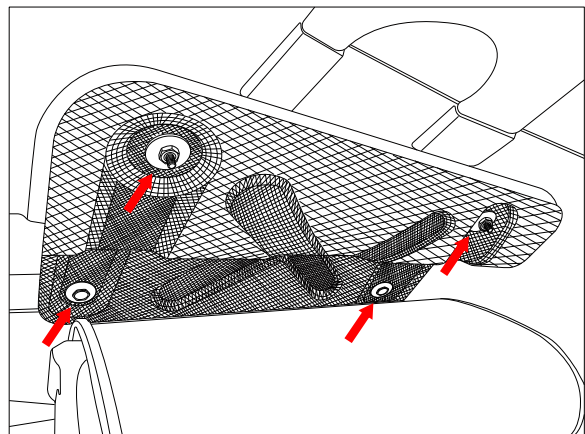

12. Fit towbar into the chassis rails of the vehicle and secure with 4 x M10 bolts complete with 2 x washers and 1 x nut per bolt on the rear panel and 2 x M10 bolts complete with 1 x spacer and 1 x washer per bolt from under the chassis rail.

Torque all fasteners to 44Nm

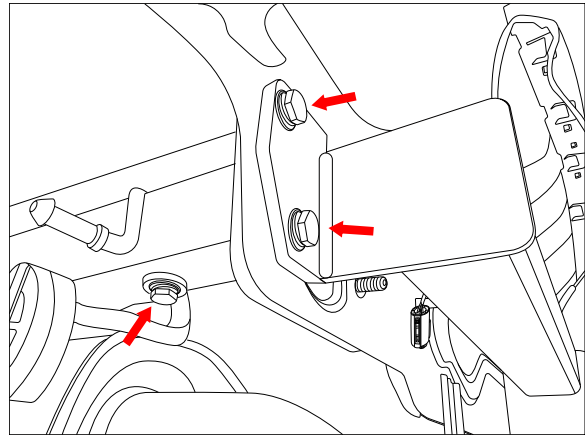

13. On the bumper determine the centre, mark and cut out a recess 80mm wide x 100mm long measured from the bottom edge of the bumper.

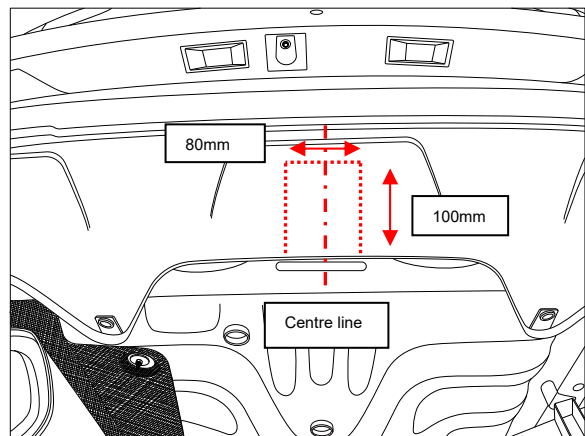

14. On the bumper, find a suitable location for the plug bracket. Mark out and drill 2x $\varnothing 5\text{mm}$ holes 69mm apart on the skin to support plug bracket.

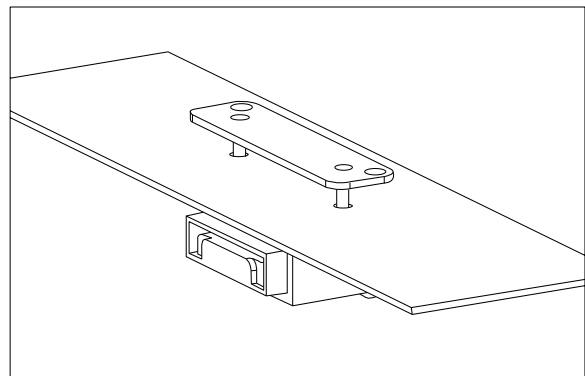

IMPORTANT

Due to possible vehicle variations, always confirm any noted vehicle colour wires with a multi-meter to ensure the correct function is identified before soldering or scotch locking. For vehicle wires denoted with two colours (example; RED/GREEN) the first colour will always be the main wire colour while the second colour is the thinner trace colour on the wire.

15. In the engine bay, disconnect the negative battery terminal (1).

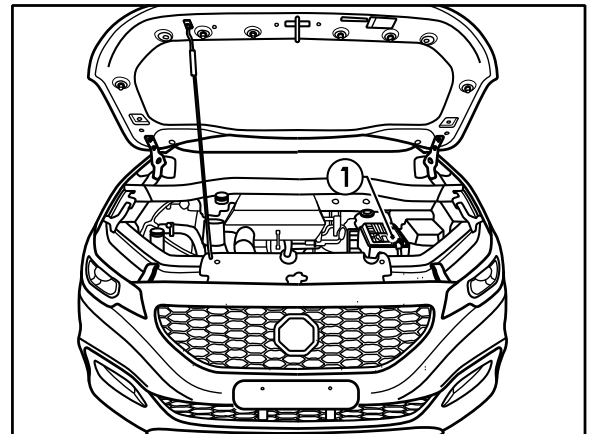

16. In the boot, remove the rear sunshade (1).

17. Remove the floor cover carpet (2).

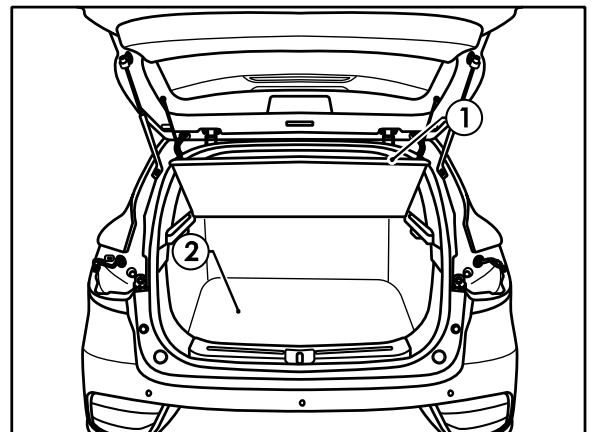

18. Remove the two phillips head screws (1) from the rear scuff trim (2).

19. Dislodge the rear scuff trim by pulling in an upwards direction.

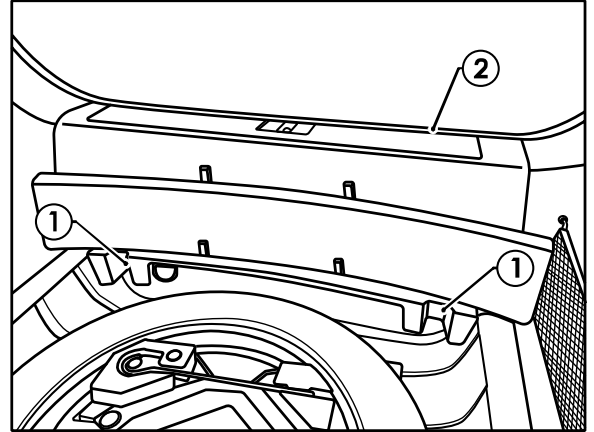

20. Inside the boot, remove the small lower RHS C pillar trim (1) near the rear seat by pulling towards the centre of the vehicle.

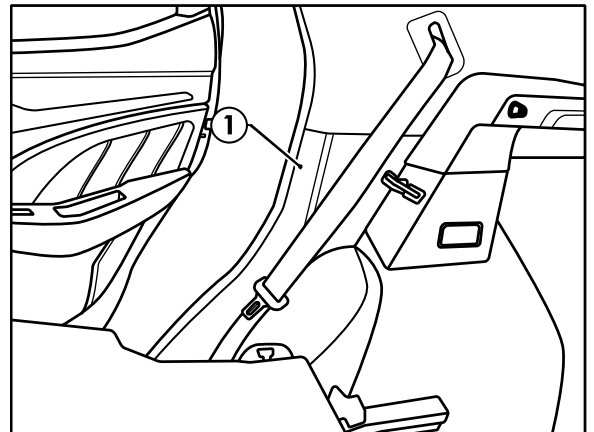

21. On the RHS C Pillar trim (1), dislodge the 3 end caps (2) covering the Phillip's head screws.

22. Remove the three Phillips head screws securing the C Pillar trim.

23. Dislodge the C pillar trim by pulling towards the centre of the vehicle.

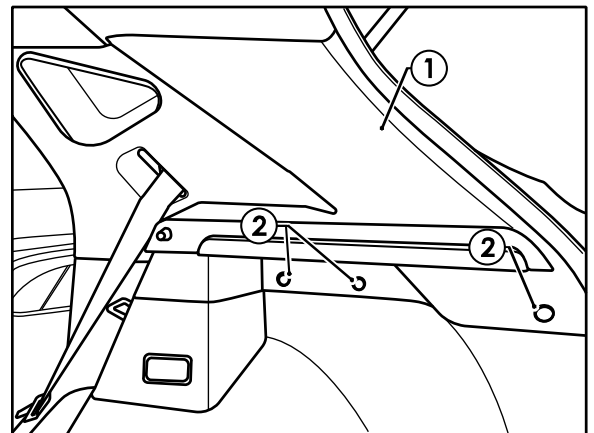

24. Disconnect the boot compartment light connector and then remove the RHS C Pillar Trim (1).

25. Fold the RHS carpet towards the centre of the vehicle to gain access to the RHS rear tail light connectors.

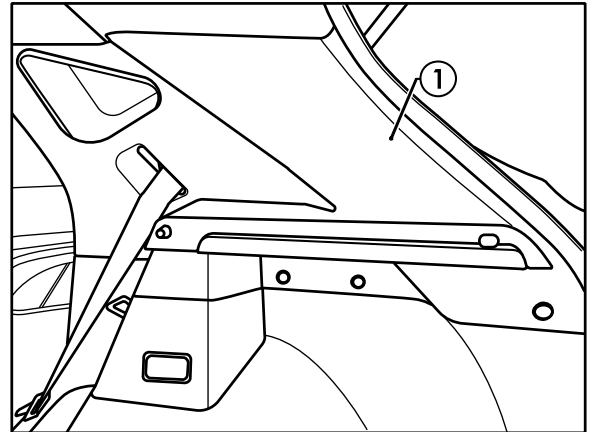

26. On the LHS C Pillar trim (1), dislodge the three end caps (2) covering the Phillip's head screws.

27. Remove the 3 screws securing the C Pillar trim.

28. Dislodge the C pillar trim by pulling towards the centre of the vehicle, but do not remove.

29. Fold the LHS carpet towards the centre of the vehicle just enough to gain hand access to the LHS rear tail light connectors.

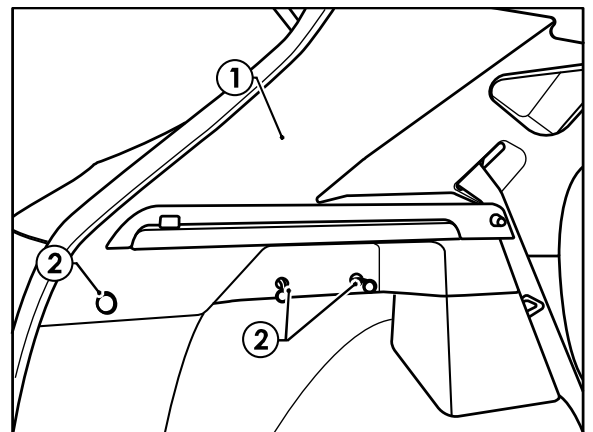

30. At the RHS tail light, push the existing vehicle grommet (1) from the outside through the grommet hole into the vehicle.

31. From the inside of the vehicle, feed the trailer patch (102067-WL) connector with grommet (2), through to the outside of the vehicle and seat the trailer patch grommet in the original hole.

Note: Ensure grommet is seated correctly and makes a good seal.

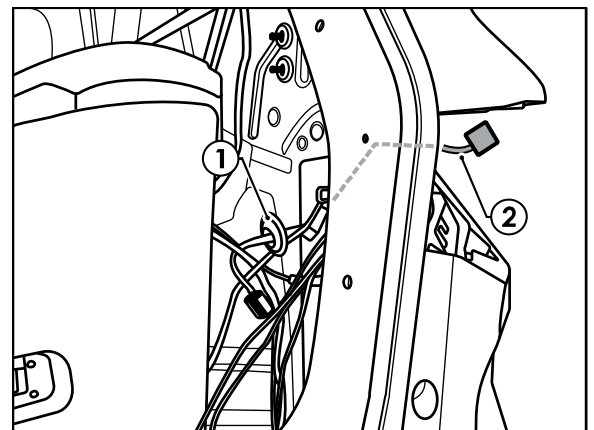

32. Connect the main vehicle harness connector (1) to the trailer patch (2).

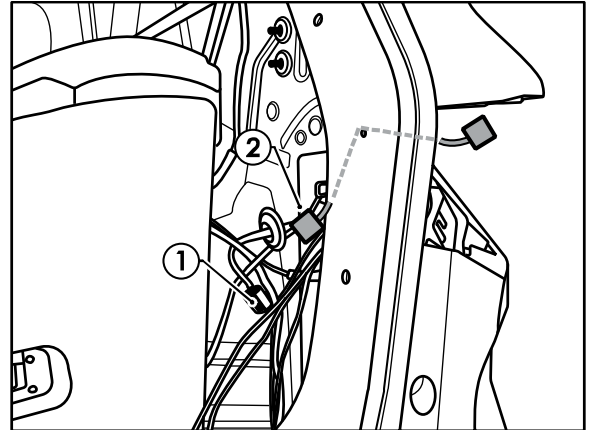

33. Connect the ground wire (1) to the vehicle earth stud (2).

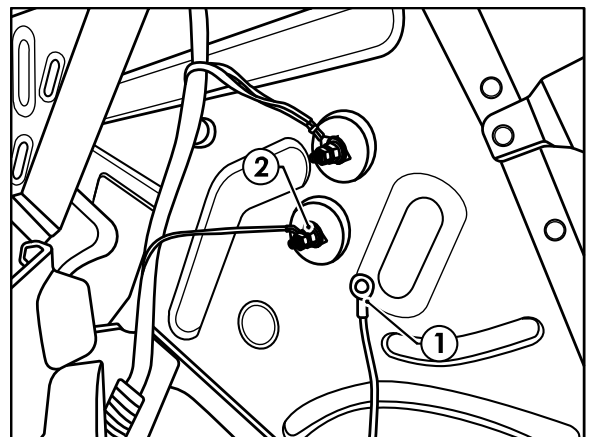

34. For auto RPA disable, patch in the RPA Disable connectors (1) to the RPA harness (2).

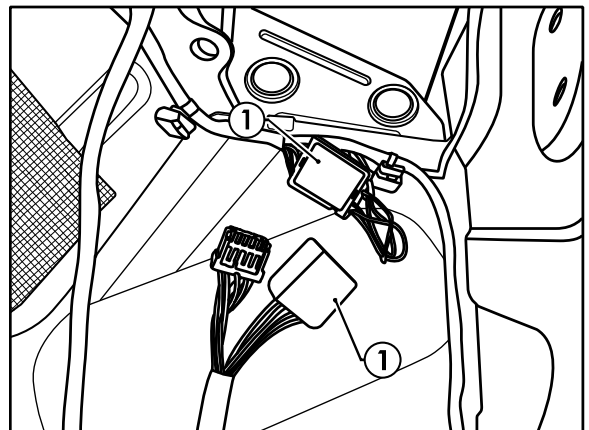

35. Using an alcohol wipe, clean the RHS inner sheet metal area (1) and the underside of the ECU (04836) (2).

36. Connect the trailer patch 12-way connector (3) to the ECU.

37. Apply double sided tape to the ECU (2) and secure it to the vehicle sheet metal.

Note: Mount the ECU, ensuring the connector is orientated downwards.

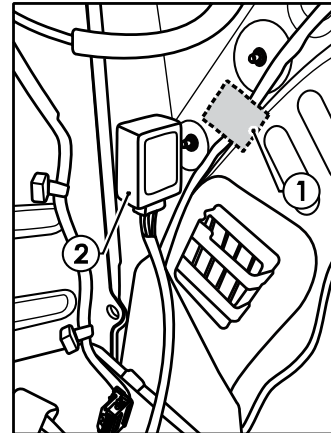

38. Route the Yellow/Black wire across to the LHS.

39. Unseat the LHS vehicle tail light grommet (1) and feed the Yellow/Black wire through the hole.

40. Before the grommet, remove a small length of anti-abrasion cloth tape, and then remove a small length of PVC tape (2).

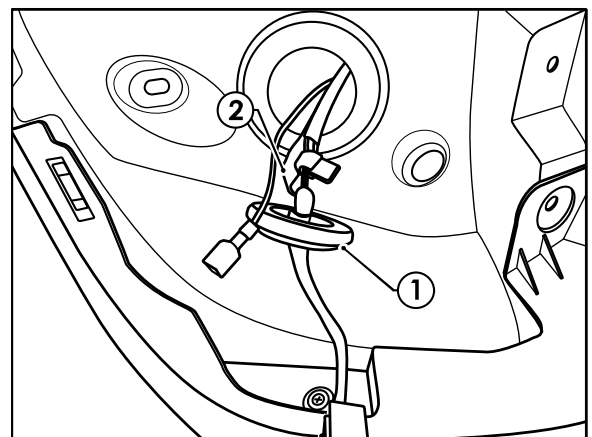

41. Following the table below, connect the ezytap (1) to the mating tail light harness wire (2). Then connect the trailer patch Yellow Black wire (3) to the correct ezy-tap.

Function	Trailer Patch	Vehicle Harness
Left Indicator	Yellow / Black	Green / Brown

Note: Test the vehicle wires first to confirm the functions.

NB: The first wire specified is the main colour the second wire is the trace colour.

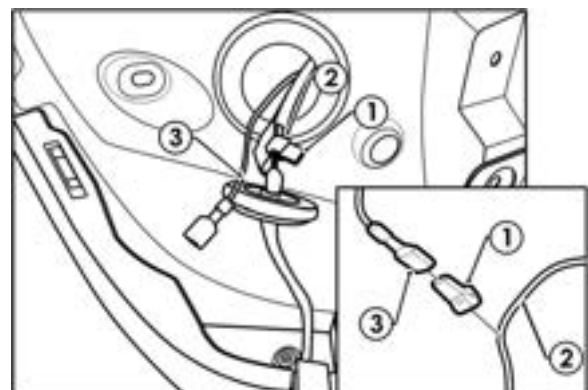

42. Route the orange power wire (1) down the RHS, tuck the power wire under all the RHS trim.
43. Route the power wire across the driver's trim towards the passenger side.
44. Continue routing to the fuse panel (2) behind the glove box.

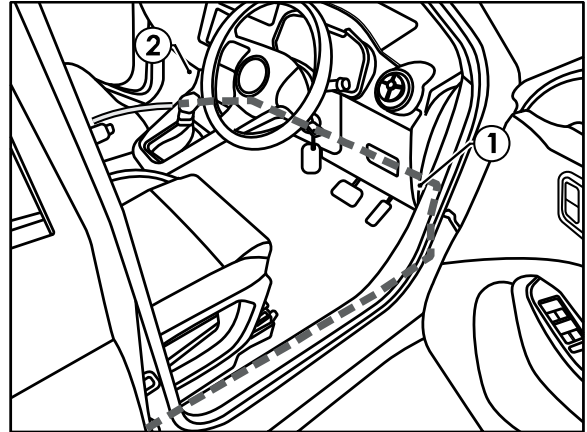

45. Remove the vehicle 20 Amp fuse (1). Insert the supplied 20 amp fuse (2) into the Add-A-Fuse (3).
46. Insert the vehicle 20 Amp fuse (1) into the other vacant slot in the Add-A-Fuse and then insert the Add-A-Fuse (3) into the original fuse location in the orientation shown.

Note: To maintain correct electrical operation, ensure you insert the fuse adaptor into the allocated slot and in the orientation shown.

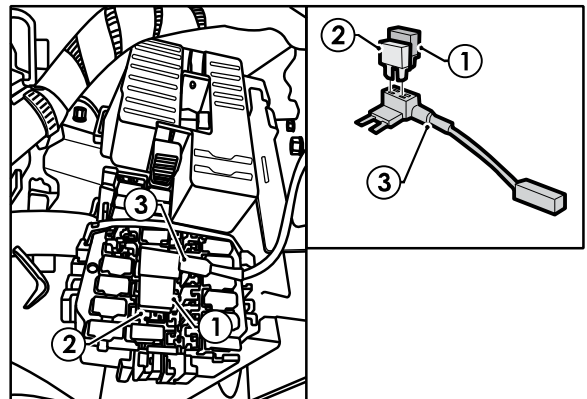

47. Connect the Add-A-Fuse (1) to the power harness (2).

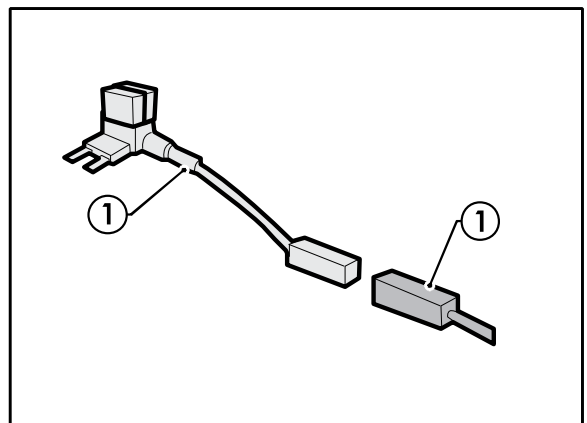

48. Remove the 25mm blank grommet (1) in the Rear RHS floor. Drill out to 30mm.
49. With the rear bumper removed, secure tail harness (04936) to towbar.
50. Route tail harness up through previously drilled hole.

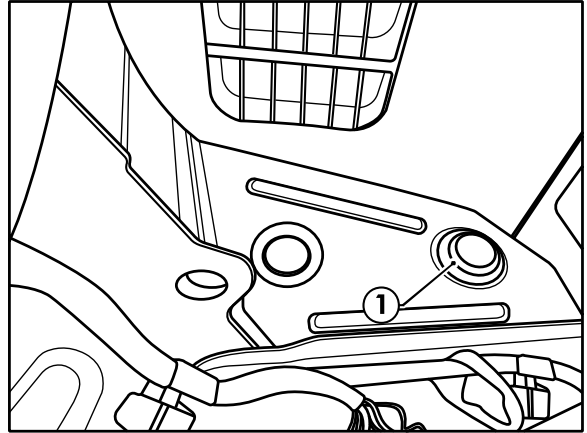

51. Seat grommet in 30mm blanking hole (1) and route to trailer harness blue connector on wiring loom.

Note: Keep harness routing clear of all sharp edges, moving parts and places of extreme heat.

Note: Ensure grommet is seated correctly and makes a good seal.

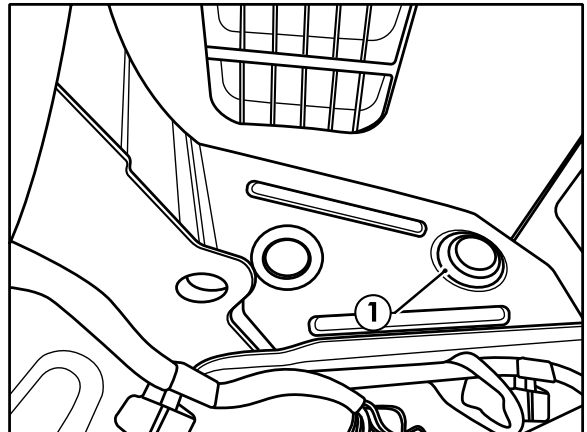

52. Connect the tail harness 8-way connector to the trailer patch mating 8-way connector.
53. Cut-off, crimp the tail harness GREY and GREY/BLACK wires (1) to the trailer patch matching WHITE and GREY/BLACK wires (2).
54. Apply silicone grease (not supplied) (5) to waterproof the blue connector.
55. Secure all harness using supplied Cable Ties.

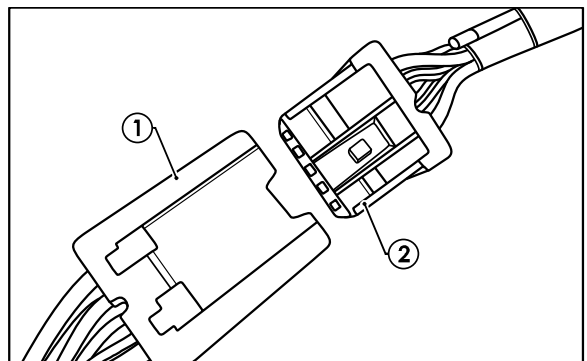

-
56. Test the trailer patch function using a light board or multi-meter.
 57. Secure all harness using cable ties (not supplied).
 58. Re-fit all removed parts and secure all fasteners, ensuring there are no squeaks or rattles.
 59. Place the fitting instructions in the glove box after fitment.
-



CUSTOMER INFORMATION

PLACE THESE INSTRUCTIONS IN THE
VEHICLE'S GLOVEBOX AFTER INSTALLATION

**THANK YOU FOR PURCHASING TRAILBOSS. WITH CORRECT MAINTENANCE AND CARE
THIS PRODUCT WILL PROVIDE A LIFETIME OF TROUBLE-FREE OPERATION.**

TOWBAR MAINTENANCE AND CARE:

1. Trailboss recommend that the towbar LUG or TBM (Trailer Ball Mount) Pull Pin and R-clip are removed and stored when not in use. Removal of LUG or TBM (Trailer Ball Mount) is advisable when not in use to assist with any of the following.
 - Ensure rear number plate is not obscured.
 - Allow maximum available departure angle and prevent any potential interference.
 - Prevent possible interference with vehicles reverse sensors or camera detecting a tow ball mount as an obstruction during reversing.
 - Removes towball mount as an obstruction for when moving around the rear of the vehicle.
2. Trailboss recommends routine inspection of your towbar to ensure trouble free towing.
 - Bolt security and tension should be regularly inspected and checked for correct tension. Replace any worn or defective parts with suitable grade & class fasteners. Inspection should be requested to coincide with vehicle major services.
3. It is the owner's responsibility to ensure towing and down ball weight capacities of the towing vehicle are not exceeded.
 - Towing and down ball weights allowable may differ according to model variations. Please refer to owner's manual or vehicle dealer to confirm exact rating for your vehicle model variant.
 - It is not uncommon for the vehicle tow rating to differ from the towbar rating. When this occurs, the lesser rating must be adhered to.
 - For vehicles fitted with enhanced vehicle functions that may be altered/changed when towing i.e Trailer sway mitigation, blind spot detection, adaptive cruise control etc. Please consult owner's manual to understand changes enabled when towing and after towing.

WARRANTY INFORMATION:

Trailboss Towbars are covered by a Lifetime Warranty.

Our goods come with guarantees that cannot be excluded under the Australian Consumer Law. You are entitled to a replacement or refund for a major failure and for compensation for any other reasonably foreseeable loss or damage. You are also entitled to have the goods repaired or replaced if the goods fail to be of acceptable quality and the failure does not amount to a major failure.

For further details please contact customer service on 1800 812 017.

PRO SERIES SILENT ANTI-RATTLE HITCH PIN

Your Trailboss towbar is equipped with a Pro Series Silent Anti-Rattle Hitch Pin technology to help reduce towbar tongue rattle in most driving conditions. Please ensure below instructions are understood and routine maintenance is carried out to ensure best towing experience.

Regularly inspect for wear and check the tightness of the Silent Anti-Rattle Hitch Pin. Follow instructions below to re-tighten the nut as necessary when movement and noise in the tow ball mount is noted.

- Before towing, ensure R-Clip is properly installed and hitch pin nut is installed and tensioned. Replacement parts are available from your Pro Series Distributor.

TOWBALL MOUNT REMOVAL/INSTALLATION

STEP 1

Insert Trailer Ball Mount (TBM) (a) into towbar hitchbox (b), aligning hole in TBM shank (c) with hole in hitchbox (d) (Fig. 1)

STEP 2

Insert Silent Anti-Rattle Hitch Pin (e) through hole in hitchbox and hole in TBM shank (g); ensure the locators are inserted into the notches in the hitchbox (Fig. 2)

STEP 3

Screw Silent Anti-Rattle Hitch Pin Nut (f) onto Smart Pin (g); tighten Smart Pin Nut until finger tight, ensuring TBM is restrained from up and down movement.

STEP 4

Tighten Silent Anti-Rattle Hitch Pin Nut by turning nut a further 1/8th of a turn in the clockwise direction using a 24mm spanner (Fig. 4).

STEP 5

Install Silent Anti-Rattle Hitch Pin R-Clip through the hole that provides best clearance or easiest access. (Fig. 5)

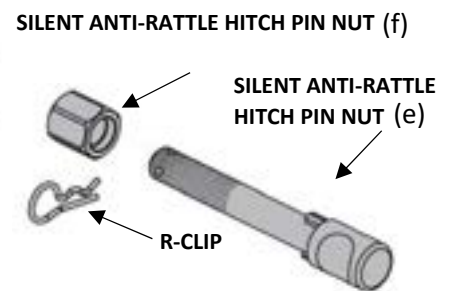
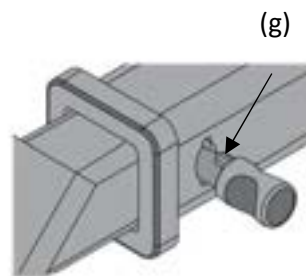
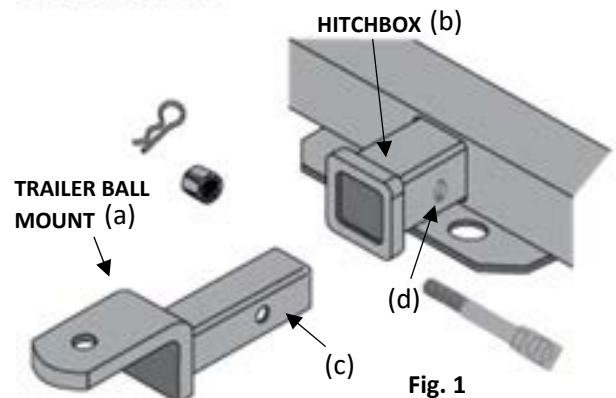

Fig. 2

Fig. 3

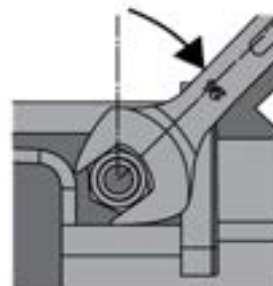

Fig. 4

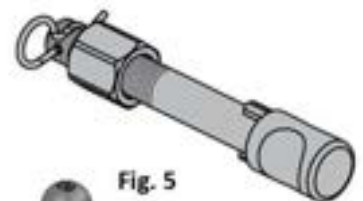

Fig. 5

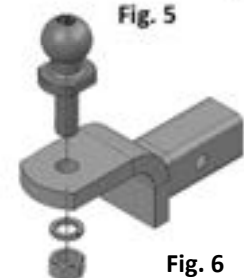

Fig. 6