

TRAILBOSS

Towbar Fitting Instructions To Suit **RENAULT TRAFIC X82** Part Number **QTRE15L** Rating **2000/200** kg

PLACE THESE INSTRUCTIONS IN THE VEHICLE'S GLOVEBOX AFTER INSTALLATION IS COMPLETED

WARNING:

1. Do not, drill, cut, weld or otherwise modify the tow bar.
2. If you are using electric welding on a motor vehicle, **always** check that the vehicle is not equipped with electronic engine or instrument management equipment. Failure to do so could **destroy** any onboard computers. If in doubt, check with the vehicle's manufacturer.
3. The high tensile fasteners supplied with this product were used to achieve the specified rating. If replacement is required ensure that fasteners of the same rating & quality are used. Contact an authorised **Trailboss** dealer if further information is required.
4. If TBM is used in inverted position tow ball may make contact with rear tailgate when lowered, which could cause damage.

General:

1. Ensure all hardware items have been included refer to assembly diagram.
2. It is recommended that the instructions are read through and completely understood before making any attempt to fit this product.
3. Be wary of any changes to vehicle designs or other accessories that may conflict with the installation of this product.
4. Before drilling ensure that the area is clear of fuel, electrical & other components.
5. All holes drilled into the body panels shall have all burrs & swarf removed then coated with a suitable rust preventative paint.
6. For vehicles that require the bumper to be cut. Ensure cut out area is in correct position on the vehicle prior to cutting the bumper.
7. The high tensile fasteners supplied with this product were used to achieve the specified rating. If replacement is required ensure that fasteners of the same rating & quality are used. Contact an authorized **Trailboss** dealer if further information is required.
8. Ensure that all hardware is fastened to torque list below check fasteners on regular basis.
9. Tow bar load rating sticker provided with this product shall be conspicuously located on inside rear end of the driver's door. **(See diagram below).**
10. Trailboss recommends that you check your tow ball to ensure that it complies with the Australian standards **AS 4177.2**.
11. **PLEASE NOTE:** It is advised to remove your lug or tbm when not actually towing so as to produce a clear view of the vehicles registration plate if obscured, and to also provide maximum available departure angle
12. Pull Pin must be fit in down position.

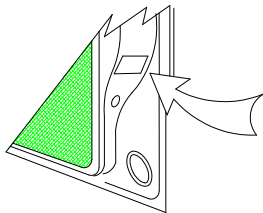

Place load rating sticker
inside driver's door here

FOR TRAILER TOWING PURPOSES ONLY
For towing capacity details please refer to vehicle owner's manual or to the manufacturer. Overloading can void your warranties.

RECOMMENDED ASSEMBLY TORQUE LISTING

Diameter	Grade 8.8 Bolt
M6	9.5 Nm
M8	21.7 Nm
M10	43.4 Nm
M12	77.3Nm
M14	146 Nm
M16	189.8 Nm

Tow bar Maintenance and Care.

Trailboss recommends that bolt torque's, as listed below, are routinely and regularly inspected and checked for correct tension. Replace any worn or defective parts.

We recommended to remove Tow Ball Mounts (TBM's, tongues or lugs) when not being used for any considerable length of time.

So as to avoid injury, when not towing it is suggested that the tongue, Pull Pin and R-clip are removed then stored in a safe, clean and dry place, away from excessive moisture.

Hitch Pull Pins and spring "R" clips are regularly checked for proper installation. Replace any worn or defective parts.

TRAILBOSS

Towbar Fitting Instructions
 To Suit **RENAULT TRAFIC X82**
 Part Number **QTRE15L**
 Rating **2000/200 kg**

PLACE THESE INSTRUCTIONS IN THE VEHICLE'S GLOVEBOX AFTER INSTALLATION IS COMPLETED

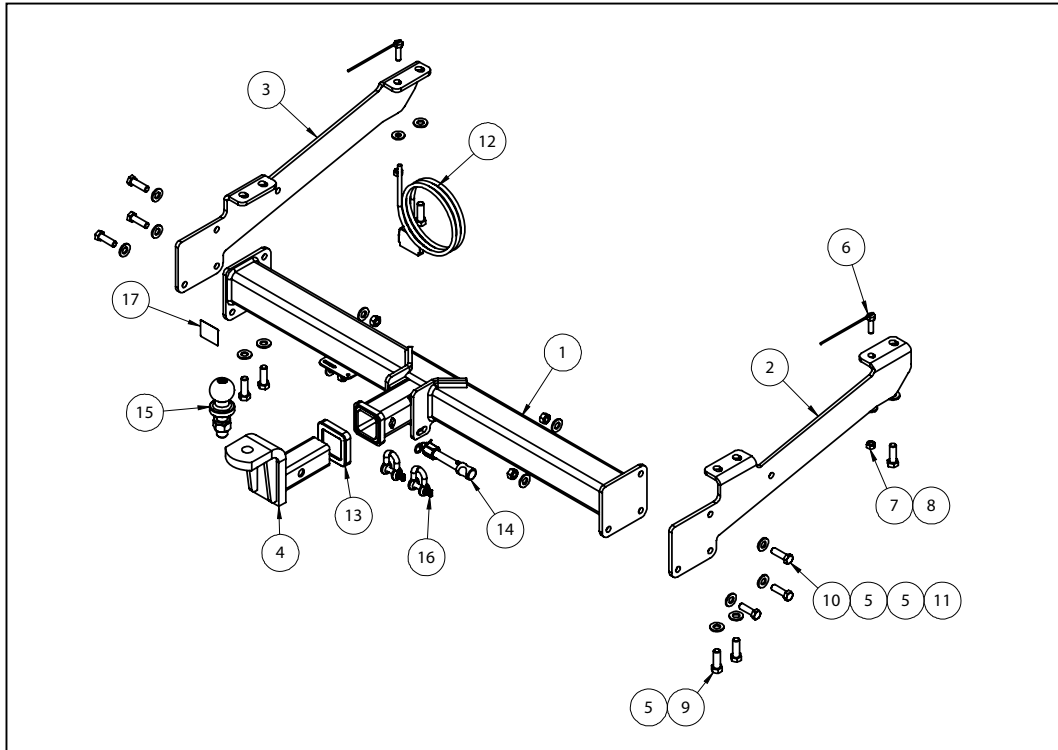

QTY.	DESCRIPTION	ITEM NO.
1	WELDED ASSEMBLY	1
1	RHS SIDE PLATE	2
1	LHS SIDE PLATE	3
1	TBM ASSY	4
18	FT WASHER M14x28x3 Z/P	5
2	WIRE & BOLT M10x35	6
2	HEX NUT M10x1.5	7
2	WASHER FT M10x25.4x3	8
6	BOLT M14-1.5x40 Z/P	9
6	BOLT M12-1.25x40	10
6	HEX NUT M12x1.25 PC8	11
1	WIRING LOOM	12
1	HITCH BOX COLLAR COVER	13
1	SILENT HITCH PIN - SILVER	14
1	50mm TOWBALL	15
2	10mm "D" SHACKLE	16
1	COMPLIANCE PLATE	17



Towbar Fitting Instructions
To Suit **RENAULT TRAFIC X82**
Part Number **QTRE15L**
Rating **2000/200** kg

PLACE THESE INSTRUCTIONS IN THE VEHICLE'S GLOVEBOX AFTER INSTALLATION IS COMPLETED

INSTRUCTION:

1. Loosely secure Side Plate to underside of chassis rail using 3x M14x40 Bolts, complete with 1x Flat Washer per Bolt.

Repeat for opposite side of vehicle.
2. Feed 1x M10x35 Bolt on wire into cutout in chassis rail, and loosely secure Side Plate to underside of chassis rail using 1x Flat Washer and 1x M10 Nut.

Repeat for opposite side of vehicle.
3. Loosely secure Towbar Assembly to Side Plates using 6x M12x40 Bolts (3 per side), complete with 2x Flat Washers and 1x M12 Nut per Bolt.
4. If installing HLP kit, secure HLP bracket to outer face of Side Plate, using Towbar Assembly fasteners.





Wiring Loom Fitting Instructions
To Suit Renault Trafic X82
Part Number 101398-WL

Wiring Loom Installation Instructions

Renault Trafic X82
Part No: 101398-WL
ECU Required: 04826

Tail Harness Length Required: 1800mm

Wiring Loom Installation Time: Approx 60 Mins

 Important	Due to possible vehicle variations, always confirm any noted vehicle colour wires with a multi-meter to ensure the correct function is identified before soldering or scotch locking.
 Important	For vehicle wires denoted with two colours (example: RED/GREEN) the first colour will always be the main wire colour while the second colour is the thinner trace colour on the wire.



Wiring Loom Fitting Instructions
To Suit Renault Trafic X82
Part Number 101398-WL

1. At the rear of the vehicle, open the cargo doors and remove the RHS tail light assembly by removing the three torx screws. **Repeat for the LHS.**
2. Remove the LHS reverse lamp assembly by removing the two screws.
3. Inside the reverse lamp cavity, drill a Ø30mm hole above the reverse lamp harness grommet. Apply rust inhibitor (not supplied) after drilling.
4. Inside the LHS rear of the cargo area, remove the LHS rear pillar trims and the upper LHS corner trim.
5. Secure the trailer patch ground ring terminal to the vehicle grounding point using the existing fastener.
6. Route the trailer patch down the LHS rear pillar (do not route the 1-way connector branch down the rear pillar) and from the exterior of the vehicle, pull out the LHS tail light harness for easier access.
7. 7. Following the table below, connect the ezy-taps to the corresponding vehicle wires (before the grommet), then connect the trailer patch terminal to the ezy-taps.

Note: Multiple wires on the connector have the same colours. Use a multi-meter to determine the correct wire function.

Note: Indicators and brakes only work when the vehicle is on.

Function	Trailer Patch	Vehicle Connector
L IND	YELLOW / BLACK	GREY
BRAKES	RED / BLACK	GREY
TAILS	BROWN / BLACK	PINK

8. At the bottom of the LHS rear pillar, from the interior of the vehicle, pull out the reverse light harness for easier access and following the table below, connect the ezy-tap to the corresponding vehicle wire (before the grommet), then connect the trailer patch terminal to the ezy-tap.

Note: Multiple wires on the connector have the same colours. Use a multi-meter to determine the correct wire function.

Note: Indicators and brakes only work when the vehicle is on.

Function	Trailer Patch	Vehicle Connector
REVERSE	BLACK / WHITE	GREY

9. Connect the trailer patch ECU connector to the ECU (P/No: 04826) and then secure the ECU onto the vehicle harness using a cable tie (not supplied).
10. Route the trailer patch across the top of the rear cargo channel, towards the RHS tail light area.
11. Remove the two tail light vents and route the trailer patch down the RHS rear pillar cavity.

TRAILBOSS

Wiring Loom Fitting Instructions To Suit Renault Trafic X82 Part Number 101398-WL

12. From the exterior of the vehicle, locate and pull out the RHS tail light harness and from following the table below, connect the ezy-tap to the corresponding vehicle wire colour (before the grommet), then connect the trailer patch terminal to the ezy-tap.

Function	Trailer Patch	Vehicle Connector
R.IND	GREEN / BLACK	GREEN

13. On the LHS of the cargo hold, dislodge the upper trims all the way to the bulk head and route the 1-way connector branch along the LHS of the vehicle and through to the front cabin.
14. Dislodge the front passenger weather seal and continue to route the trailer patch harness down to the glove compartment area.
15. Open the glove box and gain access to the fuse panel junction.
16. Remove the indicated vehicle fuse (1) (if applicable). Insert the vehicle fuse (1) and the supplied 25A fuse (2) to the add-a-fuse harness (3) as shown. Connect the trailer patch 1-way connector (4) to the add-a-fuse harness (3). Insert the add-a-fuse harness (5) to the previously removed fuse location.

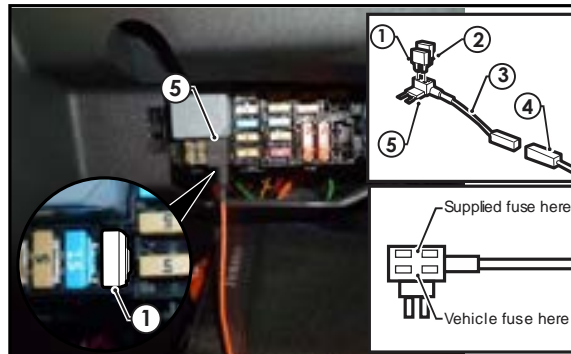

17. At the rear exterior of the vehicle, mount the tail harness socket to the towbar mounting bracket using M4 fasteners (not supplied).
18. Route the tail harness (tail length: 1800mm) across the LHS and up into the drilled out hole. Adjust the trailer patch harness grommet so that it is seated correctly and cable tie (not supplied) in place.
19. Connect the tail harness 8-way connector to the trailer patch 8-way mating connector.
20. Re-fit tail lights.
21. Test the trailer patch function using a light board or multimeter.
22. Secure all harnesses using cables ties (not supplied).
23. Re-fit all removed parts and secure all fasteners, ensuring there are no squeaks or rattles.
24. Place the instructions in the glove box after fitment.



FITTING INSTRUCTIONS

Silent Anti-Rattle Hitch Pin (PR0001)

• These fitting instructions are supplied to ensure understanding of how the HITCH PIN should be fitted and used correctly.

• Once installed, we recommend **ALL** instructions are kept and placed in the vehicle glove box.

NOTE: Routine maintenance and inspection of the towbar & HITCH PIN is required. Regularly inspect for wear and check the tightness of the Hitch Pin. Follow instructions below to retighten the nut when necessary.

***Do not tow with your vehicle if the R CLIP or the HITCH PIN is loose or missing. Replacement parts are available from your Pro Series Distributor.**

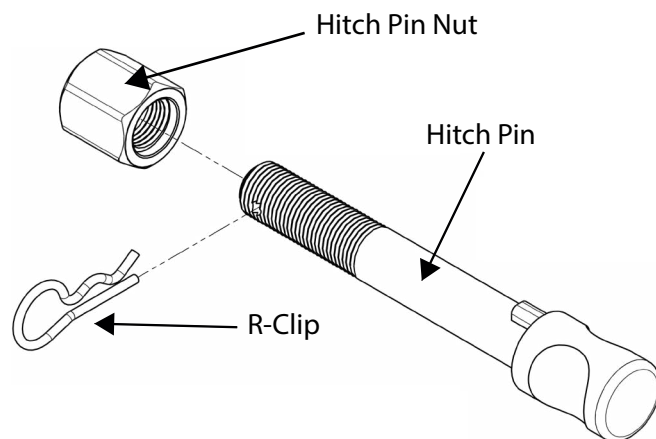

Fig 1. Silent Anti-Rattle Hitch Pin assembly

STEP 1

Insert Trailer Ball Mount (TBM) into towbar HITCHBOX, aligning hole in TBM SHANK with hole in HITCHBOX (Fig 2).

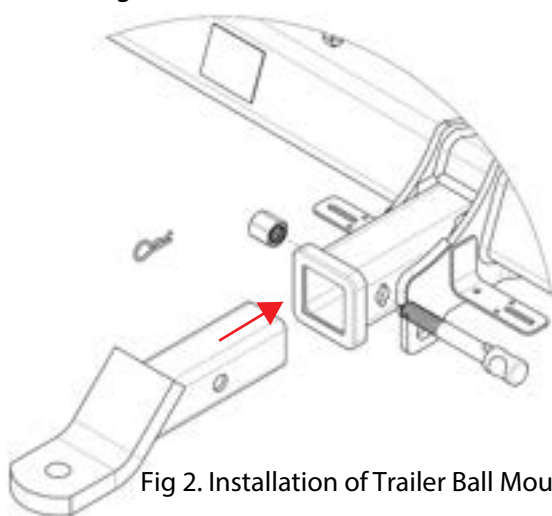

Fig 2. Installation of Trailer Ball Mount

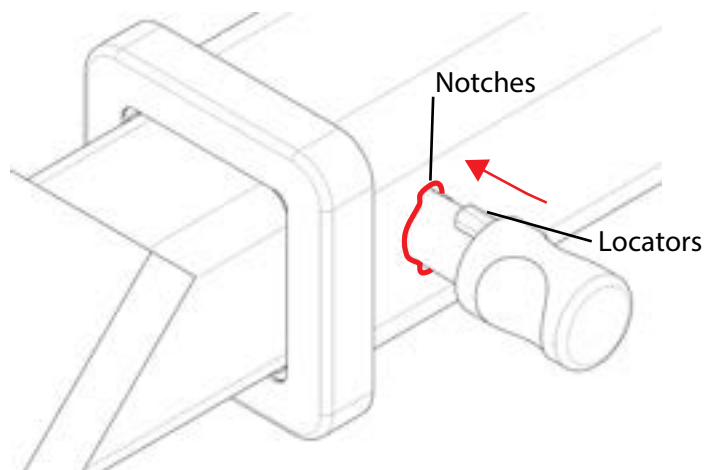

Fig 3. Silent Anti-Rattle Hitch Pin orientation

STEP 2

Insert HITCH PIN through hole in HITCHBOX and hole in TBM SHANK; ensure the LOCATORS are inserted into the NOTCHES in the HITCHBOX (Fig. 3).

STEP 3

Screw HITCH PIN NUT onto HITCH PIN; tighten HITCH PIN NUT until finger tight, ensuring TBM is restrained from movement.

STEP 4

Tighten HITCH PIN NUT by turning nut a further 1/8th of a turn in the clockwise direction using a 24mm spanner (Fig. 4).

STEP 5

Install HITCH PIN R CLIP through the hole on the HITCH PIN (Fig. 1).

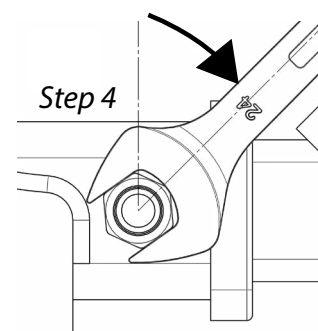

Fig 4. Tightening of Silent Anti-Rattle Hitch Pin Nut