

PRODUCT DETAILS:

Part Number:	QTRE17L	Maximum Towing Braked:	900	kg
ECU Number:	04826	Maximum Towing Unbraked:	715	kg
Tail Harness Length Required:	400 mm	Maximum Static Ball Load:	75	kg
TBM/Lug Part Number:	21331			

FITTING DETAILS:

Towbar Installation Time:	70 Mins.	RPA Disable/Other:	NO
Total Installation Time:	120 Mins.		
Bumper Cut Required:	Yes		

Note:

- RPA Disable via infotainment.

TRAILBOSS RECOMMENDS THAT INSTRUCTIONS ARE READ AND UNDERSTOOD COMPLETELY PRIOR TO FITMENT.

BEFORE YOU START:

Check all hardware items have been included refer to assembly diagram.
Please ensure this towbar is only fitted to vehicle models as per Trailboss application guide.

Bumper Cuts

Vehicle and bumper variations can and do occur during vehicle manufacture after initial towbar design. Fitment of towbar to vehicle and accuracy of bumper cut must be assessed prior to any bumper modifications made. Incorrect bumper cuts are not covered under Trailboss warranty.

NOTE: Bumper cuts need to be approached with care, refer to notes below.

- Bumper centreline – where the centreline of the bumper needs to be determined, the installer must assess centre point by measurement of bumper width or determining two symmetrical reference points to give centreline.
- Bumper edge – To assist with accurate bumper cut measurement, reference to the start of the bumper edge is now being commonly used.
 - Measure from bottom edge along bumper and around corner to the 70 mm point (Figure 1).
 - Do not measure from visible bumper front of corner, upwards (Figure 2).

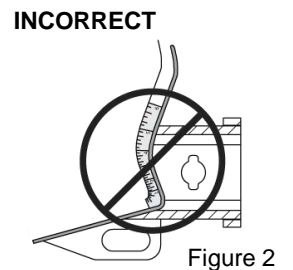
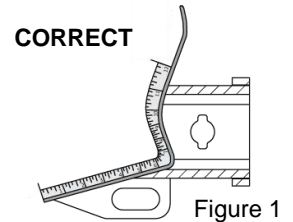

Drilling

- For any required drilling during installation, ensure that the area is clear of fuel, electrical & other components that may be damaged.
- All holes drilled into metal body panels shall have all burrs & swarf removed then coated with a suitable rust preventative paint.

Bolts/Fasteners

- Ensure that all hardware is fastened to correct torque as specified in this fitting instruction.
- All fasteners supplied with this product are used to achieve a specified clamp loading. If replacement is required ensure that fasteners of the same grade and class are used.

NOTE: Achieving correct torque is critical to proper installation and responsibility of the installer. Towbar failures attributed to tension issues from over tightening or under tightening are not covered by Trailboss warranty.

Product Labels

- a. Towbar load rating sticker provided with this product shall be conspicuously located on inside rear end of the driver's door.

WARNING:

Do not, drill, cut, weld or otherwise modify the towbar.

FOR TOWING PURPOSES ONLY - This towbar is designed and tested by Trailboss to adhere to ADR 62/02 which provides only for the expected load demands of towing.

i TOWBAR ASSEMBLY DIAGRAM

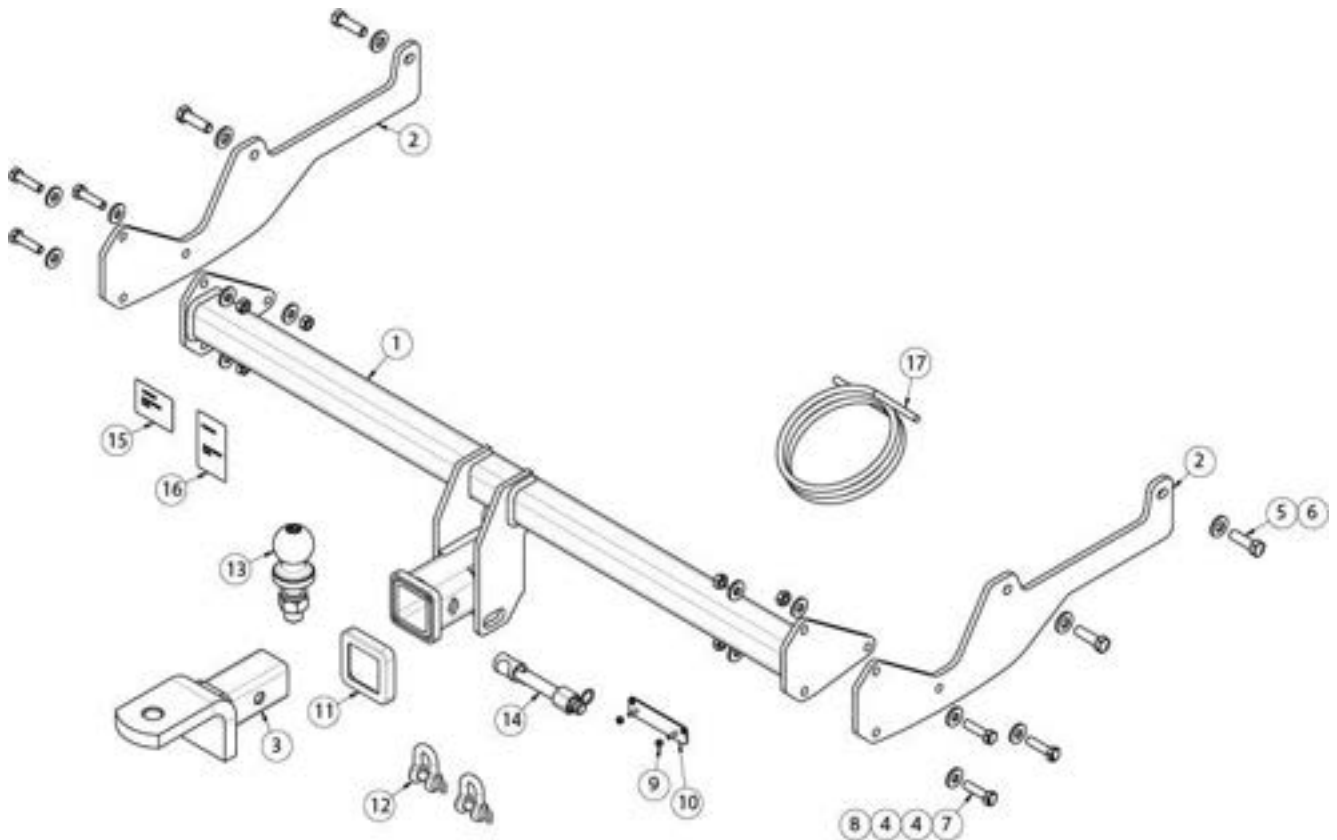

ITEM	DESCRIPTION	QTY
1	ARKANA CROSSTUBE ASSY	1
2	SIDE ARM	2
3	TRAILER BALL MOUNT	1
4	WASHER PLAIN M10x25x3	12
5	SET SCREW HEX HD M12x40x1.75P	4
6	WASHER PLAIN 1/2"	4
7	BOLT HEX HD M10x40x1.25P	6
8	NUT HEX HD M10x1.25P	6
9	NUT NYLOC HEX HD M4x0.7P	2

ITEM	DESCRIPTION	QTY
10	PLUG BRACKET	1
11	HITCH BOX COLLAR COVER	1
12	"D" SHACKLE 10mm	2
13	TOWBALL 50mm	1
14	SMART PIN SILVER	1
15	COMPLIANCE LABEL	1
16	LOAD RATING LABEL	1
17	WIRING LOOM	1

1. Open tailgate and remove the 2 x bumper screws and the 2 x Tailgate stoppers.

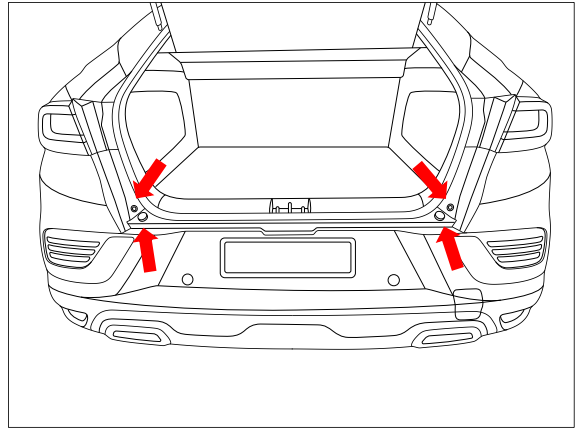

2. Remove the side trim cover from the luggage compartment interior to access the taillight mounting stud.

Repeat for other side.

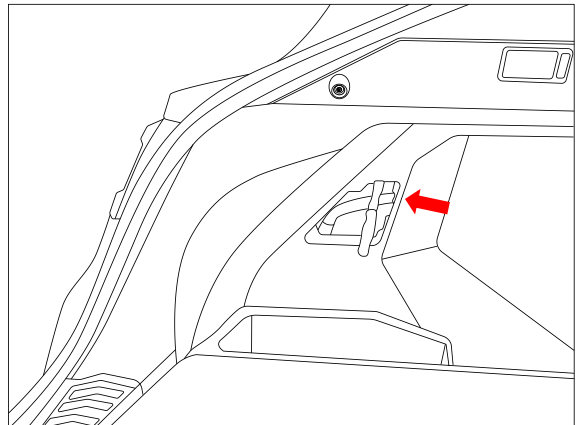

3. Remove taillight secured with 1 x nut (on stud) and unplug the wiring harness.

Repeat for other side.

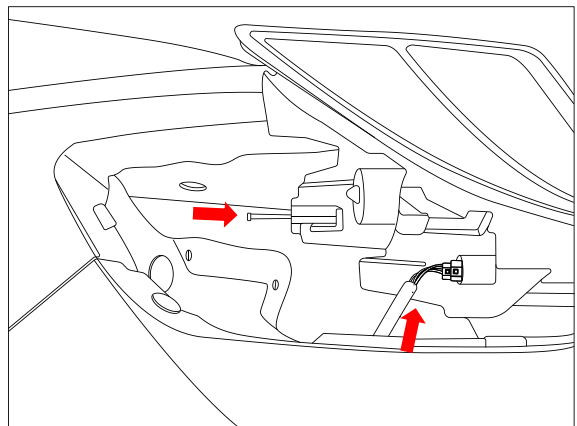

-
4. In the taillight cavity, remove 2 x scrivets from the bumper.

Repeat for other side.

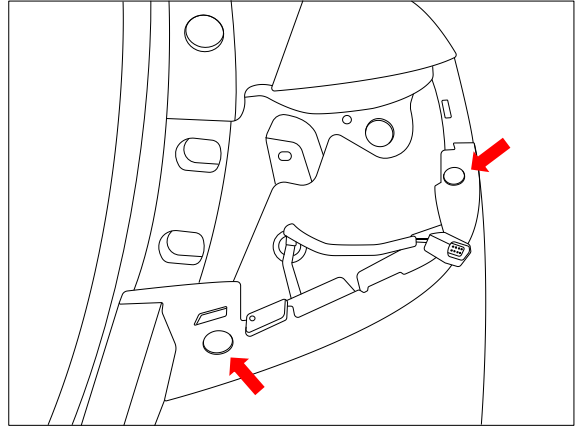

-
5. In the wheel arch, remove 1 x torx and 1 x scrivet.

Repeat for other side.

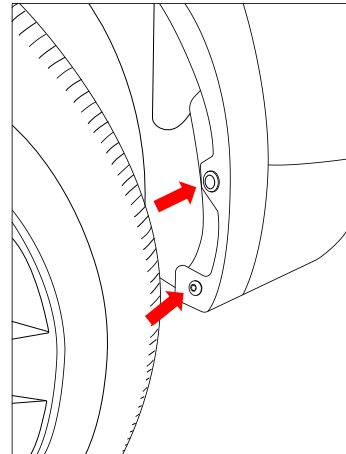

-
6. Under bumper on the LH side, remove 2 x torx and 2 x scrivets

Repeat for other side.

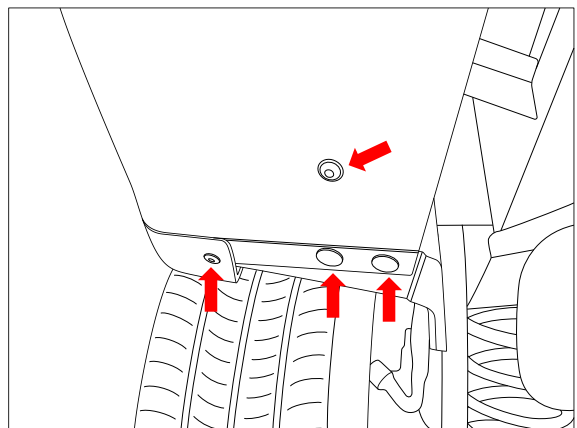

-
7. Along the underside of the bumper remove 5 x scrivenets and 2 x Torx.

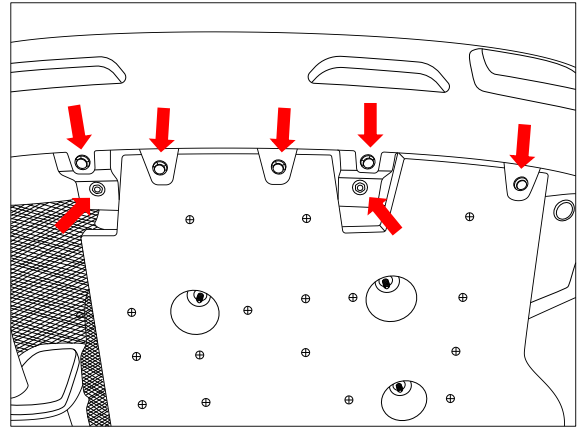

-
8. Unclip and peel away the wheel skirting from the bumper to expose the bumper screw.
To assist with this step, the retaining clips can be accessed from the inside of the bumper.
9. Remove 1 x bumper screw

Repeat for other side.

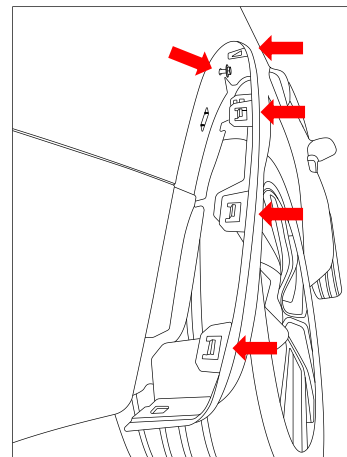

-
10. Peel away bumper from the sides and remove from vehicle. Ensure to disconnect the 2x harness plugs located on the LH side.

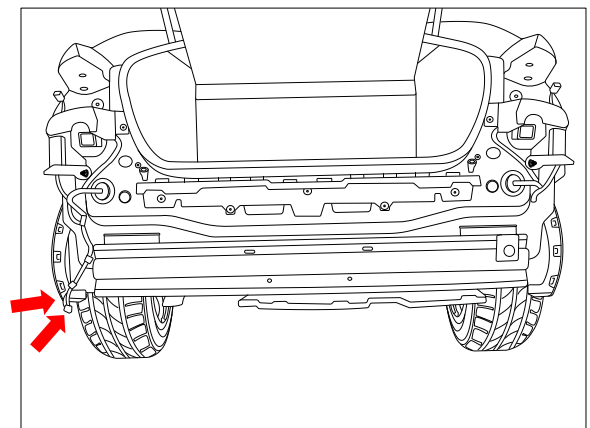

-
11. Remove and discard the impact beam secured with 3 x bolts per side.
Break the sealant so that the impact beam can be lifted up and out as there is a hook on the impact beam located by the circle.

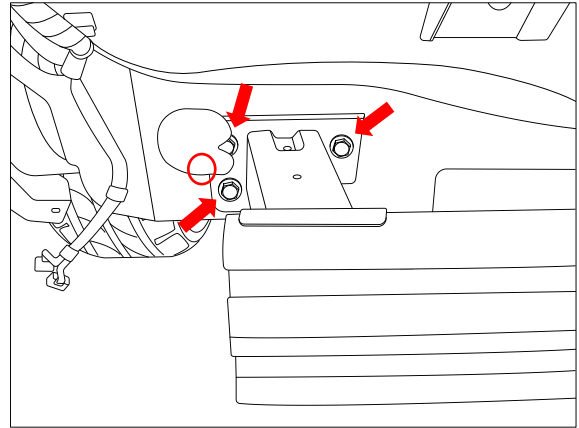

-
12. On the outside of the chassis rail, remove 2 x aluminium caps to reveal the chassis weld nuts.

Repeat for other side.

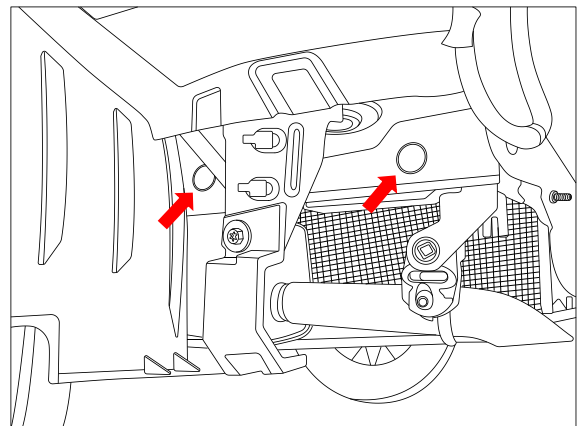

-
13. Remove excess sealant from the chassis rail to ensure the side arms sit flush on the chassis rail

14. Position the side arm to the chassis rail and loosely secure with 2 x M12 bolts complete with 1 x washer per bolt.

Repeat for other side.

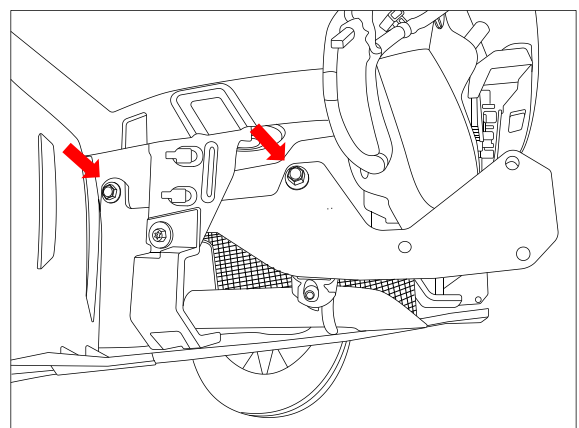

15. Position the crosstube assembly up to the side arms and loosely secure with 3 x M10 bolts per side complete with 2 x washers and 1 x nut per bolt.

Tighten all fasteners to the following torque:

M10 x 1.25 Gr10.9 : 68Nm

M12 x 1.75 Gr10.9 : 109Nm

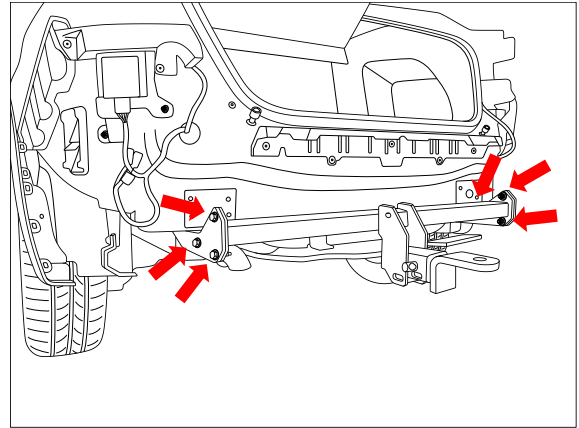

16. For the bumper cut.

Identify the centre line of the bumper. Measure, mark out and cut a section 120mm long from the bottom edge of the bumper (follow bumper profile) and 90mm wide (45mm either side of the bumper centreline).

NOTE: Ensure you do not cut through any wiring or sensors (footswipe sensors) located on the inside of the bumper.

The key antenna may be required to be relocated to the side and clamping it with a single screw and cable tie.

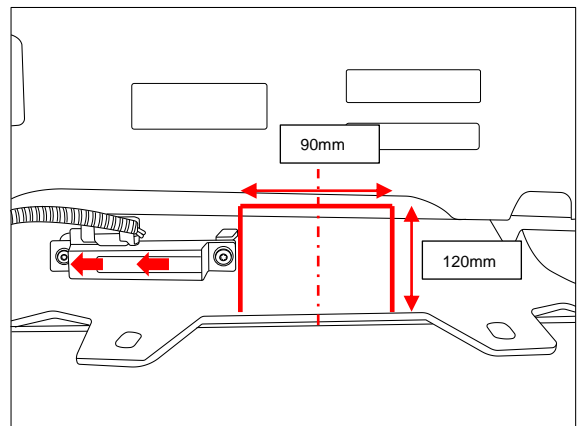

17. For the plug bracket.

Find an appropriate position on the bumper, mark out and drill 2 x \varnothing 5mm holes 69mm apart on bumper skin to support plug bracket. Refit bumper and other removed parts.

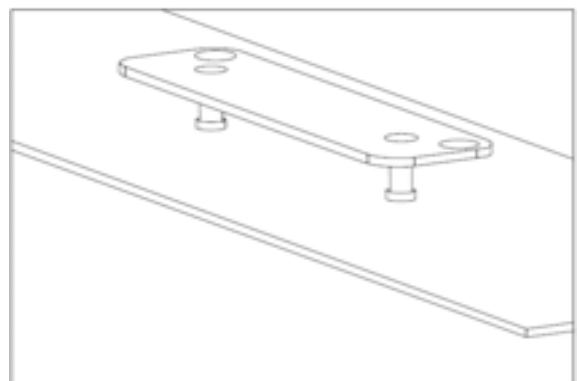

IMPORTANT

Due to possible vehicle variations, always confirm any noted vehicle colour wires with a multi-meter to ensure the correct function is identified before soldering or scotch locking. For vehicle wires denoted with two colours (example; RED/GREEN) the first colour will always be the main wire colour while the second colour is the thinner trace colour on the wire.

-
18. In the luggage compartment, remove the floor carpet.
 19. Remove the rear cargo blind.
 20. Fold down the rear seats.

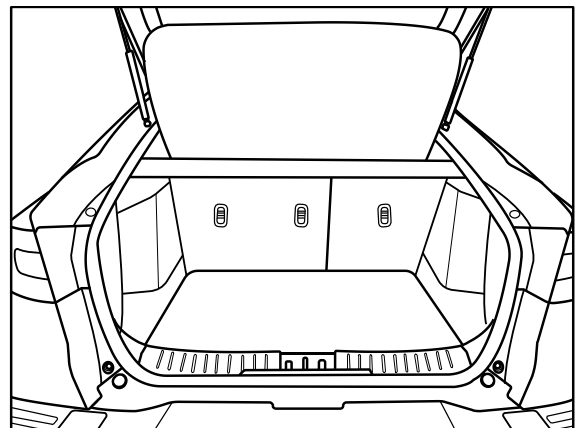

-
21. Remove the 2 trim clips (1) securing the rear scuff trim (2).
 22. Remove the rear scuff trim by lifting up.

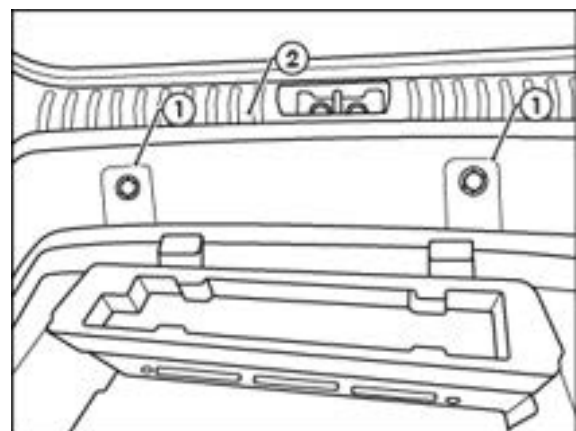

23. With Rear Bumper removed, connect the RHS Taillight connector (1) to the RHS Tail Lamp Patch.
24. Route the Trailer Wiring Harness (2) across the rear of the vehicle.
25. Connect the LHS Taillight connector (3) to the LHS Tail Lamp Patch.
26. Continue to route the Trailer Wiring Harness towards bottom LHS of Vehicle.

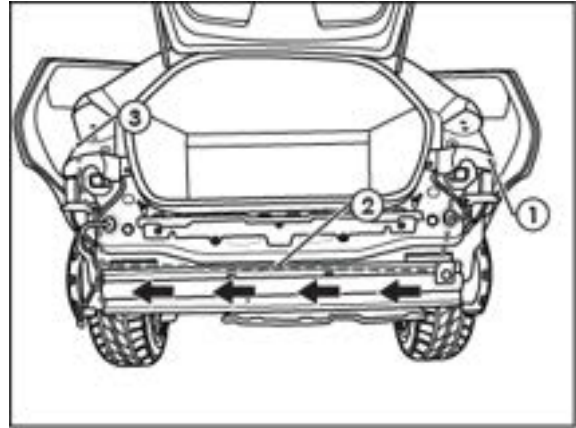

27. From underneath the LHS of the vehicle, dislodge the 40mm Blanking Grommet (1).
28. Feed the Trailer Wiring Harness through the 40mm hole and ensure that the 40mm Grommet is properly seated.

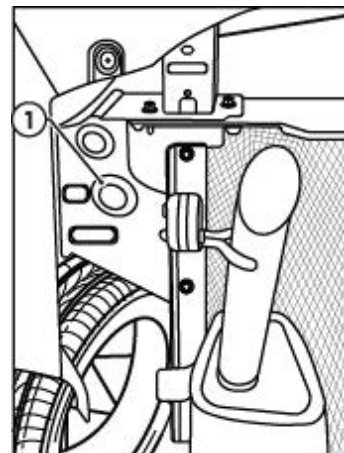

29. Using an alcohol wipe (not supplied), clean the LHS sheet metal area (1) as shown.
30. Connect the 12-way trailer patch connector (2) to the ECU (3) (P/No: 04826) and adhere the ECU to the cleaned surface on the sheet metal area (1).

Note: Ensure the ECU is mounted with the connector pointing downwards.

31. Secure the 6mm Ground Ring Terminal to the vehicle body earth point (4).

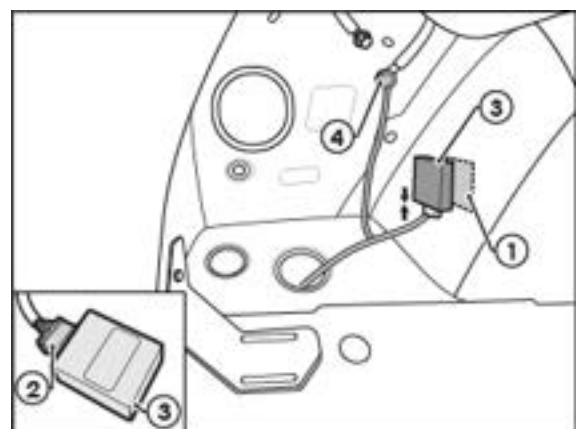

32. Locate the Black 16 Way Connector (1) on the LHS Interior of the vehicle.
33. Patch in the 16 Way connectors on the Trailer Wiring Harness in between the Vehicle 16 Way connectors.

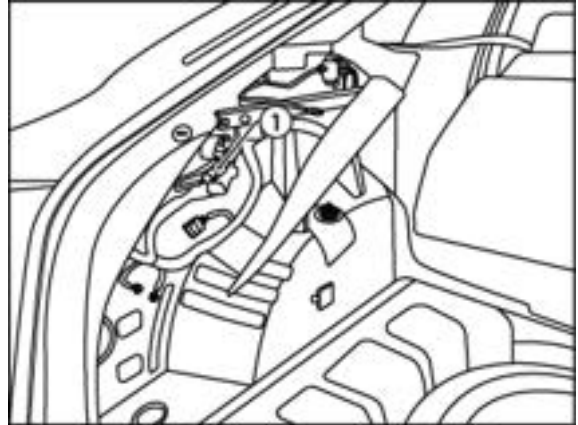

34. Route the orange power wire down the LHS towards the vehicle fuse panel behind the Passenger Glove compartment (1).
35. Open the Glove Compartment (1) and dislodge the Fuse Panel Cover (2).

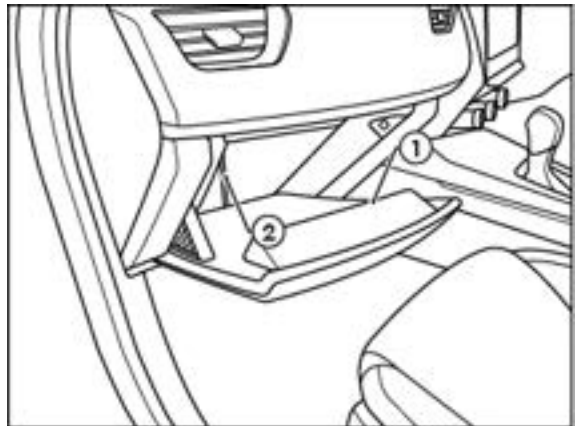

36. Insert the supplied 20 Amp Fuse (1) into the upper slot of the Add a Fuse harness (2).
37. Remove the 15 Amp Fuse (3) from the vehicle fuse panel and insert to the lower slot of the Add a Fuse harness (2).
38. Connect the Add a Fuse harness (2) into the slot where the 15 Amp Fuse was removed from the vehicle fuse panel.
39. Connect the trailer wire harness 1-way connector (4) to the Add a Fuse harness mating connector.

Note: To maintain correct electrical operation, ensure the fuse is inserted into the allocated slot in the orientation shown.

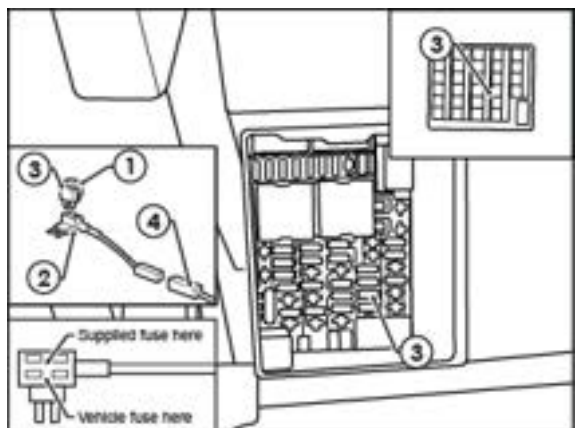

40. Connect the tail harness (tail length 400mm) 8-way connector (1) to the trailer patch mating 8-way connector (2).
41. Use silicone grease to seal the blue connectors
42. Secure all harness using supplied cable ties.
43. Test the trailer patch function using a light board or multi-meter.
44. Re-fit all removed parts (step 1-10, 20-26 in reverse) and secure all fasteners, ensuring there are no squeaks or rattles.
45. The RPA function can be disabled via Infotainment system.
46. Place the fitting instructions in the glove box after fitment.

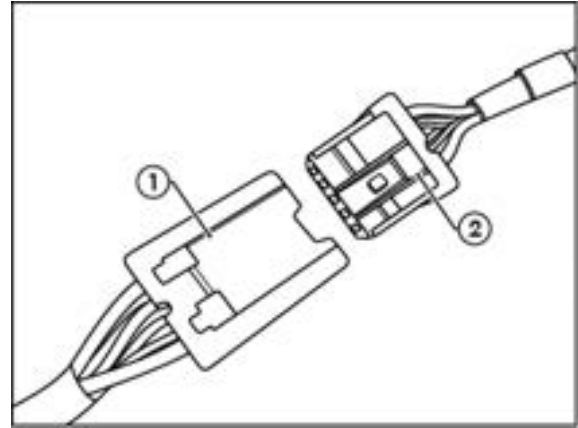



CUSTOMER INFORMATION

PLACE THESE INSTRUCTIONS IN THE VEHICLE'S GLOVEBOX AFTER INSTALLATION

THANK YOU FOR PURCHASING TRAILBOSS. WITH CORRECT MAINTENANCE AND CARE THIS PRODUCT WILL PROVIDE A LIFETIME OF TROUBLE-FREE OPERATION.

TOWBAR MAINTENANCE AND CARE:

1. Trailboss recommend that the towbar LUG or TBM (Trailer Ball Mount) Pull Pin and R-clip are removed and stored when not in use. Removal of LUG or TBM (Trailer Ball Mount) is advisable when not in use to assist with any of the following.
 - Ensure rear number plate is not obscured.
 - Allow maximum available departure angle and prevent any potential interference.
 - Prevent possible interference with vehicles reverse sensors or camera detecting a tow ball mount as an obstruction during reversing.
 - Removes towball mount as an obstruction for when moving around the rear of the vehicle.
2. Trailboss recommends routine inspection of your towbar to ensure trouble free towing.
 - Bolt security and tension should be regularly inspected and checked for correct tension. Replace any worn or defective parts with suitable grade & class fasteners. Inspection should be requested to coincide with vehicle major services.
3. It is the owner's responsibility to ensure towing and down ball weight capacities of the towing vehicle are not exceeded.
 - Towing and down ball weights allowable may differ according to model variations. Please refer to owner's manual or vehicle dealer to confirm exact rating for your vehicle model variant.
 - It is not uncommon for the vehicle tow rating to differ from the towbar rating. When this occurs, the lesser rating must be adhered to.
 - For vehicles fitted with enhanced vehicle functions that may be altered/changed when towing i.e Trailer sway mitigation, blind spot detection, adaptive cruise control etc. Please consult owner's manual to understand changes enabled when towing and after towing.

WARRANTY INFORMATION:

Trailboss Towbars are covered by a Lifetime Warranty.

Our goods come with guarantees that cannot be excluded under the Australian Consumer Law. You are entitled to a replacement or refund for a major failure and for compensation for any other reasonably foreseeable loss or damage. You are also entitled to have the goods repaired or replaced if the goods fail to be of acceptable quality and the failure does not amount to a major failure.

For further details please contact customer service on 1800 812 017.

PRO SERIES SILENT ANTI-RATTLE HITCH PIN

Your Trailboss towbar is equipped with a Pro Series Silent Anti-Rattle Hitch Pin technology to help reduce towbar tongue rattle in most driving conditions. Please ensure below instructions are understood and routine maintenance is carried out to ensure best towing experience.

Regularly inspect for wear and check the tightness of the Silent Anti-Rattle Hitch Pin. Follow instructions below to re-tighten the nut as necessary when movement and noise in the tow ball mount is noted.

- Before towing, ensure R-Clip is properly installed and hitch pin nut is installed and tensioned. Replacement parts are available from your Pro Series Distributor.

TOWBALL MOUNT REMOVAL/INSTALLATION

STEP 1

Insert Trailer Ball Mount (TBM) (a) into towbar hitchbox (b), aligning hole in TBM shank (c) with hole in hitchbox (d) (Fig. 1)

STEP 2

Insert Silent Anti-Rattle Hitch Pin (e) through hole in hitchbox and hole in TBM shank (g); ensure the locators are inserted into the notches in the hitchbox (Fig. 2)

STEP 3

Screw Silent Anti-Rattle Hitch Pin Nut (f) onto Smart Pin (g); tighten Smart Pin Nut until finger tight, ensuring TBM is restrained from up and down movement.

STEP 4

Tighten Silent Anti-Rattle Hitch Pin Nut by turning nut a further 1/8th of a turn in the clockwise direction using a 24mm spanner (Fig. 4).

STEP 5

Install Silent Anti-Rattle Hitch Pin R-Clip through the hole that provides best clearance or easiest access. (Fig. 5)

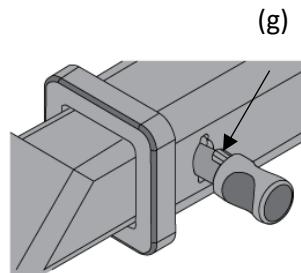
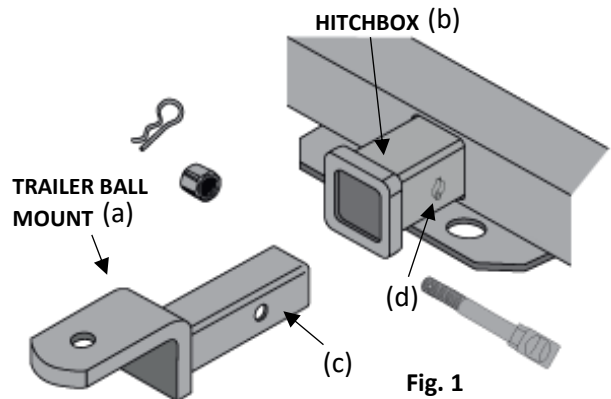

Fig. 2

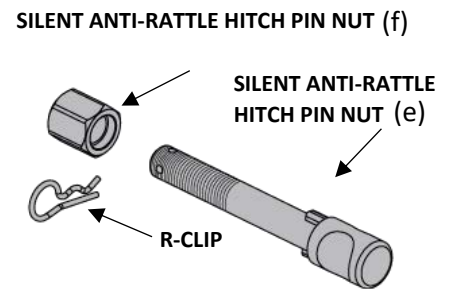

Fig. 3

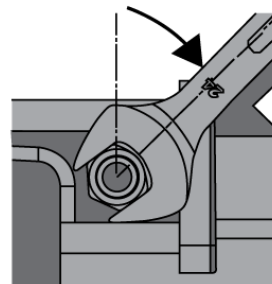

Fig. 4

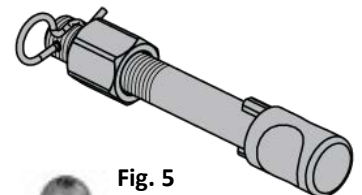

Fig. 5

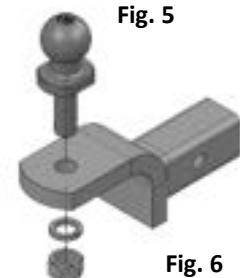

Fig. 6