

# TRAILBOSS

## Towbar Fitting Instructions

To Suit **RANGE ROVER EVOQUE SUV L538 SERIES 10/2011 ONWARDS**

Part Number **QTRV20L**

Rating **1800/180 kg**

PLACE THESE INSTRUCTIONS IN THE VEHICLE'S GLOVEBOX AFTER INSTALLATION IS COMPLETED

### **WARNING:**

1. Do not, drill, cut, weld or otherwise modify the tow bar.
2. If you are using electric welding on a motor vehicle, **always** check that the vehicle is not equipped with electronic engine or instrument management equipment. Failure to do so could **destroy** any onboard computers. If in doubt, check with the vehicle's manufacturer.
3. The high tensile fasteners supplied with this product were used to achieve the specified rating. If replacement is required ensure that fasteners of the same rating & quality are used. Contact an authorised **Trailboss** dealer if further information is required.
4. If TBM is used in inverted position tow ball may make contact with rear tailgate when lowered, which could cause damage.

### **General:**

1. Ensure all hardware items have been included refer to assembly diagram.
2. It is recommended that the instructions are read through and completely understood before making any attempt to fit this product.
3. Be wary of any changes to vehicle designs or other accessories that may conflict with the installation of this product.
4. Before drilling ensure that the area is clear of fuel, electrical & other components.
5. All holes drilled into the body panels shall have all burrs & swarf removed then coated with a suitable rust preventative paint.
6. For vehicles that require the bumper to be cut. Ensure cut out area is in correct position on the vehicle prior to cutting the bumper.
7. The high tensile fasteners supplied with this product were used to achieve the specified rating. If replacement is required ensure that fasteners of the same rating & quality are used. Contact an authorized **Trailboss** dealer if further information is required.
8. Ensure that all hardware is fastened to torque list below check fasteners on regular basis.
9. Tow bar load rating sticker provided with this product shall be conspicuously located on inside rear end of the driver's door. **(See diagram below).**
10. Trailboss recommends that you check your tow ball to ensure that it complies with the Australian standards **AS 4177.2.**
11. **PLEASE NOTE:** It is advised to remove your lug or tbn when not actually towing so as to produce a clear view of the vehicles registration plate if obscured, and to also provide maximum available departure angle
12. Pull Pin must be fit in down position.

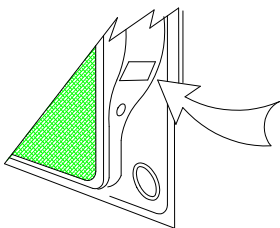

Place load rating sticker  
inside driver's door here

**FOR TRAILER TOWING PURPOSES ONLY**  
For towing capacity details please refer to vehicle owner's manual or to the manufacturer. Overloading can void your warranties.

#### **RECOMMENDED ASSEMBLY TORQUE LISTING**

<u>Diameter</u>	<u>Grade 8.8 Bolt</u>
M6	9.5 Nm
M8	21.7 Nm
M10	43.4 Nm
M12	77.3Nm
M14	146 Nm
M16	189.8 Nm

### **Tow bar Maintenance and Care.**

Trailboss recommends that bolt torque's, as listed below, are routinely and regularly inspected and checked for correct tension. Replace any worn or defective parts.

We recommended to remove Tow Ball Mounts (TBM's, tongues or lugs) when not being used for any considerable length of time.

So as to avoid injury, when not towing it is suggested that the tongue, Pull Pin and R-clip are removed then stored in a safe, clean and dry place, away from excessive moisture.

Hitch Pull Pins and spring "R" clips are regularly checked for proper installation. Replace any worn or defective parts.

# TRAILBOSS

## Towbar Fitting Instructions

To Suit **RANGE ROVER EVOQUE SUV L538 SERIES 10/2011 ONWARDS**

Part Number **QTRV20L**

Rating **1800/180 kg**

PLACE THESE INSTRUCTIONS IN THE VEHICLE'S GLOVEBOX AFTER INSTALLATION IS COMPLETED

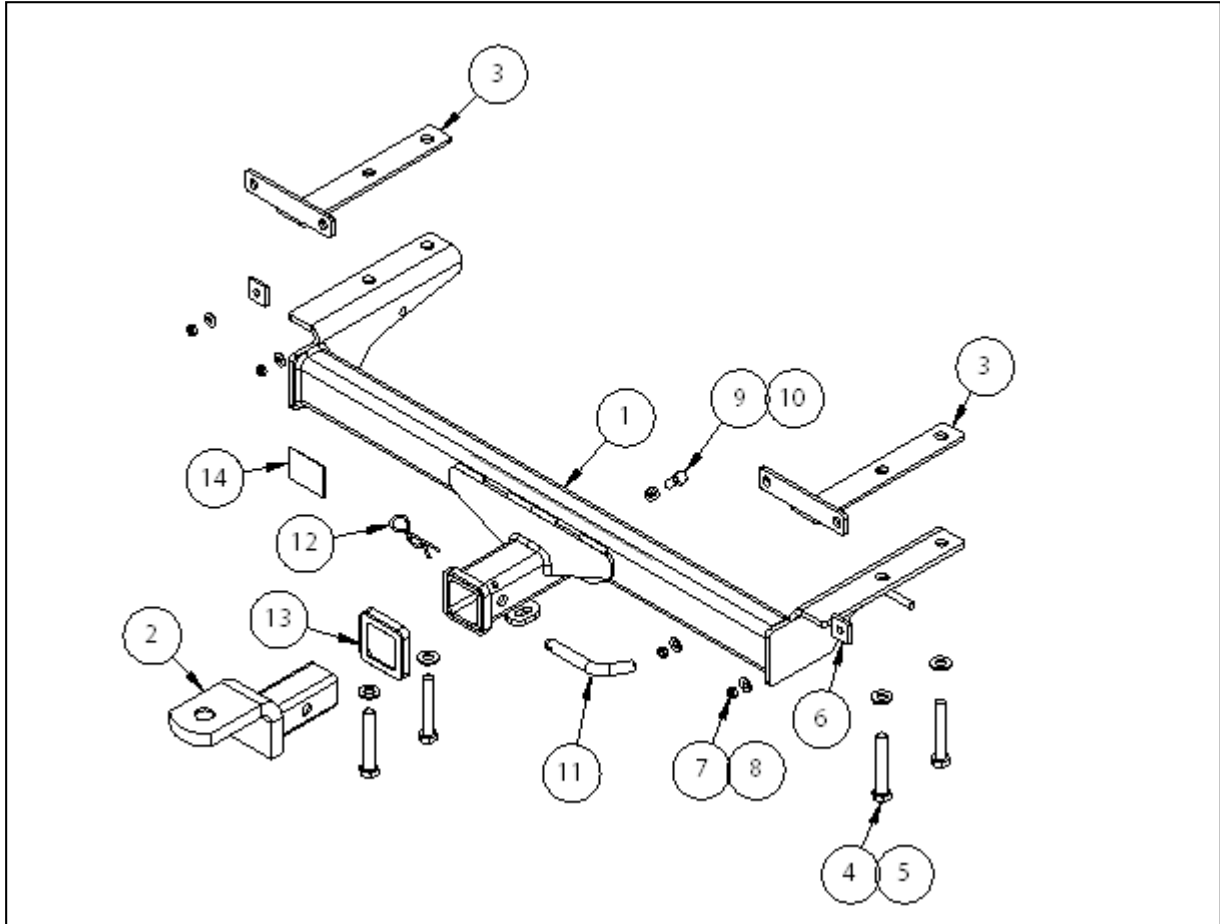

QTY	DESCRIPTION	ITEM NO
1	WELDED ASSY	1
1	TBM ASSEMBLY	2
2	REINF FACE PLATE	3
4	BOLT M14X90 8.8 ZP	4
4	FT WASHER M14X28X3 Z/P	5
2	LOOSE PLATE 32X32X6 11mm HOLE	6
4	NUT HEX M8-1.25 Z/P	7
4	WASHER FT M8X19.5X1.60 Z/P	8
1	SET SCREW HEX HD M10X30X1.5P	9
1	HEX NUT M10X1.5	10
1	PULL PIN	11
1	R CLIP	12
1	HITCH BOX COLLAR COVER	13
1	ACRYLIC COMPLIANCE PLATE	14

### ADDITIONAL ITEMS

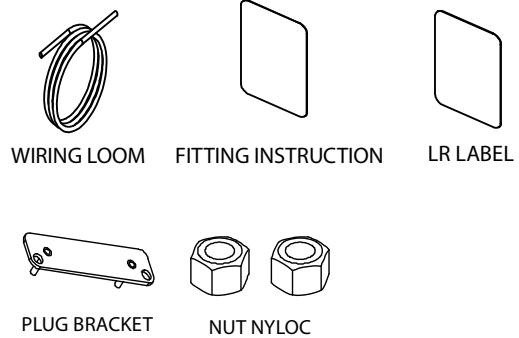



## Towbar Fitting Instructions

To Suit **RANGE ROVER EVOQUE SUV L538 SERIES 10/2011 ONWARDS**

Part Number **QTRV20L**

Rating **1800/180 kg**

PLACE THESE INSTRUCTIONS IN THE VEHICLE'S GLOVEBOX AFTER INSTALLATION IS COMPLETED

### INSTRUCTION:

#### REMOVAL OF BUMPER & IMPACT BEAM:

1. Disconnect reverse sensor plug connection.
2. Remove one 6mm Bolt, one plastic Scrivet and one self tapper screw from the inner Wheel arch. **(LH & RH side of vehicle).**
3. Release the rear muffler from the three Rubber hangers, and unhook the remaining Rubber Hanger from halfway up the exhaust. Support muffler if necessary.
4. Remove the four 6mm Bolts, holding the bottom of Bumper and Heat Shield, to rear panel.
5. Remove tail light plastic covers.  
**( LH & RH sides of vehicle )** to expose self tapered Screws.

Remove self tapered screws and release light assemblies from housing, disconnect plug connections and place light assemblies in a safe place.

6. Remove pop-out plastic Scrivet plugs; in rear Bottom corners of Tail gate cavity.  
**(LH & RH sides of vehicle.)**
7. Gently pull away side wheel arch flares.

Gently pull Bumper sides outwards from rear quarter panel. **(LH & RH sides of vehicle)**

Remove Bumper from vehicle, place on stand

8. Remove Exhaust hanging Bracket and discard.

Remove Bolts and Shipping Hook from Chassis and discard.

9. Remove the three Nuts **( LH & RH sides )** from Impact Beam, place impact to the side.

#### **DO NOT DISCARD IMPACT BEAM**

10. Raise and position Towbar over holes in chassis, clearing exhaust.

Insert M14 Bolt, Spring Washer and Flat Washer into forward most hole.

**(LH & RH sides of vehicle)**

Loosely tighten Bolts.

11. Fit loose bent Bracket over Impact beam lower studs, **(LH & RH sides of vehicle)** insert M14 Bolt, Spring Washer and Flat Washer into remaining Chassis Hole.

Loosely tighten M14 Bolts.

# TRAILBOSS

## Towbar Fitting Instructions

To Suit **RANGE ROVER EVOQUE SUV L538 SERIES 10/2011 ONWARDS**

Part Number **QTRV20L**

Rating **1800/180 kg**

PLACE THESE INSTRUCTIONS IN THE VEHICLE'S GLOVEBOX AFTER INSTALLATION IS COMPLETED

12. Refit Impact beam, with loose plate in-between rear panel and beam.  
**(on top stud of LH & RH sides of vehicle )**

Secure Impact beam, using M8 Flat Washer, Spring Washer and Nut on bottom studs. Use original locknuts on top studs.

Tighten all M14 Bolts and M8 Nuts to required torque specifications.

13. **HEAT SHIELD CUT-OUT.**

Remove Heat Shield from Bumper Bar. Cut out along the indentation, Cut out section same for **LH & RH side.**

14. Cut out centre section of heat shield 80mm wide x 125mm in height as shown in Figure 1.

15. **INNER SKIN BUMPER CUT OUT**

Cut out centre section of inner skin to 100mm wide x 135mm in height as shown in Figure 2.

**BE CAREFUL NOT TO CUT THROUGH OUTER SKIN OF BUMPER**

16. **OUTER SKIN BUMPER CUT OUT**

Cut out centre section of outer skin to 85mm wide x 125mm in height as shown in Figure 3.

17. Refit Heat Shield to inner Bumper.

18. Refit Bumper to Vehicle, in reverse steps of removal.

19. Raise muffler, re attach exhaust hanger rubbers.



**Figure 1**

## Towbar Fitting Instructions

To Suit **RANGE ROVER EVOQUE SUV L538 SERIES 10/2011 ONWARDS**

Part Number **QTRV20L**

Rating **1800/180 kg**

PLACE THESE INSTRUCTIONS IN THE VEHICLE'S GLOVEBOX AFTER INSTALLATION IS COMPLETED



**Figure 2**

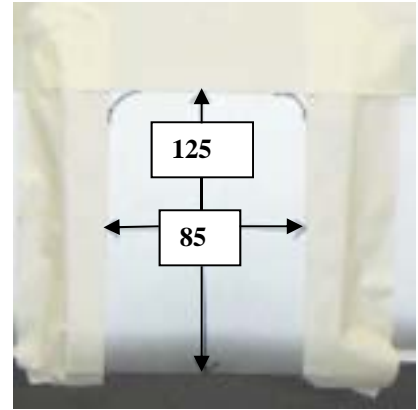

**Figure 3**



Wiring Loom Fitting Instructions  
To Suit Land Rover Evoque, Range Rover Sports  
Part Number 100765-WL

## Wiring Loom Installation Instructions

Land Rover Evoque (Page 2)

Range Rover Sports (Page 3)

Part No: 100765-WL

Land Rover Evoque -Tail Harness Length Require: 1200mm

Range Rover Sports -Tail Harness Length Require: 400mm

**RPA will disable when trailer connected**

**(applicable for non-LED trailers only).**

# TRAILBOSS

## Wiring Loom Fitting Instructions To Suit Land Rover Evoque, Range Rover Sports Part Number 100765-WL

### Land Rover Evoque (go to page 3 for Range Rover Sports).

1. On the LHS rear of the vehicle, locate the 4-way and the 8-way break out connectors.
2. Disconnect the 4-way and the 8-way blanking plug connector and connect the trailer patch connector (100765-WL) in between.
3. Insert terminals into the 8-way and 4-way blanking connector in the following configuration (refer to connectors for pin locations):

8-way connector			
PIN	COLOUR	PIN	COLOUR
1	-	6	BLACK
2	BROWN	7	RED
3	-	8	-
4	YELLOW		
5	GREEN		

4-way connector	
PIN	COLOUR
1	-
2	WHITE
3	-
4	-

4. Connect the trailer patch harness to the tail harness (tail length 1200mm).
5. Using electrical grease or silicone, water proof the back of the tail harness and trailer patch harness connectors.
6. Mount the tail harness socket to the tow bar mounting bracket using M4 fasteners (not supplied).
7. Secure the tail harness to the tow bar using cable ties (not supplied).
8. Test the Trailer Harness function using a Light Board or multimeter.
9. Secure all Harnesses using cables ties (not supplied).
10. Re-fit all removed parts and secure all fasteners, ensuring there are no squeaks or rattles.
11. Place instructions in glove box after fitment.



Wiring Loom Fitting Instructions  
To Suit Land Rover Evoque, Range Rover Sports  
Part Number 100765-WL

**Range Rover Sports (go to page 2 for Land Rover Evoque).**

1. On the centre rear of the vehicle, locate the 4-way and the 6-way break out connectors from underneath the bumper cavity.
2. Disconnect the 4-way and the 6-way blanking plug connector.
3. Insert terminals into the 6-way and 4-way blanking connector in the following configuration (refer to connectors for pin locations):

**6-way connector**

PIN	COLOUR
1	YELLOW
2	-
3	GREEN
4	RED
5	BLACK
6	BROWN

**4-way connector**

PIN	COLOUR
1	-
2	-
3	WHITE
4	-

4. Connect the trailer patch harness to the tail harness (tail length 400mm).
5. Using electrical grease or silicone, water proof the back of the tail harness and trailer patch harness connectors.
6. Mount the tail harness socket to the tow bar mounting bracket using M4 fasteners (not supplied).
7. Secure the tail harness to the tow bar using cable ties (not supplied).
8. Test the Trailer Harness function using a Light Board or multimeter.
9. Secure all Harnesses using cables ties (not supplied).
10. Re-fit all removed parts and secure all fasteners, ensuring there are no squeaks or rattles.
11. Place instructions in glove box after fitment.





# FITTING INSTRUCTIONS

## Silent Anti-Rattle Hitch Pin (PR0001)

• These fitting instructions are supplied to ensure understanding of how the HITCH PIN should be fitted and used correctly.

• Once installed, we recommend **ALL** instructions are kept and placed in the vehicle glove box.

**NOTE: Routine maintenance and inspection of the towbar & HITCH PIN is required. Regularly inspect for wear and check the tightness of the Hitch Pin. Follow instructions below to retighten the nut when necessary.**

**\*Do not tow with your vehicle if the R CLIP or the HITCH PIN is loose or missing. Replacement parts are available from your Pro Series Distributor.**

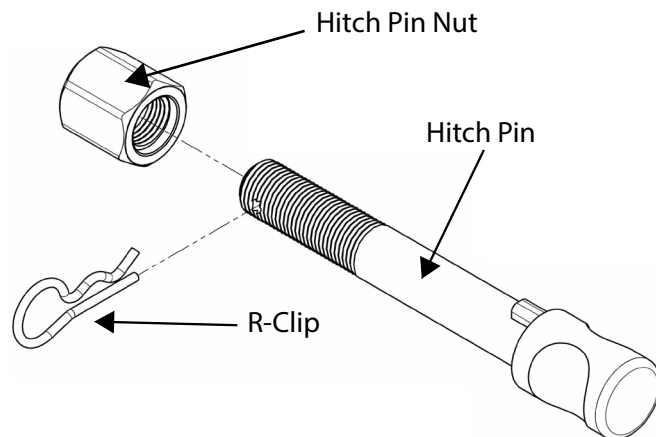

Fig 1. Silent Anti-Rattle Hitch Pin assembly

### STEP 1

Insert Trailer Ball Mount (TBM) into towbar HITCHBOX, aligning hole in TBM SHANK with hole in HITCHBOX (Fig 2).

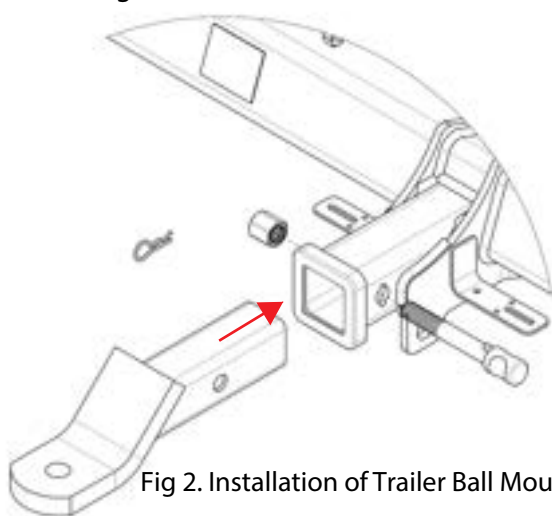

Fig 2. Installation of Trailer Ball Mount

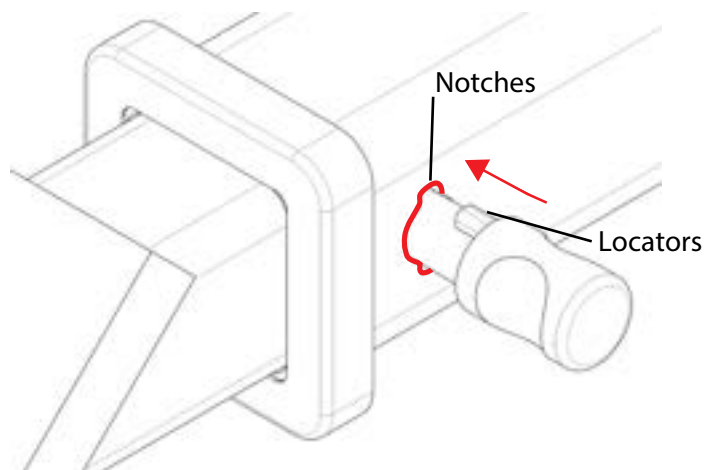

Fig 3. Silent Anti-Rattle Hitch Pin orientation

### STEP 2

Insert HITCH PIN through hole in HITCHBOX and hole in TBM SHANK; ensure the LOCATORS are inserted into the NOTCHES in the HITCHBOX (Fig. 3).

### STEP 3

Screw HITCH PIN NUT onto HITCH PIN ; tighten HITCH PIN NUT until finger tight, ensuring TBM is restrained from movement.

### STEP 4

Tighten HITCH PIN NUT by turning nut a further 1/8th of a turn in the clockwise direction using a 24mm spanner (Fig. 4).

### STEP 5

Install HITCH PIN R CLIP through the hole on the HITCH PIN (Fig. 1).

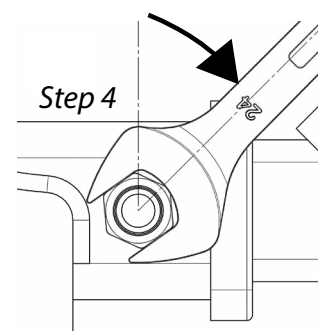

Fig 4. Tightening of Silent Anti-Rattle Hitch Pin Nut