



Towbar Fitting Instructions
To Suit **LAND ROVER DISCOVERY SPORT L550 7SEAT CL4**
Part Number **QTRV24L**
Rating **2200/150 kg**

PLACE THESE INSTRUCTIONS IN THE VEHICLE'S GLOVEBOX AFTER INSTALLATION IS COMPLETED

WARNING:

1. Do not, drill, cut, weld or otherwise modify the tow bar.
2. If you are using electric welding on a motor vehicle, **always** check that the vehicle is not equipped with electronic engine or instrument management equipment. Failure to do so could **destroy** any onboard computers. If in doubt, check with the vehicle's manufacturer.
3. The high tensile fasteners supplied with this product were used to achieve the specified rating. If replacement is required ensure that fasteners of the same rating & quality are used. Contact an authorised **Trailboss** dealer if further information is required.
4. If TBM is used in inverted position tow ball may make contact with rear tailgate when lowered, which could cause damage.

General:

1. Ensure all hardware items have been included refer to assembly diagram.
2. It is recommended that the instructions are read through and completely understood before making any attempt to fit this product.
3. Be wary of any changes to vehicle designs or other accessories that may conflict with the installation of this product.
4. Before drilling ensure that the area is clear of fuel, electrical & other components.
5. All holes drilled into the body panels shall have all burrs & swarf removed then coated with a suitable rust preventative paint.
6. For vehicles that require the bumper to be cut. Ensure cut out area is in correct position on the vehicle prior to cutting the bumper.
7. The high tensile fasteners supplied with this product were used to achieve the specified rating. If replacement is required ensure that fasteners of the same rating & quality are used. Contact an authorized **Trailboss** dealer if further information is required.
8. Ensure that all hardware is fastened to torque list below check fasteners on regular basis.
9. Tow bar load rating sticker provided with this product shall be conspicuously located on inside rear end of the driver's door. **(See diagram below).**
10. Trailboss recommends that you check your tow ball to ensure that it complies with the Australian standards **AS 4177.2.**
11. **PLEASE NOTE:** It is advised to remove your LUG or TBM when not actually towing so as to produce a clear view of the vehicles registration plate if obscured, and to also provide maximum available departure angle

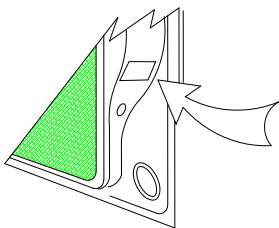

Place load rating sticker
inside driver's door here

FOR TRAILER TOWING PURPOSES ONLY
For towing capacity details please refer to vehicle owner's manual or to the manufacturer. Overloading can void your warranties.

RECOMMENDED ASSEMBLY TORQUE LISTING

Diameter	Grade 8.8 Bolt
M6	9.5 Nm
M8	21.7 Nm
M10	43.4 Nm
M12	77.3Nm
M14	146 Nm
M16	189.8 Nm

Tow bar Maintenance and Care.

Trailboss recommends that bolt torque's, as listed below, are routinely and regularly inspected and checked for correct tension. Replace any worn or defective parts.

We recommended to remove Tow Ball Mounts (TBM's, tongues or lugs) when not being used for any considerable length of time.

So as to avoid injury, when not towing it is suggested that the tongue, Pull Pin and R-clip are removed then stored in a safe, clean and dry place, away from excessive moisture.

Hitch Pull Pins and spring "R" clips are regularly checked for proper installation. Replace any worn or defective parts.

Cequent Customer Service
Ph: 1800 812 017 Fax: 03 9898 3299
Email: info@cequent.com.au
Post: PO Box 4050, Dandenong South VIC 3175

TRAILBOSS

Towbar Fitting Instructions
 To Suit **LAND ROVER DISCOVERY SPORT L550 7SEAT CL4**
 Part Number **QTRV24L**
 Rating **2200/150 kg**

PLACE THESE INSTRUCTIONS IN THE VEHICLE'S GLOVEBOX AFTER INSTALLATION IS COMPLETED

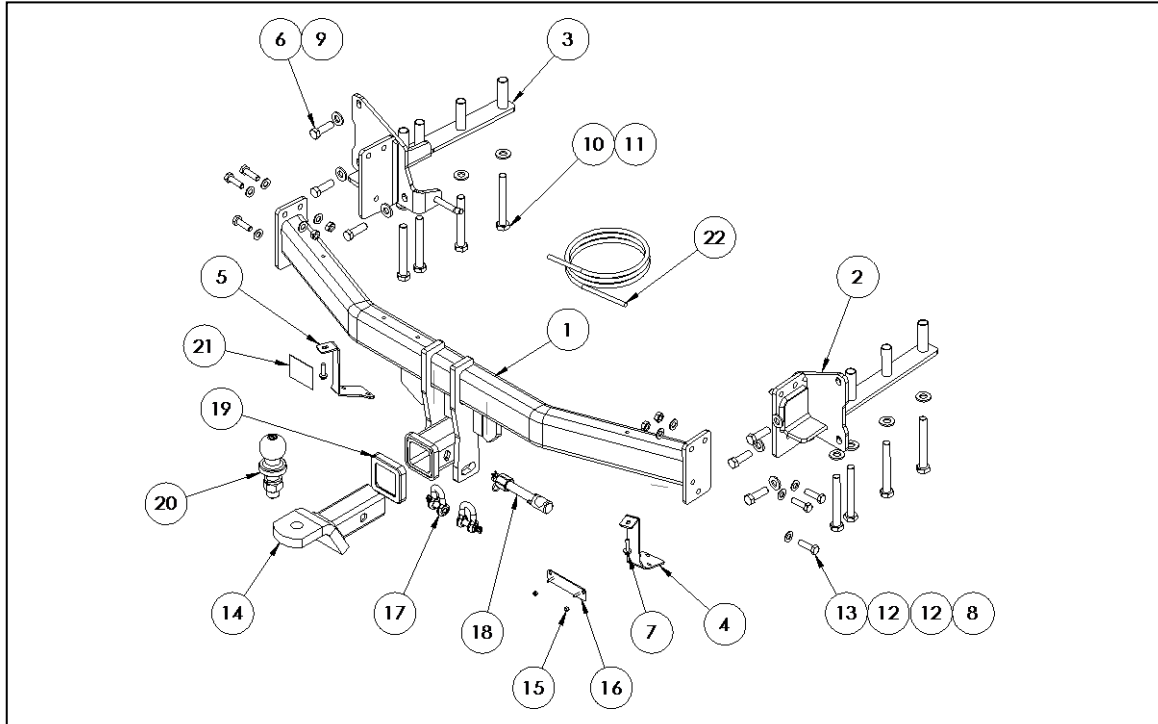

ITEM NO	DESCRIPTION	QTY.
1	LANDROVER DISCOVERY WELDED ASSEMBLY	1
2	SIDE ARM RHS	1
3	SIDE ARM LHS	1
4	RHS BUMPER TAB	1
5	LHS BUMPER TAB	1
6	WASHER PLAIN 1/2X1-1/8X16G	6
7	TEK SCREW 14-20 HEX HD 22MM	2
8	NUT HEX HD M10 X 1.25P G8	6
9	SET SCREW M12X40X1.75P G8.8	6
10	BOLT HEX HD M14 X 110 X 2.0P G8.8	8
11	WASHER PLAIN M14 X 28 X 3	8
12	WASHER PLAIN M10 X 21 X 1.6	12
13	SETSCREW HXHD M10X35X1.25 G8.8	6
14	TBM	1
15	NUT NYLON LOCK HEX HD M4X0.7P G8	2
16	VE PLUG BRACKET	1
17	D SHACKLE E7 PIN 10MM WLL 1.0T G-S	2
18	SILENT HITCH PIN CLASS 4 ASSEMBLY SILVER	1
19	HITCH BOX COLLAR COVER	1
20	TOWBALL 50MM CHROME 3500KG PRO	1
21	ACRYLIC CP STICKER	1
22	WIRING LOOM	1

Cequent Customer Service
 Ph: 1800 812 017 Fax: 03 9898 3299
 Email: info@cequent.com.au
 Post: PO Box 4050, Dandenong South VIC 3175

Towbar Fitting Instructions

To Suit **LAND ROVER DISCOVERY SPORT L550 7SEAT CL4**

Part Number **QTRV24L**

Rating **2200/150 kg**

PLACE THESE INSTRUCTIONS IN THE VEHICLE'S GLOVEBOX AFTER INSTALLATION IS COMPLETED

1. Remove 2 x torx head screws from underside of bumper securing centre plastic trim. Carefully unclip centre trim and set aside for later.



2. Remove 4 x hex head screws securing bumper to impact beam.



3. Remove 2 x phillips head screws and 1 x torx head screw from inside wheel arch.

Repeat for opposite side.



Cequent Customer Service

Ph: 1800 812 017 Fax: 03 9898 3299

Email: info@cequent.com.au

Post: PO Box 4050, Dandenong South VIC 3175

Towbar Fitting Instructions

To Suit **LAND ROVER DISCOVERY SPORT L550 7SEAT CL4**

Part Number **QTRV24L**

Rating **2200/150 kg**

PLACE THESE INSTRUCTIONS IN THE VEHICLE'S GLOVEBOX AFTER INSTALLATION IS COMPLETED

4. Carefully peel back wheel arch trim to expose corners of bumper.

Remove 1 x hex head screw from corner of bumper.

Repeat for opposite side.



5. Inside boot cavity, remove corner lining behind LHS taillight via 1 x flat head screw.



6. Also in boot cavity, on right side of vehicle, pop out plastic vent to expose headlight screw.



Cequent Customer Service

Ph: 1800 812 017 Fax: 03 9898 3299

Email: info@cequent.com.au

Post: PO Box 4050, Dandenong South VIC 3175

Towbar Fitting Instructions

To Suit **LAND ROVER DISCOVERY SPORT L550 7SEAT CL4**

Part Number **QTRV24L**

Rating **2200/150 kg**

PLACE THESE INSTRUCTIONS IN THE VEHICLE'S GLOVEBOX AFTER INSTALLATION IS COMPLETED

7. Remove 1 x plastic flat head spring screw from behind removed plastic vent. Carefully remove taillights by pulling rearward, unclipping any attached wiring.

Repeat for opposite side (Note: Screw located behind lining removed in Step 5).



8. Remove 1 x Phillips head screw from bumper now exposed by removal of taillight.

Repeat for opposite side.



9. Carefully unclip bumper from corners ensuring to disconnect any wiring that may be connected. Carefully set aside.

Cequent Customer Service
Ph: 1800 812 017 Fax: 03 9898 3299
Email: info@cequent.com.au
Post: PO Box 4050, Dandenong South VIC 3175

Towbar Fitting Instructions

To Suit **LAND ROVER DISCOVERY SPORT L550 7SEAT CL4**

Part Number **QTRV24L**

Rating **2200/150 kg**

PLACE THESE INSTRUCTIONS IN THE VEHICLE'S GLOVEBOX AFTER INSTALLATION IS COMPLETED

10. Remove rubber mount from exhaust hanger mounted to the impact beam.

Repeat for opposite side.



11. Unclip sensors connected to impact beam. Remove impact beam via 6 x hex head bolts.



12. Lower spare tyre underneath vehicle via winch located inside boot, below floor covering.

Towbar Fitting Instructions

To Suit **LAND ROVER DISCOVERY SPORT L550 7SEAT CL4**

Part Number **QTRV24L**

Rating **2200/150 kg**

PLACE THESE INSTRUCTIONS IN THE VEHICLE'S GLOVEBOX AFTER INSTALLATION IS COMPLETED

13. Remove 2 x rubber mounts from exhaust hangers located behind exhaust head.

Repeat for opposite side.

Carefully lower exhaust ensuring that it is adequately supported. If further lowering is required, remove exhaust mount located underneath the vehicle near its centre.



14. Remove 1 x heat shield each side located underneath chassis rail via 6 x hex head nuts.



15. Remove factory tow hook on RHS of vehicle by removing 2 x hex head bolts from underside of chassis rail.



Cequent Customer Service

Ph: 1800 812 017 Fax: 03 9898 3299

Email: info@cequent.com.au

Post: PO Box 4050, Dandenong South VIC 3175

TRAILBOSS

Towbar Fitting Instructions

To Suit **LAND ROVER DISCOVERY SPORT L550 7SEAT CL4**

Part Number **QTRV24L**

Rating **2200/150 kg**

PLACE THESE INSTRUCTIONS IN THE VEHICLE'S GLOVEBOX AFTER INSTALLATION IS COMPLETED

16. Insert side arms into chassis rail and loosely secure with 4 x M14 bolts on underside of chassis rail complete with 1 x M14 washer per bolt.



17. Loosely secure side arms to rear panel via 3 x M12 x 40 bolts complete with 1 x M12 washer per bolt.

Repeat for opposite side.



18. Loosely secure bumper tabs to rear of cross tube via 1 x tek screw per side.

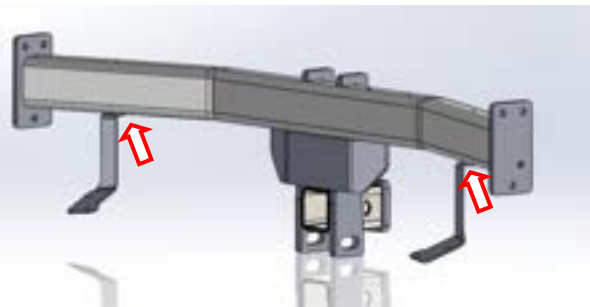

Cequent Customer Service

Ph: 1800 812 017 Fax: 03 9898 3299

Email: info@cequent.com.au

Post: PO Box 4050, Dandenong South VIC 3175

Towbar Fitting Instructions

To Suit **LAND ROVER DISCOVERY SPORT L550 7SEAT CL4**

Part Number **QTRV24L**

Rating **2200/150 kg**

PLACE THESE INSTRUCTIONS IN THE VEHICLE'S GLOVEBOX AFTER INSTALLATION IS COMPLETED

19. Loosely secure welded centre section to side arms via 6 x M10 bolts complete with 2 x M10 washers and 1 x M10 nut per bolt.

Tighten all fasteners to the torques listed below:

M14- 124 N.m

M12- 77 N.m

M10- 48 N.m



20. Remove sensor on front of impact beam and fit to top left holes on cross beam using factory scrivenets.



21. On the centre of the plastic trim removed in Step 1, identify the centre line and mark out a 130mm tall x 95mm wide rectangle, starting from the bottom edge of the trim, as measured following the inside edge.

Before cutting the plastic trim, use an appropriate metal cutting tool to remove segment of metal support found on the inside face of plastic trim. Once this has been cut, use appropriate tool to cut out rectangle on plastic trim.

Once metal support and plastic trim have been cut, reattach trim to bumper and use as a stencil to mark out uncut area on bumper. Remove trim and cut marked area on bumper.

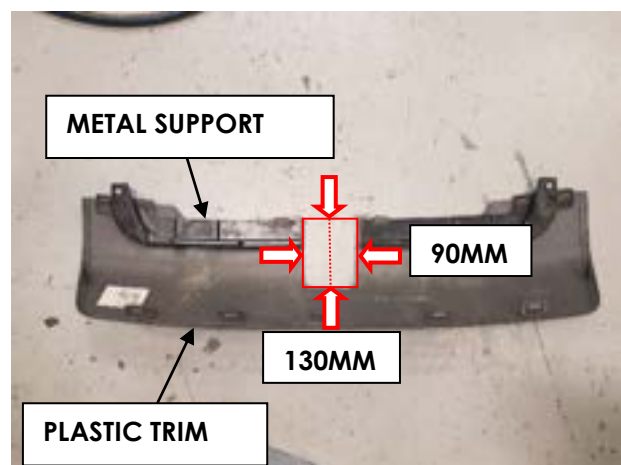

Cequent Customer Service

Ph: 1800 812 017 Fax: 03 9898 3299

Email: info@cequent.com.au

Post: PO Box 4050, Dandenong South VIC 3175



Towbar Fitting Instructions

To Suit **LAND ROVER DISCOVERY SPORT L550 7SEAT CL4**

Part Number **QTRV24L**

Rating **2200/150 kg**

PLACE THESE INSTRUCTIONS IN THE VEHICLE'S GLOVEBOX AFTER INSTALLATION IS COMPLETED

22. Reassemble vehicle following steps 1-14 in reverse. Connect exhaust rubber mounts to exhaust hangers located on towbar side arms.

Once bumper has been reinstalled, align holes below bumper with bumper tabs on towbar. Once aligned tighten tek screw and replace scrivenets.

23. Mark out and drill 2 x Ø5mm holes 69mm apart on bumper skin to support plug bracket. Feed bracket through drilled holes prior to reinstalling bumper.

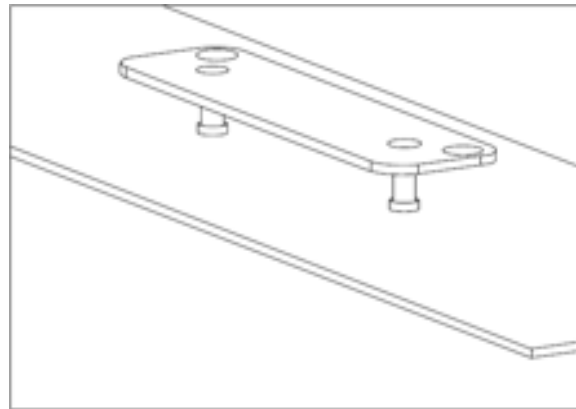

Cequent Customer Service

Ph: 1800 812 017 Fax: 03 9898 3299

Email: info@cequent.com.au

Post: PO Box 4050, Dandenong South VIC 3175



Wiring Loom Fitting Instructions
To Suit Land Rover Discovery Sport 550 Series
Part Number 101409-WL

Wiring Loom Installation Instructions

**Land Rover Discovery Sport 550 Series
Part No: 101409-WL**

Tail Harness Length Required: 1200mm

Wiring Loom Installation Time: Approx. 25 Mins

TRAILBOSS

Wiring Loom Fitting Instructions To Suit Land Rover Discovery Sport 550 Series Part Number 101409-WL

1. Gain access to the rear of the vehicle, remove the luggage compartment floor trim.
2. Remove the luggage compartment rear trim.
3. Remove the LHS and RHS tool trays.
4. On the LHS of the spare wheel well, locate and remove the vehicle grommet (1).
5. Cut a Ø30mm hole into the center of the grommet. Refit grommet after cutting.
6. Connect the trailer patch (P/No: 101409-WL) 13-way connector to the vehicle breakout connector (2).



7. At the rear exterior of the vehicle, mount the tail harness socket to the tow bar mounting bracket using M4 fasteners (not supplied).
8. Route the tail harness (tail length: 1200mm) across the LHS and up into the previously cut out grommet. Adjust the trailer patch harness grommet so that it is seated correctly and cable tie (not supplied) in place.
9. Seal the cut out grommet with silicone (not supplied) after routing.
10. Connect the tail harness (tail length 1200mm) 8-way connector to the trailer patch mating 8-way connector.
11. Refit the tail lights.
12. Test the trailer patch function using a light board or multi-meter.
13. Secure all harnesses using cable ties (not supplied).
14. Re-fit all removed parts and secure all fasteners, ensuring there are no squeaks or rattles.
15. Place the fitting instructions in the glove box after fitment.
16. The park assist can be disabled via a switch on the dash next to the entertainment screen.



FITTING INSTRUCTIONS

Silent Anti-Rattle Hitch Pin (PR0001)

• These fitting instructions are supplied to ensure understanding of how the HITCH PIN should be fitted and used correctly.

• Once installed, we recommend **ALL** instructions are kept and placed in the vehicle glove box.

NOTE: Routine maintenance and inspection of the towbar & HITCH PIN is required. Regularly inspect for wear and check the tightness of the Hitch Pin. Follow instructions below to retighten the nut when necessary.

***Do not tow with your vehicle if the R CLIP or the HITCH PIN is loose or missing. Replacement parts are available from your Pro Series Distributor.**

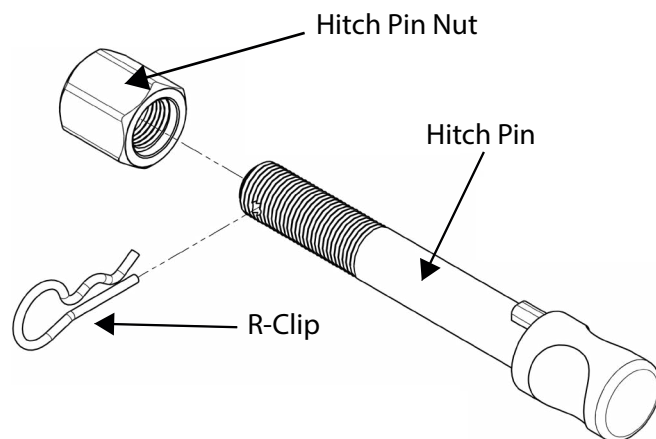

Fig 1. Silent Anti-Rattle Hitch Pin assembly

STEP 1

Insert Trailer Ball Mount (TBM) into towbar HITCHBOX, aligning hole in TBM SHANK with hole in HITCHBOX (Fig 2).

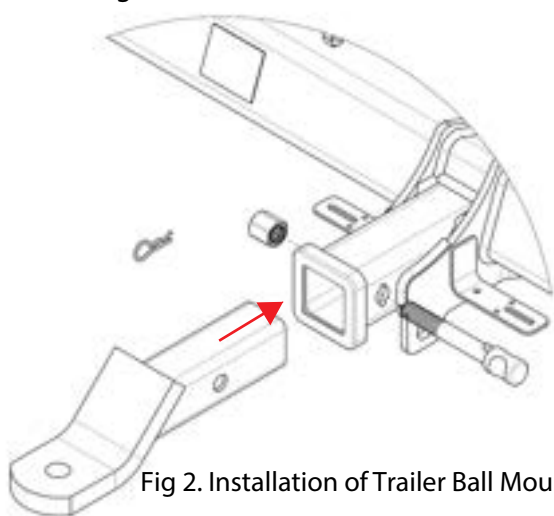

Fig 2. Installation of Trailer Ball Mount

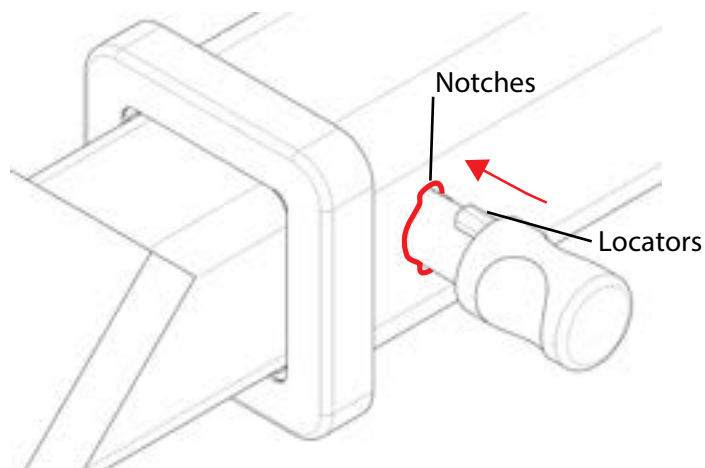

Fig 3. Silent Anti-Rattle Hitch Pin orientation

STEP 2

Insert HITCH PIN through hole in HITCHBOX and hole in TBM SHANK; ensure the LOCATORS are inserted into the NOTCHES in the HITCHBOX (Fig. 3).

STEP 3

Screw HITCH PIN NUT onto HITCH PIN ; tighten HITCH PIN NUT until finger tight, ensuring TBM is restrained from movement.

STEP 4

Tighten HITCH PIN NUT by turning nut a further 1/8th of a turn in the clockwise direction using a 24mm spanner (Fig. 4).

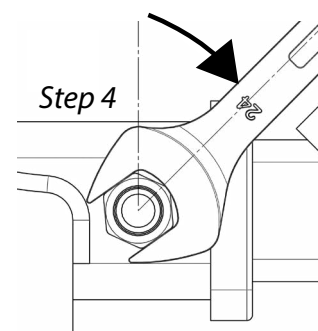

Fig 4. Tightening of Silent Anti-Rattle Hitch Pin Nut

STEP 5

Install HITCH PIN R CLIP through the hole on the HITCH PIN (Fig. 1).