

PRODUCT DETAILS:

Part Number:	QTRV28L	Maximum Towing Braked:	2200	kg
ECU Number:	WLE70010	Maximum Towing Unbraked:	750	kg
Tail Harness Length Required:	1200 mm	Maximum Static Ball Load:	150	kg
TBM/Lug Part Number:	21201			

FITTING DETAILS:

Towbar Installation Time:	80 Mins.	RPA Disable/Other:	YES
Total Installation Time:	110 Mins.		
Bumper Cut Required:	Yes		

Note:

- RPA Disable via infotainment.
- Prewire fuse location F12 20A.

TRAILBOSS RECOMMENDS THAT INSTRUCTIONS ARE READ AND UNDERSTOOD COMPLETELY PRIOR TO FITMENT.

BEFORE YOU START:

Check all hardware items have been included refer to assembly diagram.
Please ensure this towbar is only fitted to vehicle models as per Trailboss application guide.

Bumper Cuts

Vehicle and bumper variations can and do occur during vehicle manufacture after initial towbar design. Fitment of towbar to vehicle and accuracy of bumper cut must be assessed prior to any bumper modifications made. Incorrect bumper cuts are not covered under Trailboss warranty.

NOTE: Bumper cuts need to be approached with care, refer to notes below.

- Bumper centreline – where the centreline of the bumper needs to be determined, the installer must assess centre point by measurement of bumper width or determining two symmetrical reference points to give centreline.
- Bumper edge – To assist with accurate bumper cut measurement, reference to the start of the bumper edge is now being commonly used.
 - Measure from bottom edge along bumper and around corner to the 70 mm point (Figure 1).
 - Do not measure from visible bumper front of corner, upwards (Figure 2).

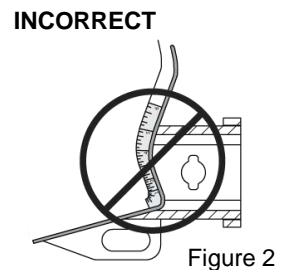
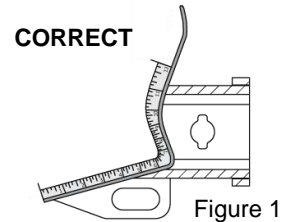

Drilling

- For any required drilling during installation, ensure that the area is clear of fuel, electrical & other components that may be damaged.
- All holes drilled into metal body panels shall have all burrs & swarf removed then coated with a suitable rust preventative paint.

Bolts/Fasteners

- Ensure that all hardware is fastened to correct torque as specified in this fitting instruction.
- All fasteners supplied with this product are used to achieve a specified clamp loading. If replacement is required ensure that fasteners of the same grade and class are used.

NOTE: Achieving correct torque is critical to proper installation and responsibility of the installer. Towbar failures attributed to tension issues from over tightening or under tightening are not covered by Trailboss warranty.

Product Labels

- a. Towbar load rating sticker provided with this product shall be conspicuously located on inside rear end of the driver's door.

WARNING:

Do not, drill, cut, weld or otherwise modify the towbar.

FOR TOWING PURPOSES ONLY - This towbar is designed and tested by Trailboss to adhere to ADR 62/02 which provides only for the expected load demands of towing.

i TOWBAR ASSEMBLY DIAGRAM

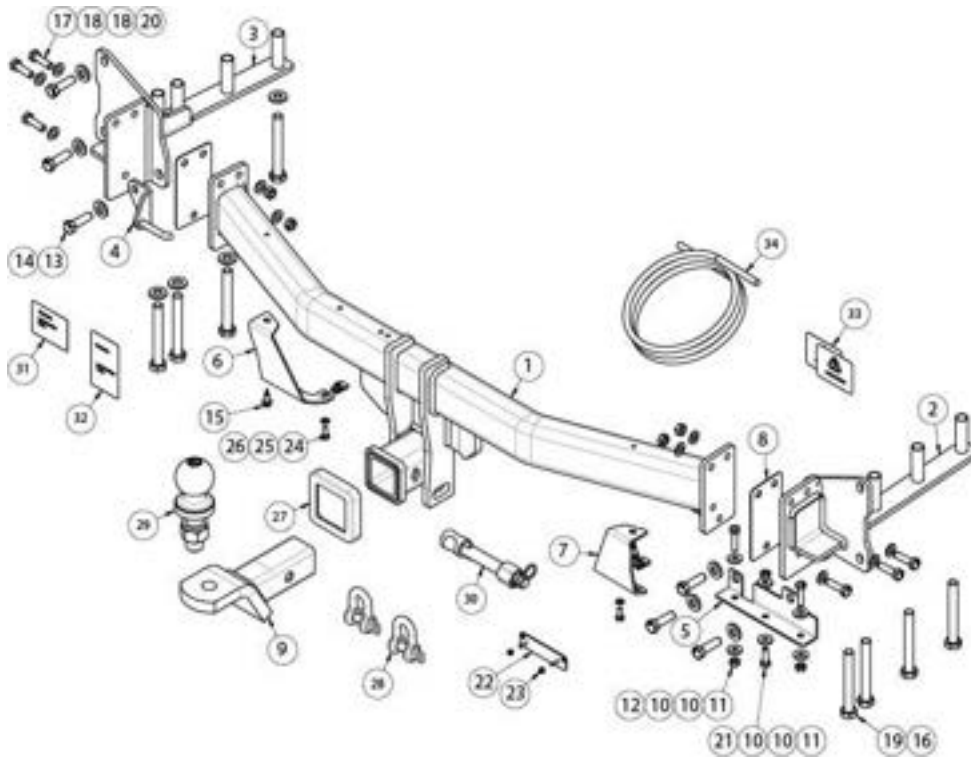

ITEM	DESCRIPTION	QTY
1	LAND ROVER DISCOVERY SPORT	1
2	SIDE ARM RHS	1
3	SIDE ARM LHS	1
4	EXHAUST HANGER BRACKET, LH	1
5	AD BLUE BRACKET	1
6	BUMPER BRACKET, LH	1
7	BUMPER BRACKET, RH	1
8	END PLATE SPACER	2
9	TRAILER BALL MOUNT	1
10	WASHER PLAIN M8x22x3	6
11	NUT HEX HD M8x1.25P	3
12	BOLT HEX HD M8x35x1.25P	2
13	WASHER PLAIN 1/2"	6
14	SET SCREW HEX HD M12x40x1.75P	6
15	TEK SCREW 14-20 HEX HD 22mm	2
16	WASHER PLAIN M14x28x3	8
17	SET SCREW HEX HD M10x35x1.25P	6

ITEM	DESCRIPTION	QTY
18	WASHER PLAIN M10x21x1.6	12
19	BOLT HEX HD M14x110x2.0P	8
20	NUT HEX HD M10x1.25P	6
21	SET SCREW HEX HD M8x25x1.25P	1
22	PLUG BRACKET	1
23	NUT NYLOC HEX HD M4x0.7P	2
24	SET SCREW HD M6x16x1.0P	2
25	WASHER FLAT M6x12.5xX1.2	2
26	CLIP NUT 6MM	2
27	HITCH BOX COLLAR COVER	1
28	"D" SHACKLE 10mm	2
29	TOWBALL 50mm	1
30	SMART PIN SILVER	1
31	COMPLIANCE LABEL	1
32	LOAD RATING LABEL	1
33	CAN MODULE WARNING LABEL	2
34	WIRING LOOM	1



LOCATION DIAGRAM AND WIRING ASSEMBLY DIAGRAM

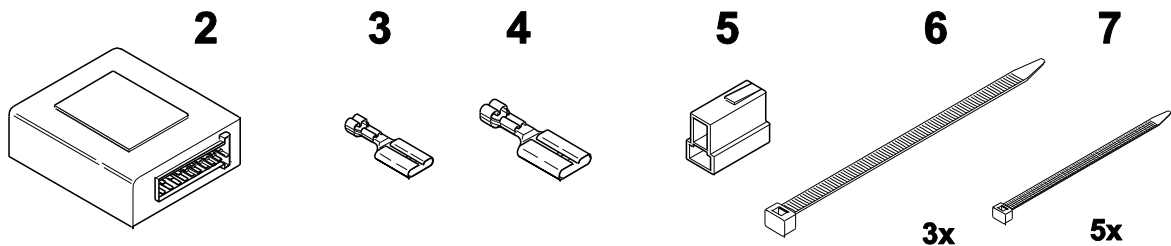
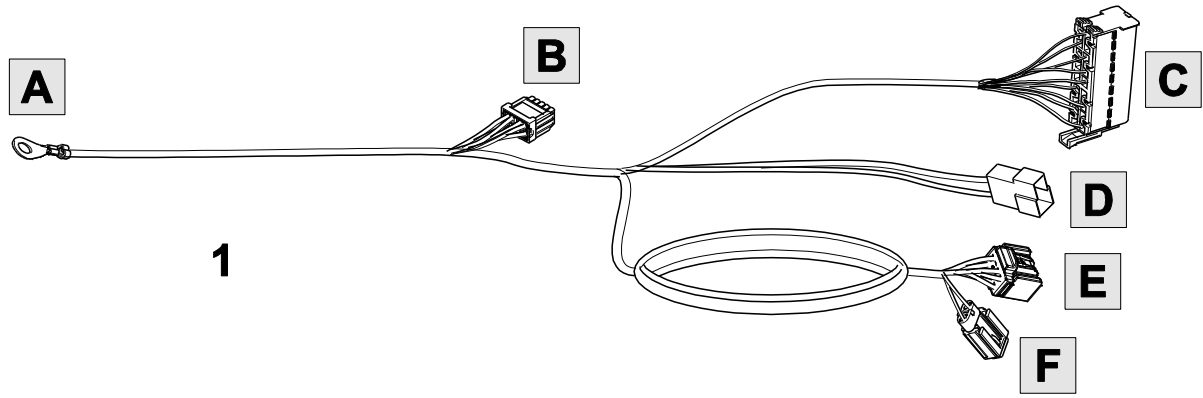

ITEM	DESCRIPTION	QTY
1	TRAILER PATCH HARNESS	1
2	TRAILER ECU (WLE70010)	1
3	F. CONTACT 6,30MM/1,00mm ² (BRAKE PREP CONNECTOR)	1
4	F. CONTACT 6,30MM/2,50mm ² (BRAKE PREP CONNECTOR)	1
5	2-WAY F. CONNECTOR 6.3MM (BRAKE PREP CONNECTOR)	1
6	300mm CABLE TIE	3
7	150mm CABLE TIE	5

-
1. On underside of bumper remove 2 x screws.

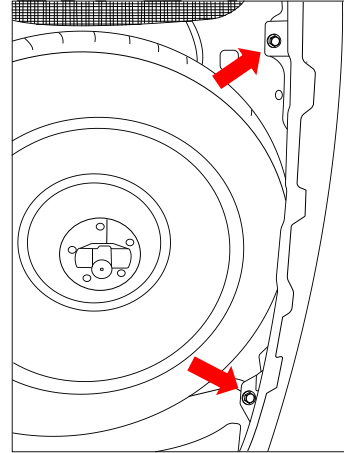

-
2. Remove and set aside the centre outer skin of the bumper to expose 2 x screws.
(There are 4 retaining clips along the top edge of the skin that can be manipulated from the inside of the bumper)
 3. Remove the exposed 4 x screws.

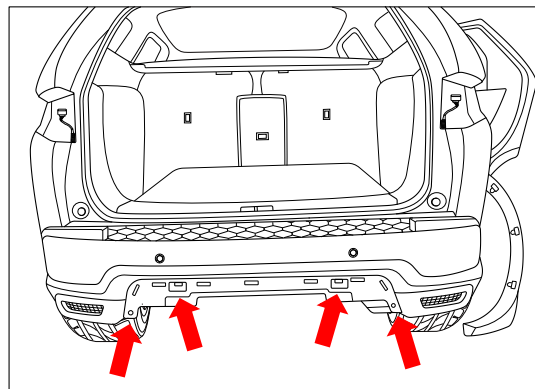

-
4. In wheel arch remove 1 x scrivet and 2 x screws.

Repeat for other side.

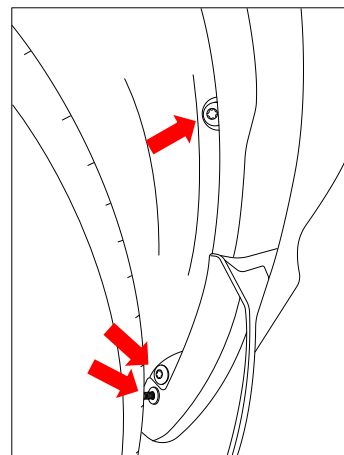

5. Unclip and peel away wheel arch trim to reveal bolt.
6. Remove 1 x bolt.

Repeat for other side.

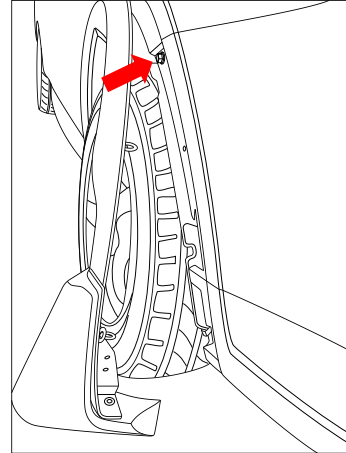

7. In luggage compartment remove the LH trim cover and the RH vent to gain access to the taillight mounting screws.

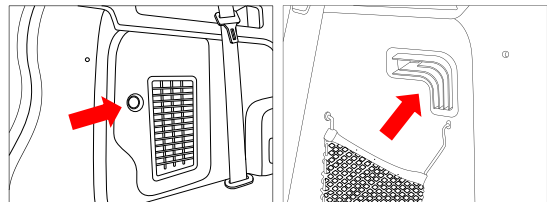

8. Remove 1 x spring screw securing the taillight.
9. Push plastic clip upwards to release the taillight from its installed position.

Repeat for other side.

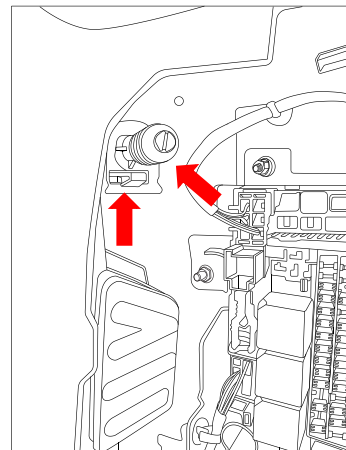

10. Unplug and remove taillight from vehicle (slides out easily rearwards).
11. Remove the exposed 1 x screw and 1 x bolt from the bumper.

Repeat for other side.

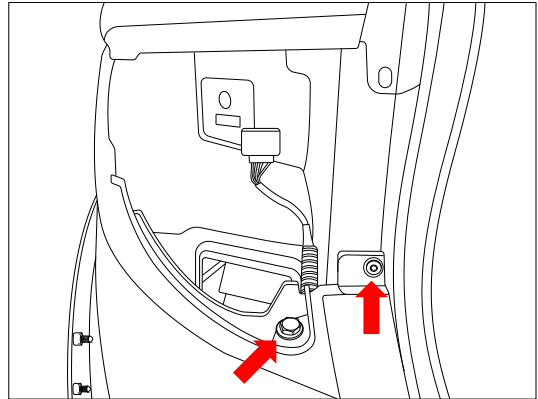

12. Peel away bumper from the sides and remove from vehicle. Ensure to disconnect the wiring harness located on the RH side.

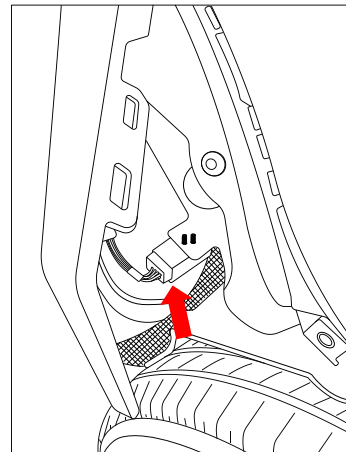

13. On the RH side, remove the AdBlue tank protector plate secured, forward of tank, with 2x nuts on studs (indicated in image) and, rearward of tank, with 1 x bolt connected to impact beam.

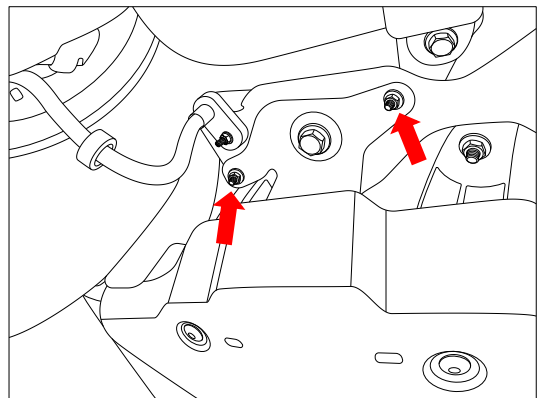

-
14. Loosen and drop the AdBlue tank by removing 2 x nuts from the impact beam, 1 x nut from the RH side and 1 x nut on stud from the front underside.

NOTE: The tank does not have to be fully removed for the installation. You may have to support it with a strap if necessary.

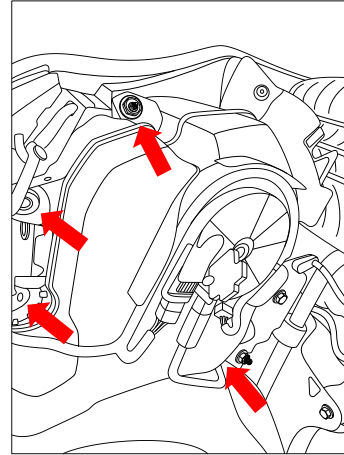

-
15. On the LHS, drop the exhaust by removing the rubber mounts from the exhaust hanger brackets.
16. If required, remove the heat shield to gain access to the mounting holes on the underside of the chassis rail.

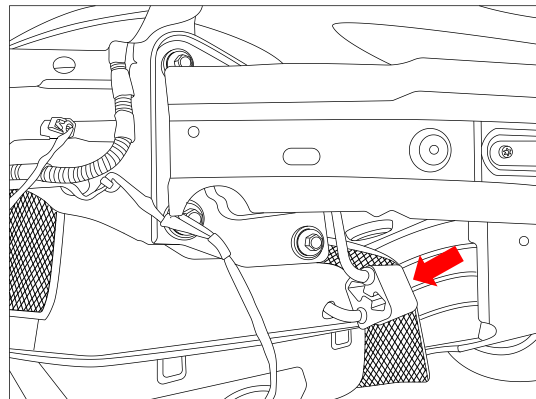

-
17. Remove the key antennae along with the wiring loom from the impact beam secured with 2 x screws.
18. Remove and dispose the impact beam from the vehicle secured with 3x bolts per side.

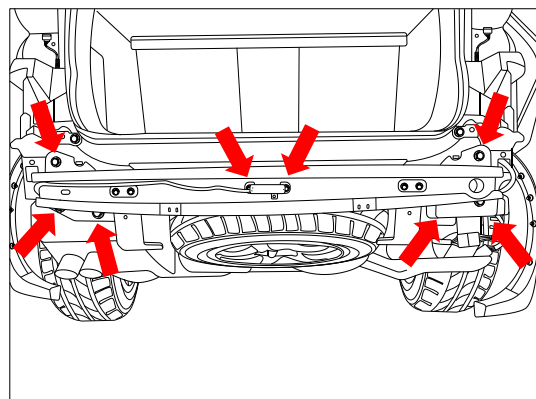

19. On the RH side, remove and dispose the recovery hook secured with 2 x bolts.

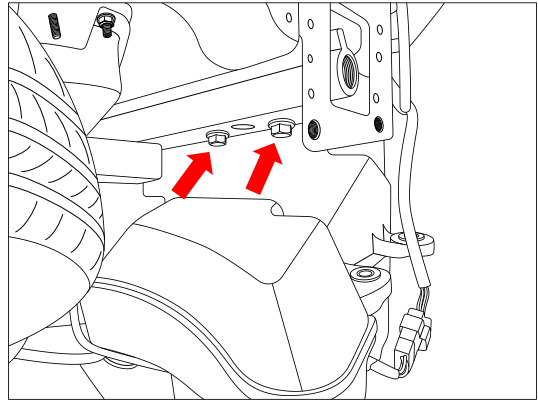

20. Insert the side arm assembly into the chassis rail and loosely secure from the bottom with 4 x M14 bolts complete with 1 x washer per bolt. (The AdBlue tank may have to be manipulated a little to allow access for bolt installation).

Repeat for the other side.

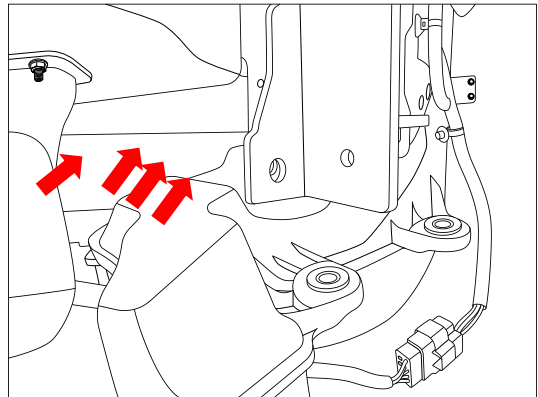

21. Loosely secure the RH side arm assembly along with the AdBlue mounting bracket to the back panel with 3 x M10 bolts complete with 1 x washer per bolt.

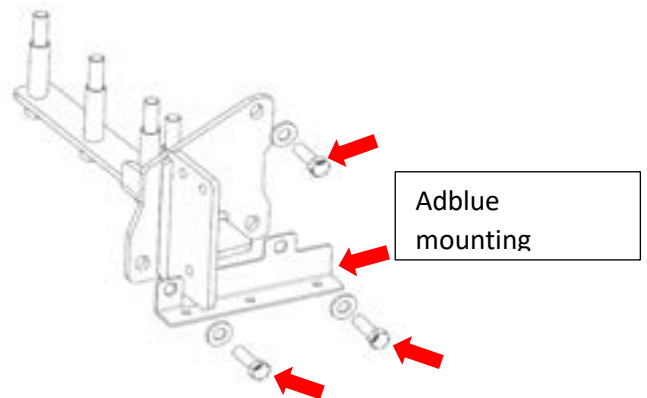

-
22. Loosely secure the LH side arm assembly along with the exhaust hanger bracket to the back panel with 3 x M12 bolts complete with 1 x washer per bolt.

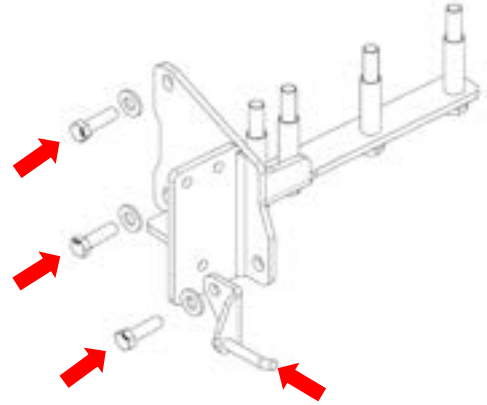

-
23. Position the crosstube assembly up to the side arm assemblies and loosely secure each side with 3x M12 bolts complete with 2x washers and 1x nut per bolt.

NOTE: Use the supplied spacers (1 per side) to eliminate excess clearance between the side arms and the crosstube if required.

24. Position the parts and tighten all fasteners to the following torque:

M10 x 1.25 : 48Nm

M12 x 1.75 : 78Nm

M14 x 2 : 124Nm

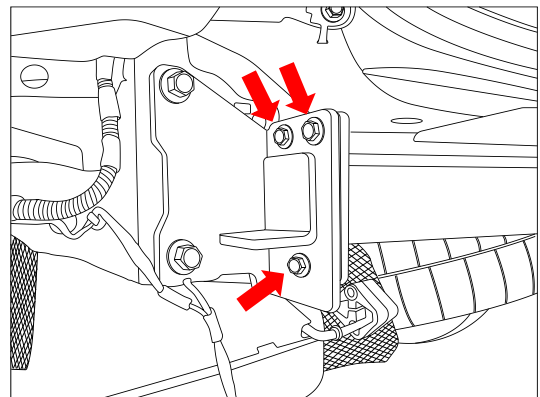

-
25. Loosely secure the LH and RH bumper tabs to the crosstube assembly with 1 x Tek screw per bracket.

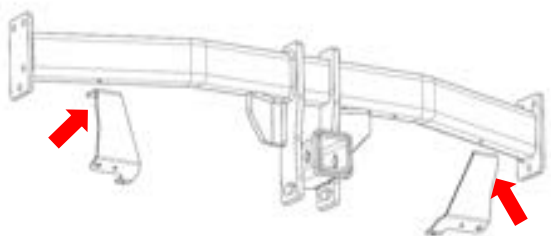

-
26. Refit the AdBlue tank back in position (step 14). Use the provided 2 x M8 bolts complete with 2 x washers and 1 x Nut per bolt to replace the original impact beams stud locations.

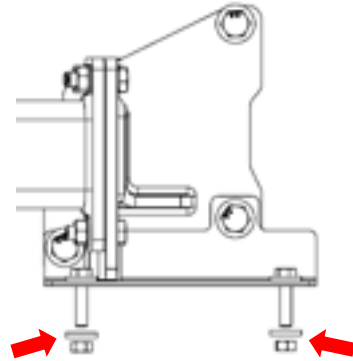

-
27. Refit the AdBlue tank protector plate back in position (step 13). Use the provided 1 x M8 bolt complete with 2 x washers and 1 x Nut per bolt to replace the original impact beam bolt to weld nut location.

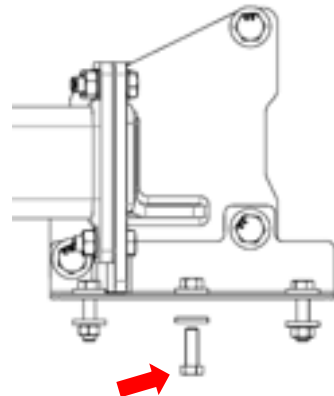

-
28. Refit the removed key antennae sensor from the impact beam (step 17) to the top of the crosstube assy and secure with the provide 2x Tek screws. Cable tie (not provided) the wiring harness to the crosstube.

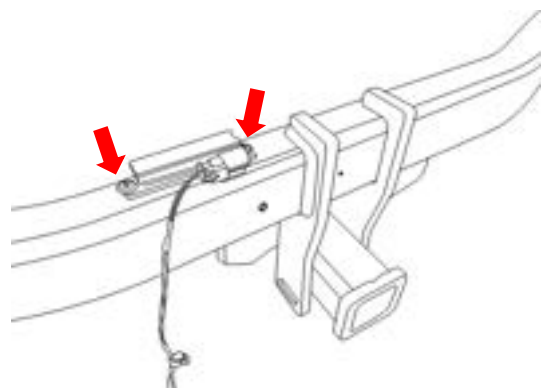

29. For inner skin bumper cut:

On the bumper inner skin, determine the centre of the bumper and cut a relief passage approximately 100mm wide and 20mm high to clear the towbar droppers.

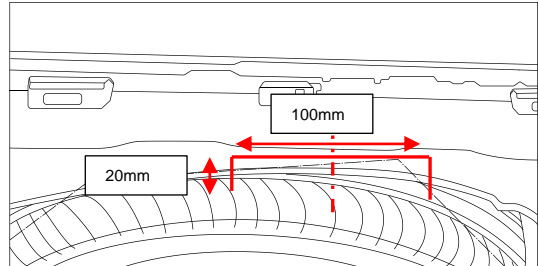

30. For Bumper cut:

Identify the centre line of the bumper. Measure, mark out and cut a section 96mm wide (48mm either side of the bumper centreline) and approximately 120mm long measured from the bottom edge of the bumper (follow bumper profile).

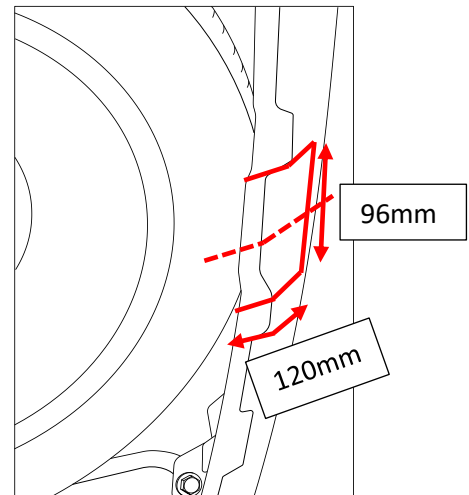

31. For plug bracket:

Determine a suitable position, mark out and drill 2 x Ø5mm holes 69mm apart on bumper skin to support plug bracket.

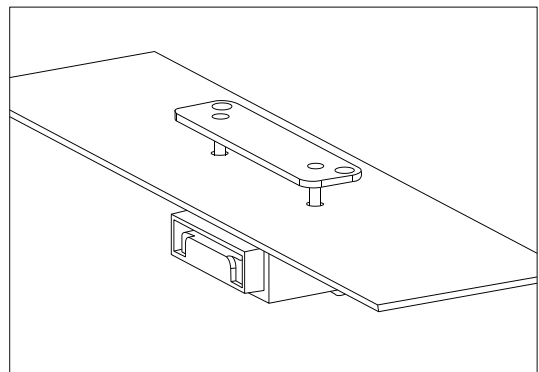

32. Open the rear tail gate and remove the keys from vehicle.
33. Remove the rear luggage compartment floor trim.
34. Remove the rear luggage compartment sill trim.

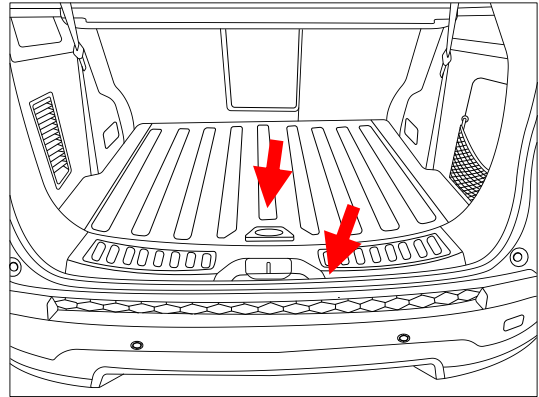

35. Remove the foam tool tray.

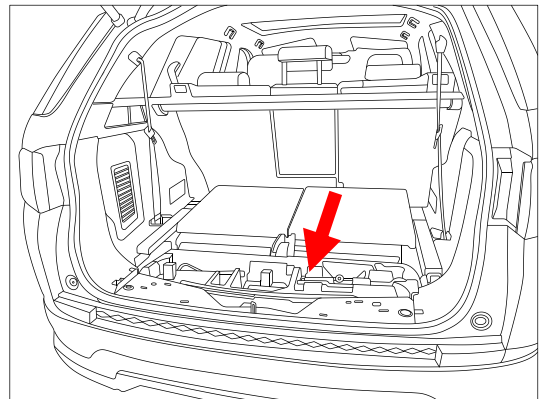

36. Measure 50mm from centre of vehicle grommet towards the front of the vehicle.
37. Measure 50mm from centre of grommet towards LHS of vehicle.
38. Using a step drill, drill a $\text{Ø}30\text{mm}$ hole.
39. Remove all sharp edges and spray rust inhibitor.

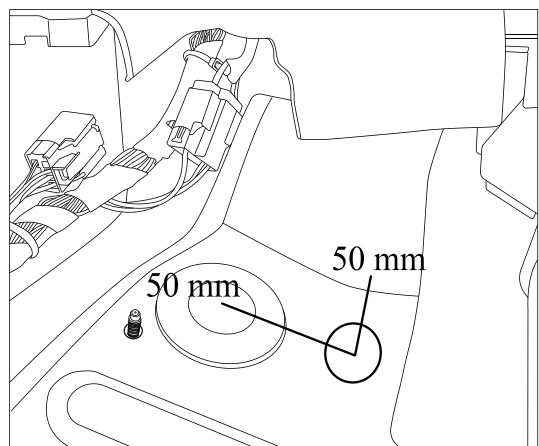

CAUTION

Before drilling:

- Ensure clearance between spare tyre and exhaust shield is checked.

40. From outside the vehicle route and secure the tail harness (1200mm) to the towbar allowing enough length to later secure to plug bracket.
41. Slide the grommet to desired location and secure with cable tie.

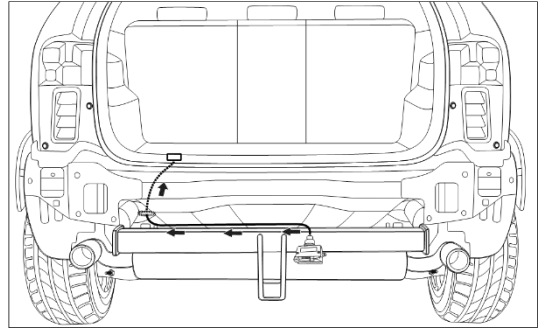

42. Connect the trailer patch ring terminal (A) to factory ground point.

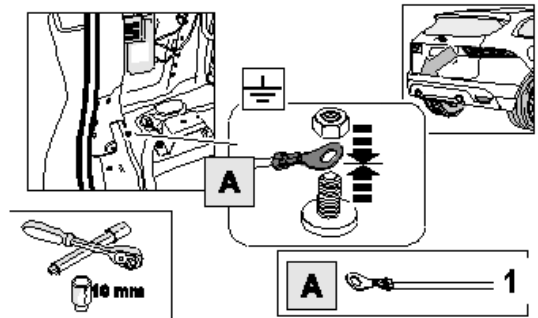

43. Locate the vehicle 8-way Pre-wire and connect the trailer patch harness mating connector (E).

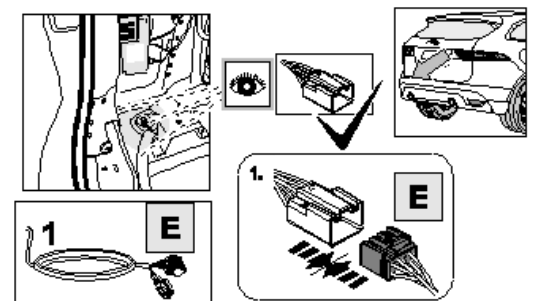

44. Plug the trailer patch (1) 18-way connector (C) into the ECU (2).
45. Peel the backing off the adhesive tape from the rear of the ECU.
46. Mount the ECU in location shown.

Ensure the tape has good adhesion.

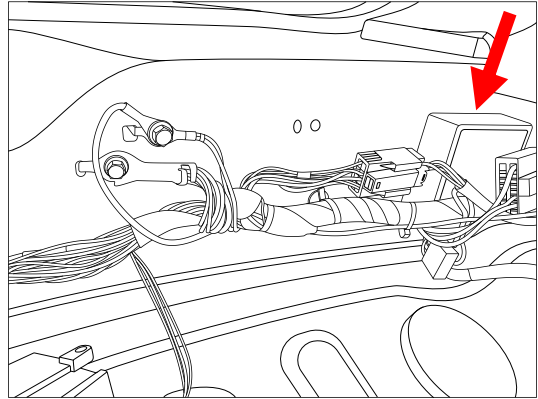

47. Plug the trailer patch blue connector (B) to mating 1200mm tail connector.

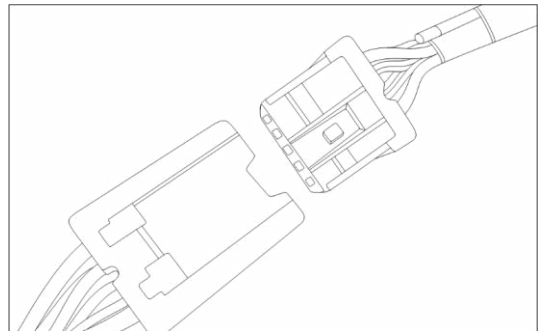

48. Reinstall all removed parts in reverse.
Use the provided M6 bolts complete with 1x washers and 1 nut clip to secure the bumper to the bumper tab (LH and RH side).
49. Position and secure the the LH and RH bumper tab with the Tek Screw.
50. Test the trailer functionality with a test board.
51. Place fitting instructions in the glovebox when finished.

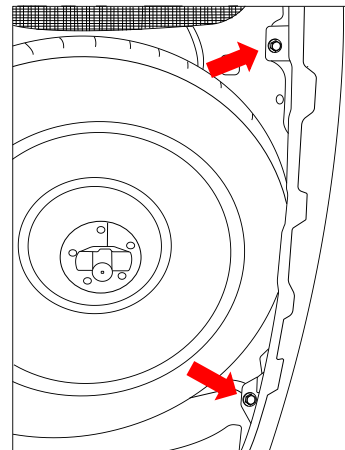



CUSTOMER INFORMATION

PLACE THESE INSTRUCTIONS IN THE VEHICLE'S GLOVEBOX AFTER INSTALLATION

THANK YOU FOR PURCHASING TRAILBOSS. WITH CORRECT MAINTENANCE AND CARE THIS PRODUCT WILL PROVIDE A LIFETIME OF TROUBLE-FREE OPERATION.

TOWBAR MAINTENANCE AND CARE:

- Trailboss recommend that the towbar LUG or TBM (Trailer Ball Mount) Pull Pin and R-clip are removed and stored when not in use. Removal of LUG or TBM (Trailer Ball Mount) is advisable when not in use to assist with any of the following.
 - Ensure rear number plate is not obscured.
 - Allow maximum available departure angle and prevent any potential interference.
 - Prevent possible interference with vehicles reverse sensors or camera detecting a tow ball mount as an obstruction during reversing.
 - Removes towball mount as an obstruction for when moving around the rear of the vehicle.
- Trailboss recommends routine inspection of your towbar to ensure trouble free towing.
 - Bolt security and tension should be regularly inspected and checked for correct tension. Replace any worn or defective parts with suitable grade & class fasteners. Inspection should be requested to coincide with vehicle major services.
- It is the owner's responsibility to ensure towing and down ball weight capacities of the towing vehicle are not exceeded.
 - Towing and down ball weights allowable may differ according to model variations. Please refer to owner's manual or vehicle dealer to confirm exact rating for your vehicle model variant.
 - It is not uncommon for the vehicle tow rating to differ from the towbar rating. When this occurs, the lesser rating must be adhered to.
 - For vehicles fitted with enhanced vehicle functions that may be altered/changed when towing i.e Trailer sway mitigation, blind spot detection, adaptive cruise control etc. Please consult owner's manual to understand changes enabled when towing and after towing.

WARRANTY INFORMATION:

Trailboss Towbars are covered by a Lifetime Warranty.

Our goods come with guarantees that cannot be excluded under the Australian Consumer Law. You are entitled to a replacement or refund for a major failure and for compensation for any other reasonably foreseeable loss or damage. You are also entitled to have the goods repaired or replaced if the goods fail to be of acceptable quality and the failure does not amount to a major failure.

For further details please contact customer service on 1800 812 017.

PRO SERIES SILENT ANTI-RATTLE HITCH PIN

Your Trailboss towbar is equipped with a Pro Series Silent Anti-Rattle Hitch Pin technology to help reduce towbar tongue rattle in most driving conditions. Please ensure below instructions are understood and routine maintenance is carried out to ensure best towing experience.

Regularly inspect for wear and check the tightness of the Silent Anti-Rattle Hitch Pin. Follow instructions below to re-tighten the nut as necessary when movement and noise in the tow ball mount is noted.

- Before towing, ensure R-Clip is properly installed and hitch pin nut is installed and tensioned. Replacement parts are available from your Pro Series Distributor.

TOWBALL MOUNT REMOVAL/INSTALLATION

STEP 1

Insert Trailer Ball Mount (TBM) (a) into towbar hitchbox (b), aligning hole in TBM shank (c) with hole in hitchbox (d) (Fig. 1)

STEP 2

Insert Silent Anti-Rattle Hitch Pin (e) through hole in hitchbox and hole in TBM shank (g); ensure the locators are inserted into the notches in the hitchbox (Fig. 2)

STEP 3

Screw Silent Anti-Rattle Hitch Pin Nut (f) onto Smart Pin (g); tighten Smart Pin Nut until finger tight, ensuring TBM is restrained from up and down movement.

STEP 4

Tighten Silent Anti-Rattle Hitch Pin Nut by turning nut a further 1/8th of a turn in the clockwise direction using a 24mm spanner (Fig. 4).

STEP 5

Install Silent Anti-Rattle Hitch Pin R-Clip through the hole that provides best clearance or easiest access. (Fig. 5)

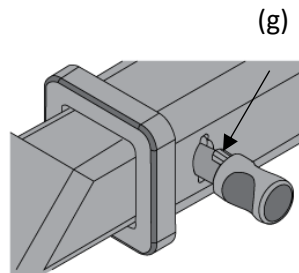
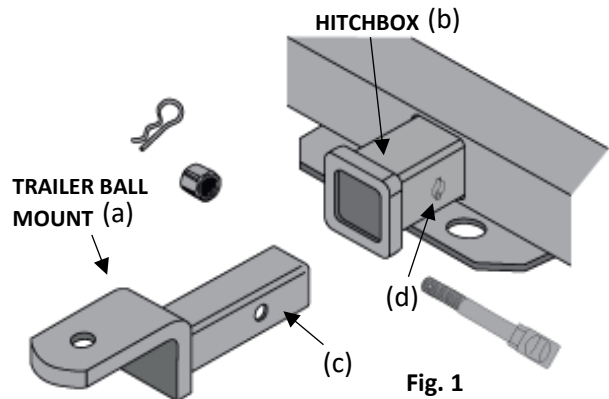

Fig. 2

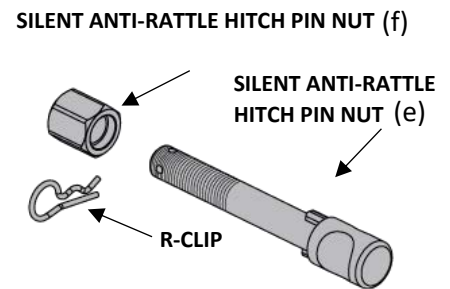

Fig. 3

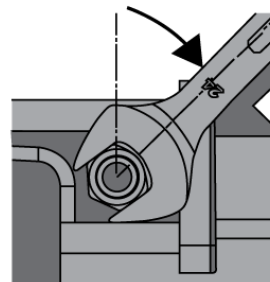

Fig. 4

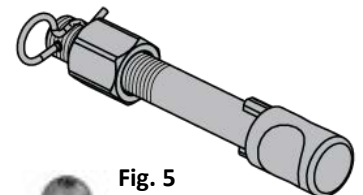

Fig. 5

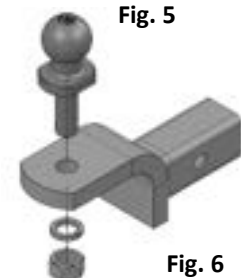

Fig. 6