

TRAILBOSS

Tow bar Fitting Instructions Part Number QTSB311L

To Suit Subaru MY09 Forester 03-2008-on To Suit Subaru Impreza Sedan 09-2008-on
Rating - Forester 1600-110 to 160Kg Rating - Impreza 1200-75Kg

Ensure that vehicle owner's manual is consulted for correct towing capacity

WARNING:

1. Do not, drill, cut, weld or otherwise modify the tow bar.
2. If you are using electric welding on a motor vehicle, **always** check that the vehicle is not equipped with electronic engine or instrument management equipment. Failure to do so could **destroy** any onboard computers. If in doubt, check with the vehicle's manufacturer.

General:

1. Ensure all hardware items have been included refer to assembly diagram.
2. It is recommended that the instructions are read through and completely understood before making any attempt to fit this product.
3. Be wary of any changes to vehicle designs or other accessories that may conflict with the installation of this product.
4. Before drilling ensure that the area is clear of fuel, electrical & other components.
5. All holes drilled into the body panels shall have all burrs & swarf removed then coated with a suitable rust preventative paint.
6. The high tensile fasteners supplied with this product were used to achieve the specified rating. If replacement is required ensure that fasteners of the same rating & quality are used. Contact an authorized **Trailboss** dealer if further information is required.
7. Ensure that all hardware is fastened to torque list below check fasteners on regular basis.
8. Tow bar load rating sticker provided with this product shall be conspicuously located on inside rear end of the driver's door. **(See diagram below).**
9. Trailboss recommends that you check your tow ball to ensure that it complies with the Australian standards **AS 4177.2**.
10. **PLEASE NOTE:** It is advised to remove your lug or tbn when not actually towing so as to produce a clear view of the vehicles registration plate if obscured, and to also provide maximum available departure angle

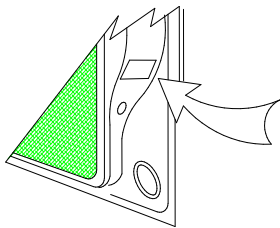

Place load rating sticker
inside driver's door here

FOR TOWING PURPOSES ONLY

For towing capacity details please refer to vehicle owner's manual or to the manufacturer. Overloading can void your warranties.

RECOMMENDED ASSEMBLY TORQUE LISTING

Diameter Grade 8.8 Bolt

M6	9.5 Nm
M8	21.7 Nm
M10	43.4 Nm
M12	77.3 Nm
M16	189.8 Nm

Tow bar Maintenance and Care.

Trailboss recommends that bolt torque's, as listed below, are routinely and regularly inspected and checked for correct tension. Replace any worn or defective parts.

We recommended to remove Tow Ball Mounts (TBM's, tongues or lugs) when not being used for any considerable length of time.

So as to avoid injury, when not towing it is suggested that the tongue, Pull Pin and R-clip are removed then stored in a safe, clean and dry place, away from excessive moisture.

Hitch Pull Pins and spring "R" clips are regularly checked for proper installation. Replace any worn or defective parts.

Tow bar Fitting Instructions Part Number QTSB311L

To Suit Subaru MY09 Forester 03-2008-on To Suit Subaru Impreza Sedan 09-2008-on
Rating - Forester 1600-110 to 160Kg Rating - Impreza 1200-75Kg

11. Remove rear bumper bar skin via

- Remove 2 x plastic trim buttons from underneath bumper bar see fig 1.
- Remove 2 x plastic trim button on the under side of guard see fig2.
- Remove 2 x screws in the tailgate cavity see fig 3 for Forester model only.
- Remove 3 x screws in the inner wheel arch each side of the vehicle see fig 4.
- Remove 1 x plastic trim bottom in the vertical plane see fig 5 for Forester model only.
- Remove 2 x plastic trim plugs from mud guards one on the inside of the mudguard & one in the vertical plane on the other side of the mudguard see figs 6 for Forester model only.
- Unplug the reverse parking assist sensors if fitted.
- Flex bumper bar skin out at the sides then pull rearward to remove **Caution** two person lift required some force may be required store bumper on suitable stands.

Remove 2 x plastic trim buttons from under side of bumper bar Forester model only



Fig 1

Remove 1 x plastic trim button from underside of bumper bar Impreza model only.

Remove 2 x plastic trim buttons from underside of mud guards.

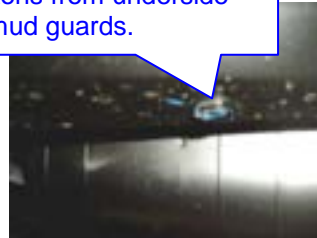

Fig 2

Remove 2 x screws from tailgate cavity one each side.



Fig 3

Remove 3 x screws from inside each wheel arch.



Fig 4

Forester model only

Remove 2 x plastic trim buttons in the vertical plane one each side of vehicle.

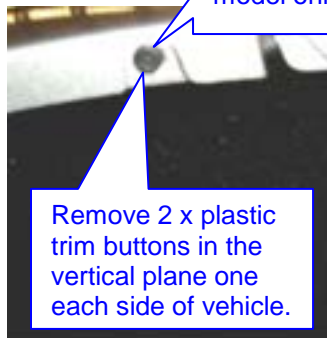

Fig 5

Remove 2 x plastic trim buttons from in side mud flap in the vertical plane one each side of the vehicle.



Fig 6

Forester model only

12. Remove rear impact beam via

- Remove 6 x M10 nuts retaining the impact beam then discard the nuts see fig 7.
- Pull the impact beam rearwards to remove then discard the beam see fig 7.
- Lower the two rear most mufflers from the 5 rubber exhaust hangers see fig 8.

Rear impact beam remove & discard.



Fig 7

Remove 6 x M10 nuts retaining impact beam then discard bolts.



Fig 8

Lower the two rear mufflers by removing the rear rubber hangers in 5 places then let mufflers hang.

TRAILBOSS

Tow bar Fitting Instructions Part Number QTSB311L

To Suit Subaru MY09 Forester 03-2008-on To Suit Subaru Impreza Sedan 09-2008-on
Rating - Forester 1600-110 to 160Kg Rating - Impreza 1200-75Kg

13. Remove rubber grommets via

- Remove 2 x rubber grommets from the underside of the chassis rails two each side of the vehicle then discard the grommets see fig 9.
- If required drill out holes either side of the vehicle 13mm see fig 10



Remove 2 x rubber grommets from each side of the vehicle then discard.

Fig 9

Drilling is only required for vehicle variation test fit bar first before drilling.



Drill out holes 13mm in four places if required.

Fig 10

14. Fitment of tow bar to vehicle via

- Fit loose 3mm plates to rear panel of vehicle so that holes align with studs see fig 11.
- Offer tow bar to vehicle sub frame so that captive nuts on side plates align with existing holes in chassis rails see fig 10 & fig 12.
- Fit loose plates M12 x 35 bolts & spring washers provided loosely see fig 13.
- Fit M10 x 1.25P whizz nuts to the rear studs of the vehicle see figure 14 fasten all hardware to the torque listing.



Fit 3mm loose plates

Fig 11



Offer tow bar to sub frame

Fig 12



Fit loose plates spring washers with M12 bolts

Fig 13

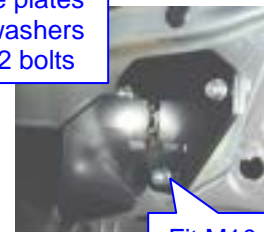

Fit M10 x 1.25P whizz nuts

Fig 14

15. Rear bumper bar cut detail for Forester model only.

- Place masking tape over the on centre section of bumper bar before marking out as shown in fig 15.
- Mark out as shown in fig 15 then cut with suitable hacksaw or similar device.
- Ensure that all swarf & raw edges are removed.
- Refit the bumper bar in the reverse of steps 11 h through to 11a.
- Fit trailer ball mount part number 21161 with pull pin & R clip.

Fig 15

Ensure that corners are cut with 10 mm radius & filed clean.

Establish centre line of the bumper bar then measure out 45mm from centre line each side so that cut is 90mm wide.

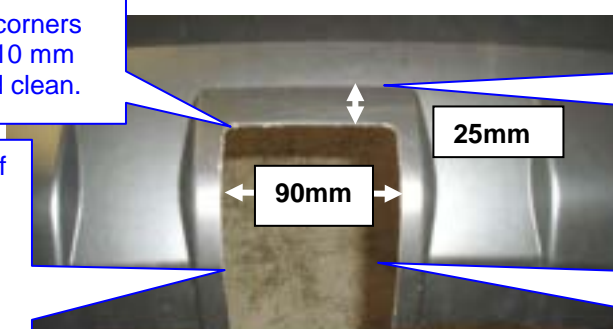

Measure down 25mm from top of indent as shown then mark with suitable marker

Area of bumper bar to be removed ensure that all swarf & burrs are removed

Tow bar Fitting Instructions Part Number QTSB311L

To Suit Subaru MY09 Forester 03-2008-on To Suit Subaru Impreza Sedan 09-2008-on
Rating - Forester 1600-110 to 160Kg Rating - Impreza 1200-75Kg

16. Rear bumper bar cut detail for Impreza model only.

- Place masking tape over the on centre section of bumper bar before marking out as shown in fig 16 for Impreza model only.
- Mark out as shown in fig 16 then cut with suitable hacksaw or similar device.
- Ensure that all swarf & raw edges are removed.
- Refit the bumper bar in the reverse of steps 11 h through to 11a.
- Fit trailer ball mount part number 21161 with pull pin & R clip.

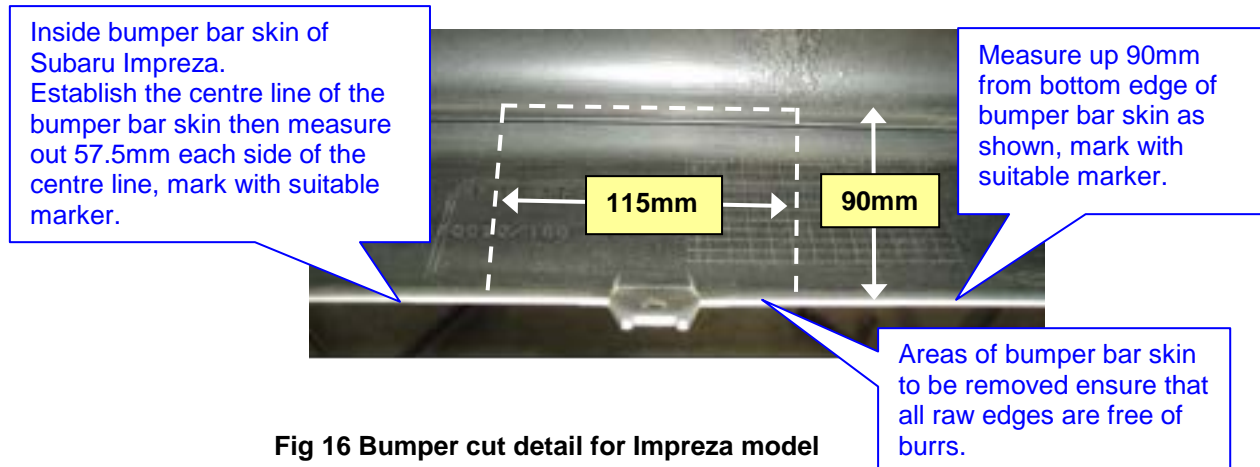
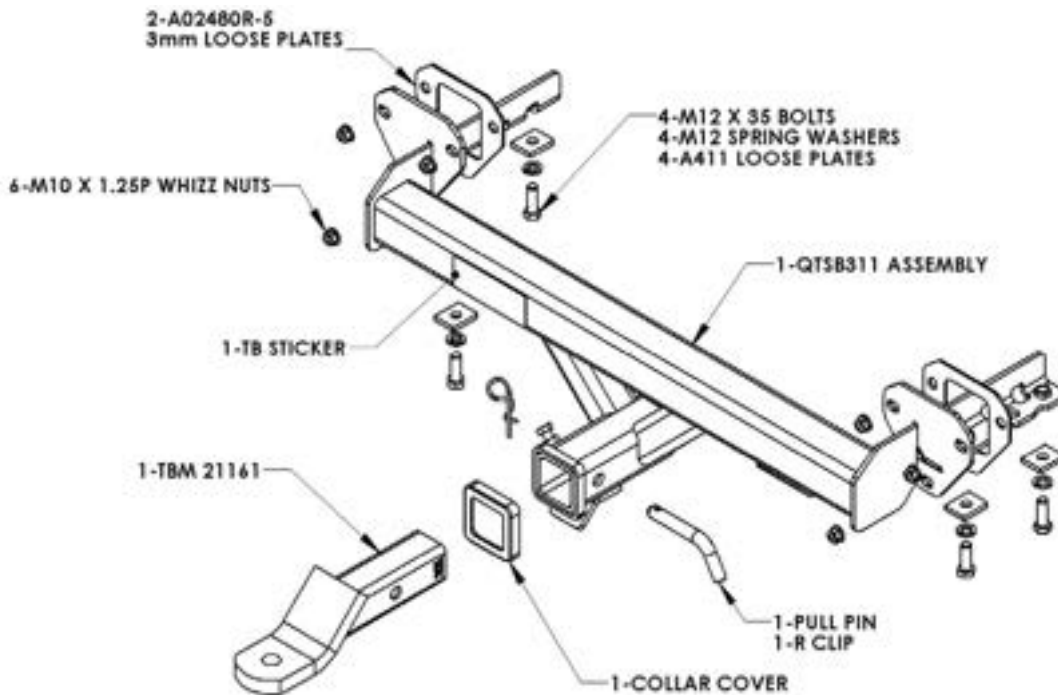

Fig 16 Bumper cut detail for Impreza model



TRAILBOSS

Tow bar Fitting Instructions
Part Number QTSB311L

To Suit Subaru MY09 Forester 03-2008-on To Suit Subaru Impreza Sedan 09-2008-on
Rating - Forester 1600-110 to 160Kg Rating - Impreza 1200-75Kg

Wiring Loom Installation Instructions

**SUBARU LIBERTY (SEDAN & WAGON),
OUTBACK & FORESTER**
Part No: 100201-WL

Tail Harness Length Required:
Liberty / Outback - 1200mm (Wagon)
Liberty - 1800mm (Sedan)
Forester – 1800mm

RPA Override Switch Part No: 04848 (If Fitted)

Liberty Wagon, Outback & Forester - Page 2-5
Liberty Sedan - Page 6-8

Wiring Loom Installation Time: Approx 25 Mins

Note: The following steps are for wagon models only. For Liberty sedan Modes, see page 6.

1. In the luggage compartment area, remove the rear sun shade (1) and all floor trims (2). Remove the LHS and RHS tail lights (3). Remove the rear bumper fascia fasteners and the rear bumper fascia (4).

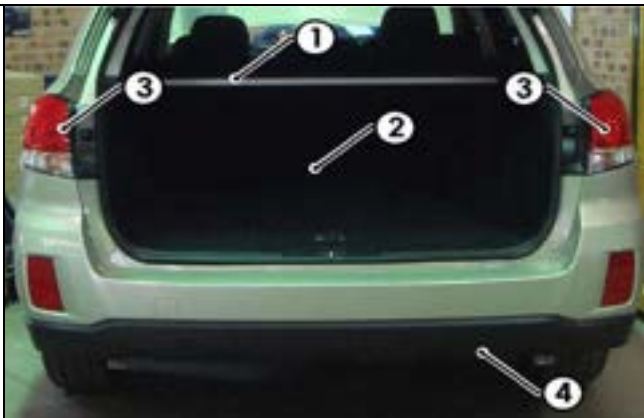

TRAILBOSS

Tow bar Fitting Instructions Part Number QTSB311L

To Suit Subaru MY09 Forester 03-2008-on To Suit Subaru Impreza Sedan 09-2008-on
Rating - Forester 1600-110 to 160Kg Rating - Impreza 1200-75Kg

2. Remove the rear trim (1).



3. Remove the rear passenger seat cushion (1).



4. Remove the LHS rear passenger sill trim (1).
Remove the two fasteners (2) from the LHS rear luggage compartment trim.



TRAILBOSS

Tow bar Fitting Instructions Part Number QTSB311L

To Suit Subaru MY09 Forester 03-2008-on To Suit Subaru Impreza Sedan 09-2008-on
Rating - Forester 1600-110 to 160Kg Rating - Impreza 1200-75Kg

The following step is for Outback & Liberty wagons only. For Forester models, go to Step 6.

5. Remove the LHS luggage compartment trim fasteners (1) and then remove the LHS luggage compartment trim (2).

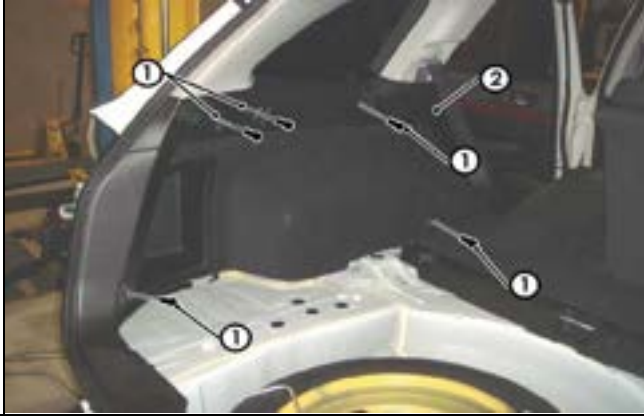

6. On the outer LHS rear quarter of the car, locate and remove the grommet near the vent. Widen the grommet hole (1) to Ø31mm using a step drill (2). File the grommet hole of any rough edges and spray with rust inhibitor.

Note: For vehicles fitted with sunroofs, drill a Ø2mm pilot hole in the area (3) below the sunroof drain. Drill out the hole to Ø31mm using a step drill. File any sharp or rough edges and spray on rust inhibitor.



7. Secure the Tail Harness socket (tail length 1200mm) (1) to the towbar mounting bracket using M4 fasteners (not supplied).



Tow bar Fitting Instructions Part Number QTSB311L

To Suit Subaru MY09 Forester 03-2008-on To Suit Subaru Impreza Sedan 09-2008-on
Rating - Forester 1600-110 to 160Kg Rating - Impreza 1200-75Kg

8. Route the Tail Harness (1) along the towbar and into the LHS rear quarter grommet.



9. Inside the luggage compartment LHS, retrieve the tail harness (1) from the grommet hole (2) ensuring that the tail harness grommet is seated correctly. Locate and free the vehicle 10-way female break out connector (3). Connect the Trailer Patch Harness (100201-WL) (4) to the tail harness (1). Connect the trailer patch harness to the break out connector (3).

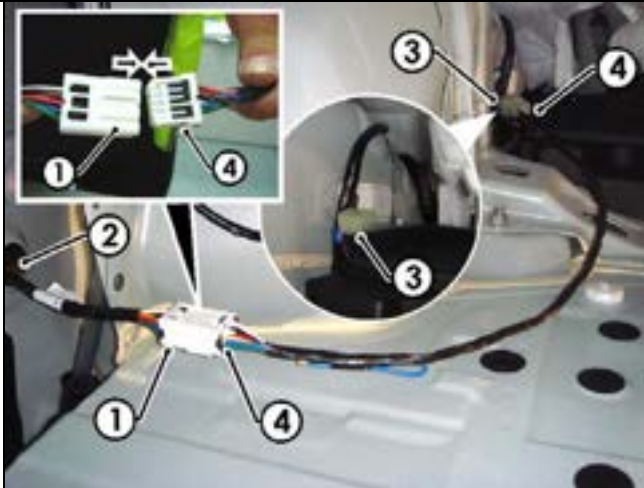

10. Test the Trailer Harness function using a Light Board or multimeter.
11. Secure all Harnesses using cables ties (not supplied).
12. Re-fit all removed parts and secure all fasteners, ensuring there are no squeaks or rattles.
13. Place instructions in glove box after fitment.

TRAILBOSS

Tow bar Fitting Instructions Part Number QTSB311L

To Suit Subaru MY09 Forester 03-2008-on To Suit Subaru Impreza Sedan 09-2008-on
Rating - Forester 1600-110 to 160Kg Rating - Impreza 1200-75Kg

Note: The following steps are for sedan models only.

1. Remove the rear bumper from the vehicle. Remove the luggage compartment floor carpet (1).



2. Remove the rear trim (1) by removing the indicated fasteners (2).

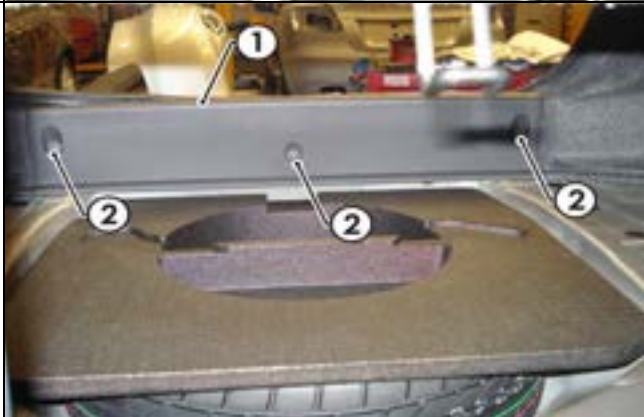

3. Remove the LHS luggage compartment trim (1) by removing the two fasteners (2).



Tow bar Fitting Instructions Part Number QTSB311L

To Suit Subaru MY09 Forester 03-2008-on To Suit Subaru Impreza Sedan 09-2008-on
Rating - Forester 1600-110 to 160Kg Rating - Impreza 1200-75Kg

4. On the outer LHS rear quarter of the car, locate and remove the grommet near the vent (in between the rear wheel arch and the vent). Widen the grommet hole (1) to $\text{\O}31\text{mm}$ using a step drill. File the grommet hole of any rough edges and spray with rust inhibitor.

Note: For vehicles fitted with sunroofs, drill a $\text{\O}2\text{mm}$ pilot hole in the area (3) below the sunroof drain. Drill out the hole to $\text{\O}31\text{mm}$ using a step drill. File any sharp or rough edges and spray on rust inhibitor.



5. Secure the Tail Harness socket (tail length 1800mm) (1) to the towbar mounting bracket using M4 fasteners (not supplied).

This box is intentionally blank

6. Route the Tail Harness (1) along the towbar and into the LHS rear quarter grommet (2).

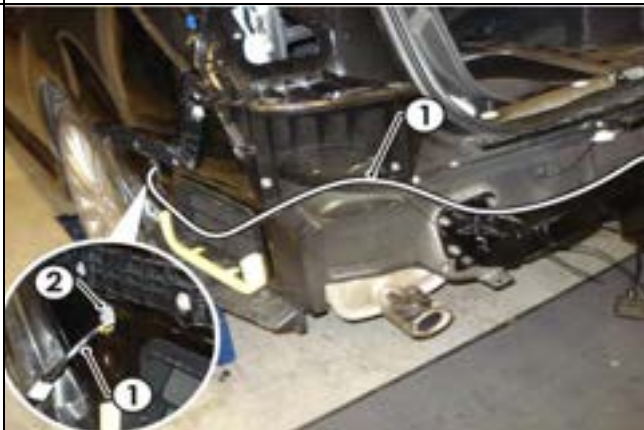

TRAILBOSS

Tow bar Fitting Instructions Part Number QTSB311L

To Suit Subaru MY09 Forester 03-2008-on To Suit Subaru Impreza Sedan 09-2008-on
Rating - Forester 1600-110 to 160Kg Rating - Impreza 1200-75Kg

7. Slide the Tail Harness grommet into the desired position, ensuring that it is seated correctly into the vehicle grommet hole. Secure with a cable tie (not supplied).
8. Connect the Tail Harness 10-way connector into the Trailer Patch Harness (P/no: 100201-WL) 10-way mating connector.
9. Route the Trailer Patch Harness towards the vehicle break out connector, located at the rear of the vehicle near the LHS of the wheel well.



10. Connect the Trailer Patch Harness (1) to the vehicle break out connector (2).
11. Re-fit the rear bumper fascia. Secure all harnesses to the vehicle using cable ties (not supplied).
Test the Trailer Harness function using a trailer light board or multimeter.
12. Re-fit all removed parts and secure all fasteners.
13. Please place the fitting instructions in the glove box after installation.

