

# TRAILBOSS

## Towbar Fitting Instructions To Suit **SUBARU LIBERTY 6<sup>TH</sup> GEN CLASS 4** Part Number **QTSB318L** Rating **1800/180 kg**

PLACE THESE INSTRUCTIONS IN THE VEHICLE'S GLOVEBOX AFTER INSTALLATION IS COMPLETED

### **WARNING:**

1. Do not, drill, cut, weld or otherwise modify the tow bar.
2. If you are using electric welding on a motor vehicle, **always** check that the vehicle is not equipped with electronic engine or instrument management equipment. Failure to do so could **destroy** any onboard computers. If in doubt, check with the vehicle's manufacturer.
3. The high tensile fasteners supplied with this product were used to achieve the specified rating. If replacement is required ensure that fasteners of the same rating & quality are used. Contact an authorised **Trailboss** dealer if further information is required.
4. If TBM is used in inverted position tow ball may make contact with rear tailgate when lowered, which could cause damage.

### **General:**

1. Ensure all hardware items have been included refer to assembly diagram.
2. It is recommended that the instructions are read through and completely understood before making any attempt to fit this product.
3. Be wary of any changes to vehicle designs or other accessories that may conflict with the installation of this product.
4. Before drilling ensure that the area is clear of fuel, electrical & other components.
5. All holes drilled into the body panels shall have all burrs & swarf removed then coated with a suitable rust preventative paint.
6. For vehicles that require the bumper to be cut. Ensure cut out area is in correct position on the vehicle prior to cutting the bumper.
7. The high tensile fasteners supplied with this product were used to achieve the specified rating. If replacement is required ensure that fasteners of the same rating & quality are used. Contact an authorized **Trailboss** dealer if further information is required.
8. Ensure that all hardware is fastened to torque list below check fasteners on regular basis.
9. Tow bar load rating sticker provided with this product shall be conspicuously located on inside rear end of the driver's door. **(See diagram below).**
10. Trailboss recommends that you check your tow ball to ensure that it complies with the Australian standards **AS 4177.2**.
11. **PLEASE NOTE:** It is advised to remove your LUG or TBM when not actually towing so as to produce a clear view of the vehicles registration plate if obscured, and to also provide maximum available departure angle

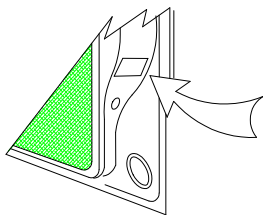

Place load rating sticker  
inside driver's door here

**FOR TRAILER TOWING PURPOSES ONLY**  
For towing capacity details please refer to vehicle owner's manual or to the manufacturer. Overloading can void your warranties.

### RECOMMENDED ASSEMBLY TORQUE LISTING

Diameter	Grade 8.8 Bolt
M6	9.5 Nm
M8	21.7 Nm
M10	43.4 Nm
M12	77.3Nm
M14	146 Nm
M16	189.8 Nm

### **Tow bar Maintenance and Care.**

Trailboss recommends that bolt torque's, as listed below, are routinely and regularly inspected and checked for correct tension. Replace any worn or defective parts.

We recommended to remove Tow Ball Mounts (TBM's, tongues or lugs) when not being used for any considerable length of time.

So as to avoid injury, when not towing it is suggested that the tongue, Pull Pin and R-clip are removed then stored in a safe, clean and dry place, away from excessive moisture.

Hitch Pull Pins and spring "R" clips are regularly checked for proper installation. Replace any worn or defective parts.

### **Cequent Customer Service**

Ph: 1800 812 017 Fax: 03 9898 3299

Email: [info@cequent.com.au](mailto:info@cequent.com.au)

Post: PO Box 4050, Dandenong South VIC 3175

# TRAILBOSS

Towbar Fitting Instructions  
 To Suit **SUBARU LIBERTY 6<sup>TH</sup> GEN CLASS 4**  
 Part Number **QTSB318L**  
 Rating **1800/180 kg**

PLACE THESE INSTRUCTIONS IN THE VEHICLE'S GLOVEBOX AFTER INSTALLATION IS COMPLETED

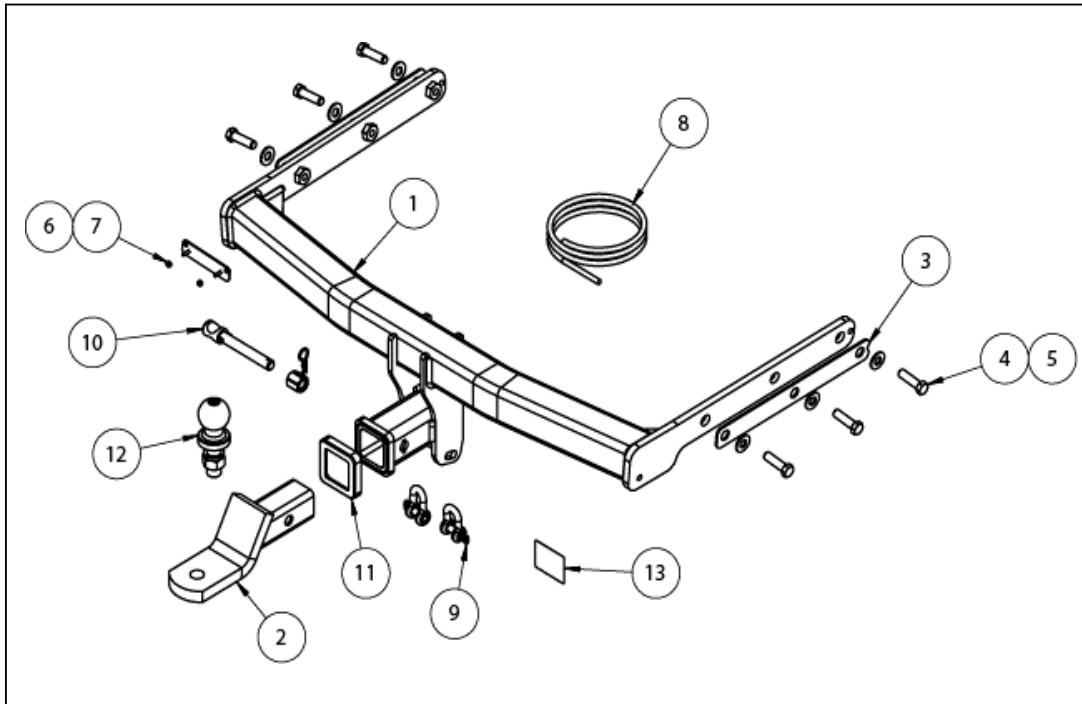

ITEM	DESCRIPTION	QTY
1	SUBARU LIBERTY WELDED TOWBAR	1
2	CLASS 4 TBM	1
3	SPACER PLATE	2
4	BOLT M12 x 45 1.75P	6
5	WASHER FLAT M12	6
6	PLUG BRACKET	1
7	NUT NYLOC M4-0.7 Z/P	2
8	WIRING LOOM	1
9	"D" SHACKLE 10MM	2
10	SILENT HITCH PIN – SILVER	1
11	HITCH BOX COLLAR COVER	1
12	TOWBALL 50MM	1
13	ACRYLIC COMPLIANCE LABEL	1

**Cequent Customer Service**  
 Ph: 1800 812 017 Fax: 03 9898 3299  
 Email: [info@cequent.com.au](mailto:info@cequent.com.au)  
 Post: PO Box 4050, Dandenong South VIC 3175

# TRAILBOSS

Towbar Fitting Instructions  
To Suit **SUBARU LIBERTY 6<sup>TH</sup> GEN CLASS 4**  
Part Number **QTSB318L**  
Rating **1800/180 kg**

PLACE THESE INSTRUCTIONS IN THE VEHICLE'S GLOVEBOX AFTER INSTALLATION IS COMPLETED

1. Remove 3x Screws from the LHS mud flap on the inside of the wheel arch.

Remove 1x Scrivet located on the underside of the mud flap cover, and place the mud flap aside.

Repeat for RHS.



2. Remove 1x pop Scrivet from the top of the LHS wheel arch.

Repeat for RHS.



3. Remove 7x Scrivets from the underside of the bumper.

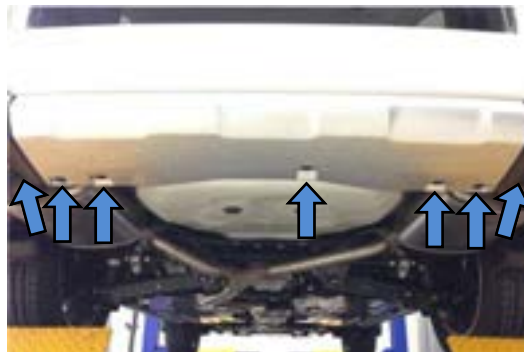

**Cequent Customer Service**

Ph: 1800 812 017 Fax: 03 9898 3299

Email: [info@cequent.com.au](mailto:info@cequent.com.au)

Post: PO Box 4050, Dandenong South VIC 3175

# TRAILBOSS

Towbar Fitting Instructions  
To Suit **SUBARU LIBERTY 6<sup>TH</sup> GEN CLASS 4**  
Part Number **QTSB318L**  
Rating **1800/180 kg**

PLACE THESE INSTRUCTIONS IN THE VEHICLE'S GLOVEBOX AFTER INSTALLATION IS COMPLETED

4. Remove 2x Scrivets from the LHS taillight cover.

Set the taillight cover aside and remove 2x Screws from the LHS taillight.

Dislodge the LHS taillight, disconnect the wiring and remove the LHS taillight assembly.

Repeat for RHS.



5. Remove 1x Screw below the taillight on the LHS of the bumper.

Repeat for RHS.



6. Remove the Bumper via unclipping the sides and pulling firmly.

When removing the bumper, ensure any wiring is disconnected.

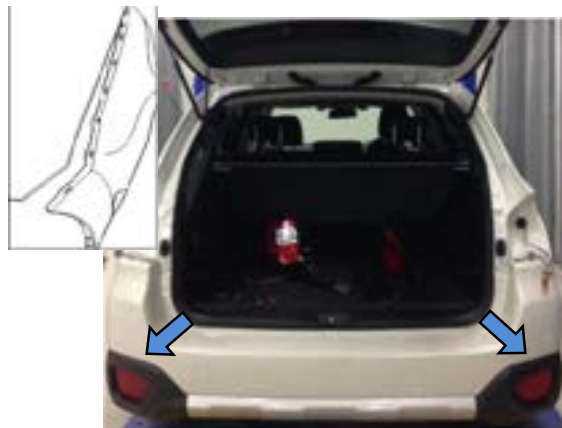

**Cequent Customer Service**

Ph: 1800 812 017 Fax: 03 9898 3299

Email: [info@cequent.com.au](mailto:info@cequent.com.au)

Post: PO Box 4050, Dandenong South VIC 3175

# TRAILBOSS

Towbar Fitting Instructions  
To Suit **SUBARU LIBERTY 6<sup>TH</sup> GEN CLASS 4**  
Part Number **QTSB318L**  
Rating **1800/180 kg**

PLACE THESE INSTRUCTIONS IN THE VEHICLE'S GLOVEBOX AFTER INSTALLATION IS COMPLETED

7. Remove 4 x Nuts on each side of the impact beam.

Discard the Impact Beam.



8. Unhook the two exhaust hangers for both LHS & RHS.

Remove 4x Screws retaining the LHS exhaust shield & set aside.

Repeat for RHS.

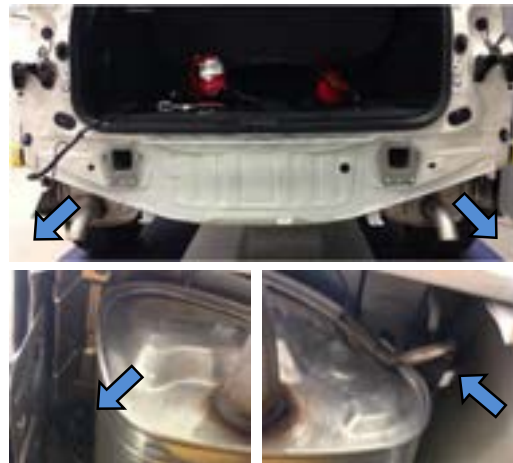

9. Offer the main Towbar assembly to the vehicle, via inserting the sidearms into the chassis rail.

Loosely secure each side with 3 x M12 Bolts and 3x M12 Flat Washers.

Tighten all Bolts to the following torque settings:

6 x M12 x 1.75P = 85Nm



**Cequent Customer Service**

Ph: 1800 812 017 Fax: 03 9898 3299

Email: [info@cequent.com.au](mailto:info@cequent.com.au)

Post: PO Box 4050, Dandenong South VIC 3175

# TRAILBOSS

Towbar Fitting Instructions  
To Suit **SUBARU LIBERTY 6<sup>TH</sup> GEN CLASS 4**  
Part Number **QTSB318L**  
Rating **1800/180 kg**

PLACE THESE INSTRUCTIONS IN THE VEHICLE'S GLOVEBOX AFTER INSTALLATION IS COMPLETED

10. Perform the bumper cut out as shown in the following image by using the bumper cut template found on the final page of these instructions.

Centre the template on the lower edge of the bumper and cut out.



11. At an appropriate position on the bumper, mark out and drill 2x  $\varnothing 5$ mm holes 69mm apart on bumper skin to support plug bracket.

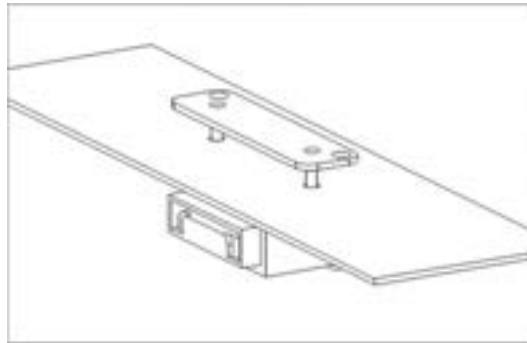

12. Re-fit all removed parts (steps 8-1) and secure all fasteners, ensuring there are no squeaks or rattles.

Place the fitting instructions in the glove box after fitment.

**Cequent Customer Service**

Ph: 1800 812 017 Fax: 03 9898 3299

Email: [info@cequent.com.au](mailto:info@cequent.com.au)

Post: PO Box 4050, Dandenong South VIC 3175





Towbar Fitting Instructions  
To Suit **SUBARU LIBERTY 6<sup>TH</sup> GEN CLASS 4**  
Part Number **QTSB318L**  
Rating **1800/180 kg**

PLACE THESE INSTRUCTIONS IN THE VEHICLE'S GLOVEBOX AFTER INSTALLATION IS COMPLETED

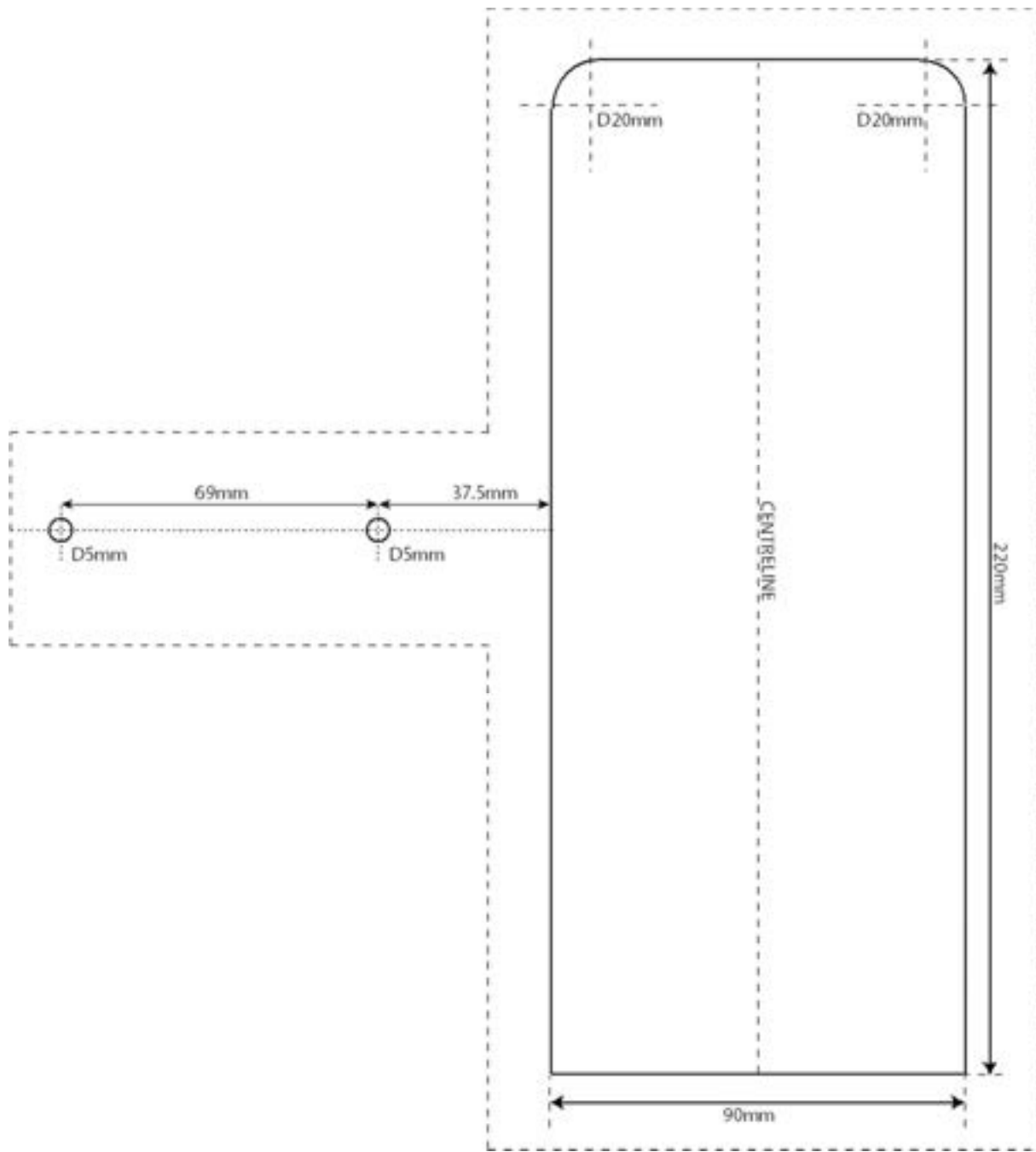

**Cequent Customer Service**  
Ph: 1800 812 017 Fax: 03 9898 3299  
Email: [info@cequent.com.au](mailto:info@cequent.com.au)  
Post: PO Box 4050, Dandenong South VIC 3175



Wiring Loom Fitting Instructions  
Liberty / Outback Wagon (2015 – Onwards)  
Part Number 100201-WL

### Wiring Loom Installation Instructions

Liberty / Outback Wagon (2015 – Onwards)  
Part No: 100201-WL

Tail Harness Length Required:  
Liberty/Outback Wagon (2015 – Onwards) – 1200 (WLT024)

Wiring Loom Installation Time: Approx. 25 Mins





Wiring Loom Fitting Instructions  
Liberty / Outback Wagon (2015 – Onwards)  
Part Number 100201-WL

1. In the luggage compartment, remove the rear parcel shelf.
2. Remove the rubber floor cover.
3. Remove the spare wheel cover and fold down the rear passenger LHS seat.
4. On the LHS of the luggage compartment trim, remove the fasteners from underneath all the trim latches and dislodge the LHS luggage compartment trim.
5. On the rear LHS of the vehicle exterior, next to the towbar center, drill a Ø30mm hole into the vehicle sheet metal. Ensure drilling is clear of objects on the other side.
6. File down any rough or sharp edges and apply rust inhibitor (not supplied).
7. Mount the trailer socket to the rear bumper via the tow bar mounting bracket (supplied with the towbar kit) using M4 fasteners (not supplied).
8. Route the tail harness (tail length: 1200mm) towards the LHS of the vehicle and up through the drilled grommet hole.
9. Connect the trailer patch (P/No: 100201-WL) to the vehicle break-out connector.
10. Connect the trailer patch tail connector to the tail harness connector.
11. At the vehicle exterior, ensure the tail harness grommet is seated correctly and secured into place using a cable tie (not supplied).
12. To enable the ISS (Intelligent Start Stop) cutout, splice the loose GREY/BLACK wire from the tail harness to the PIN 1 (GREY wire) of the connector.
13. On the tail harness splice the GREY wire back into any ground wire of the harness.  
**Note: Due to possible vehicle variations, always confirm vehicle harness wires using a multi-meter.**
14. Test the trailer wiring harness function using a light board or multi meter.
15. Secure all harnesses using cable ties (not supplied).
16. Re-fit all removed parts and secure all fasteners, ensuring there are no squeaks or rattles
17. Place the fitting instructions in the glove box after fitment.



# FITTING INSTRUCTIONS

## Silent Anti-Rattle Hitch Pin (PR0001)

• These fitting instructions are supplied to ensure understanding of how the HITCH PIN should be fitted and used correctly.

• Once installed, we recommend **ALL** instructions are kept and placed in the vehicle glove box.

**NOTE: Routine maintenance and inspection of the towbar & HITCH PIN is required. Regularly inspect for wear and check the tightness of the Hitch Pin. Follow instructions below to retighten the nut when necessary.**

**\*Do not tow with your vehicle if the R CLIP or the HITCH PIN is loose or missing. Replacement parts are available from your Pro Series Distributor.**

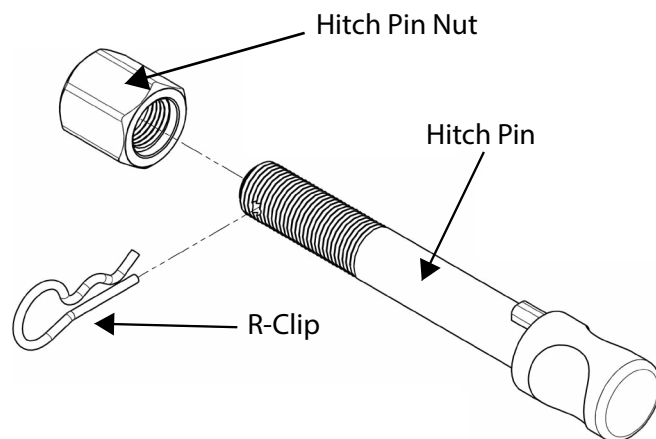

Fig 1. Silent Anti-Rattle Hitch Pin assembly

### STEP 1

Insert Trailer Ball Mount (TBM) into towbar HITCHBOX, aligning hole in TBM SHANK with hole in HITCHBOX (Fig 2).

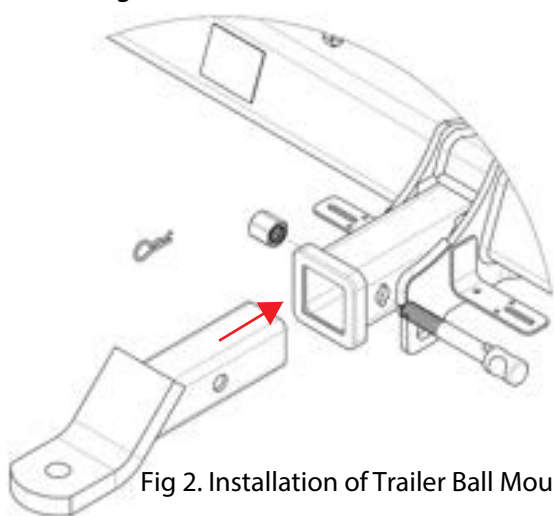

Fig 2. Installation of Trailer Ball Mount

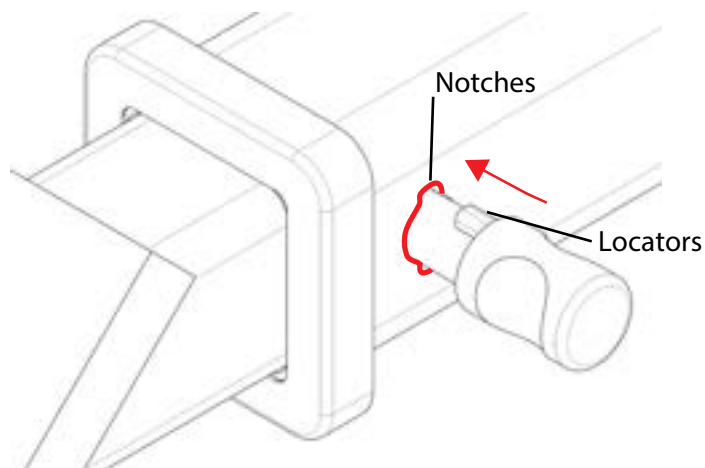

Fig 3. Silent Anti-Rattle Hitch Pin orientation

### STEP 2

Insert HITCH PIN through hole in HITCHBOX and hole in TBM SHANK; ensure the LOCATORS are inserted into the NOTCHES in the HITCHBOX (Fig. 3).

### STEP 3

Screw HITCH PIN NUT onto HITCH PIN ; tighten HITCH PIN NUT until finger tight, ensuring TBM is restrained from movement.

### STEP 4

Tighten HITCH PIN NUT by turning nut a further 1/8th of a turn in the clockwise direction using a 24mm spanner (Fig. 4).

### STEP 5

Install HITCH PIN R CLIP through the hole on the HITCH PIN (Fig. 1).

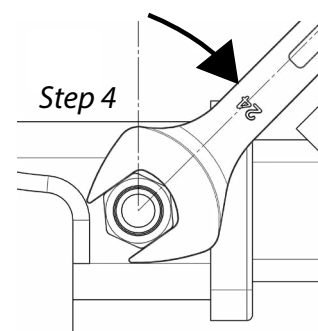

Fig 4. Tightening of Silent Anti-Rattle Hitch Pin Nut