

# TRAILBOSS

## Towbar Fitting Instructions To Suit **SUBARU FORESTER SERIES 5 CL4** Part Number **QTSB322L** Rating **1500/150 kg**

PLACE THESE INSTRUCTIONS IN THE VEHICLE'S GLOVEBOX AFTER INSTALLATION IS COMPLETED

### **WARNING:**

1. Do not, drill, cut, weld or otherwise modify the tow bar.
2. If you are using electric welding on a motor vehicle, **always** check that the vehicle is not equipped with electronic engine or instrument management equipment. Failure to do so could **destroy** any onboard computers. If in doubt, check with the vehicle's manufacturer.
3. The high tensile fasteners supplied with this product were used to achieve the specified rating. If replacement is required ensure that fasteners of the same rating & quality are used. Contact an authorised **Trailboss** dealer if further information is required.
4. If TBM is used in inverted position tow ball may make contact with rear tailgate when lowered, which could cause damage.

### **General:**

1. Ensure all hardware items have been included refer to assembly diagram.
2. It is recommended that the instructions are read through and completely understood before making any attempt to fit this product.
3. Be wary of any changes to vehicle designs or other accessories that may conflict with the installation of this product.
4. Before drilling ensure that the area is clear of fuel, electrical & other components.
5. All holes drilled into the body panels shall have all burrs & swarf removed then coated with a suitable rust preventative paint.
6. For vehicles that require the bumper to be cut. Ensure cut out area is in correct position on the vehicle prior to cutting the bumper.
7. The high tensile fasteners supplied with this product were used to achieve the specified rating. If replacement is required ensure that fasteners of the same rating & quality are used. Contact an authorized **Trailboss** dealer if further information is required.
8. Ensure that all hardware is fastened to torque list below check fasteners on regular basis.
9. Tow bar load rating sticker provided with this product shall be conspicuously located on inside rear end of the driver's door. **(See diagram below).**
10. Trailboss recommends that you check your tow ball to ensure that it complies with the Australian standards **AS 4177.2**.
11. **PLEASE NOTE:** It is advised to remove your LUG or TBM when not actually towing so as to produce a clear view of the vehicles registration plate if obscured, and to also provide maximum available departure angle

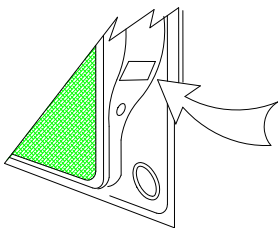

Place load rating sticker  
inside driver's door here

**FOR TRAILER TOWING PURPOSES ONLY**  
For towing capacity details please refer to vehicle owner's manual or to the manufacturer. Overloading can void your warranty.

#### RECOMMENDED ASSEMBLY TORQUE LISTING

| Diameter | Grade 8.8 Bolt |
|----------|----------------|
| M6       | 9.5 Nm         |
| M8       | 21.7 Nm        |
| M10      | 43.4 Nm        |
| M12      | 77.3Nm         |
| M14      | 146 Nm         |

### **Tow bar Maintenance and Care.**

Trailboss recommends that bolt torque's, as listed below, are routinely and regularly inspected and checked for correct tension. Replace any worn or defective parts.

We recommended to remove Tow Ball Mounts (TBM's, tongues or lugs) when not being used for any considerable length of time. So as to avoid injury, when not towing it is suggested that the tongue, Pull Pin and R-clip are removed then stored in a safe, clean and dry place, away from excessive moisture.

Hitch Pull Pins and spring "R" clips are regularly checked for proper installation. Replace any worn or defective parts.

**Cequent Customer Service**  
Ph: 1800 812 017 Fax: 03 9898 3299  
Email: info@cequent.com.au  
Post: PO Box 4050, Dandenong South VIC 3175

# TRAILBOSS

Towbar Fitting Instructions  
 To Suit **SUBARU FORESTER SERIES 5 CL4**  
 Part Number **QTSB322L**  
 Rating **1500/150 kg**

PLACE THESE INSTRUCTIONS IN THE VEHICLE'S GLOVEBOX AFTER INSTALLATION IS COMPLETED

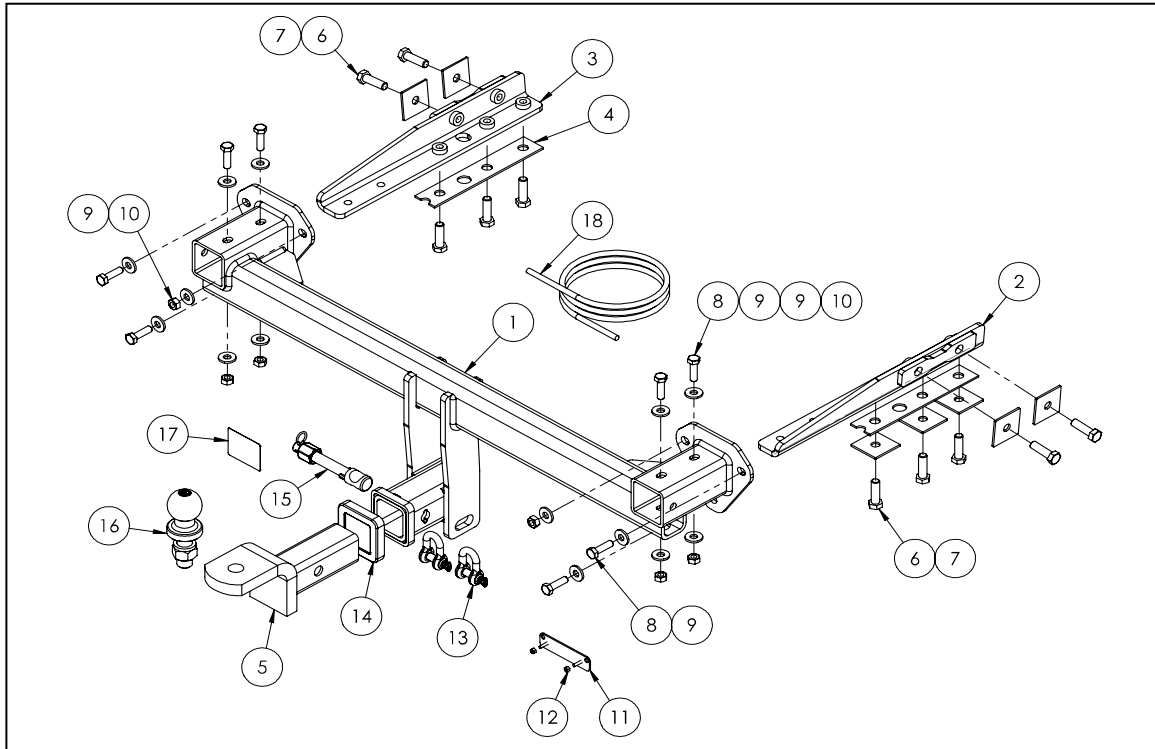

| ITEM | DESCRIPTION                       | QTY | ITEM | DESCRIPTION                      | QTY |
|------|-----------------------------------|-----|------|----------------------------------|-----|
| 1    | SUBARU FORESTER WELDED ASSEMBLY   | 1   | 10   | NUT HEX HD M10 X 1.25P G8        | 6   |
| 2    | SUBARU FORESTER SIDE ARM RHS      | 1   | 11   | VE PLUG BRACKET                  | 1   |
| 3    | SUBARU FORESTER SIDE ARM LHS      | 1   | 12   | NUT NYLON LOCK HEX HD M4X0.7P G8 | 2   |
| 4    | SIDE ARM SHIM PLATE               | 2   | 13   | 10mm "D" SHACKLE                 | 2   |
| 5    | TRAILER BALL MOUNT                | 1   | 14   | HITCH BOX COLLAR COVER           | 1   |
| 6    | BOLT M12 - 1.25 x 40mm GR 8.8 Z/P | 10  | 15   | SILENT HITCH PIN - SILVER        | 1   |
| 7    | LOOSE PLATE - COATED              | 10  | 16   | 50mm TOWBALL                     | 1   |
| 8    | SET SCREW HEX HD M10x35x1.25P     | 8   | 17   | ACRYLIC COMPLIANCE LABEL         | 1   |
| 9    | WASHER PLAIN M10 X 25 X 3         | 14  | 18   | WIRING LOOM                      | 1   |

**Cequent Customer Service**  
 Ph: 1800 812 017 Fax: 03 9898 3299  
 Email: [info@cequent.com.au](mailto:info@cequent.com.au)  
 Post: PO Box 4050, Dandenong South VIC 3175

# TRAILBOSS

Towbar Fitting Instructions  
To Suit **SUBARU FORESTER SERIES 5 CL4**  
Part Number **QTSB322L**  
Rating **1500/150 kg**

PLACE THESE INSTRUCTIONS IN THE VEHICLE'S GLOVEBOX AFTER INSTALLATION IS COMPLETED

1. Remove 2 x Phillips head screws from tail light cover. Carefully remove tail-light cover.

Repeat for opposite side.



2. Remove 2 x screws securing tail-light to vehicle.

Carefully pull tail-light rearward to dislodge and unclip any attached wiring. Set aside.

Repeat for opposite side.



3. On the side of the vehicle, remove 1 x scrivet from inside wheel arch.

Repeat for opposite side.



**Cequent Customer Service**

Ph: 1800 812 017 Fax: 03 9898 3299

Email: [info@cequent.com.au](mailto:info@cequent.com.au)

Post: PO Box 4050, Dandenong South VIC 3175

# TRAILBOSS

Towbar Fitting Instructions  
To Suit **SUBARU FORESTER SERIES 5 CL4**  
Part Number **QTSB322L**  
Rating **1500/150 kg**

PLACE THESE INSTRUCTIONS IN THE VEHICLE'S GLOVEBOX AFTER INSTALLATION IS COMPLETED

4. Remove all scrivets from underside of bumper.

Carefully peel back bumper from corners and remove. Ensure all attached wiring is unclipped.

Set bumper aside.



5. Loosen impact beam by removing 2 x hex head screws and 1 x hex head nut per side.

Discard impact beam and fasteners.



6. Remove exhaust from 2 x rubber hangers and lower. Ensure exhaust is supported.



**Cequent Customer Service**

Ph: 1800 812 017 Fax: 03 9898 3299

Email: [info@cequent.com.au](mailto:info@cequent.com.au)

Post: PO Box 4050, Dandenong South VIC 3175

# TRAILBOSS

Towbar Fitting Instructions  
To Suit **SUBARU FORESTER SERIES 5 CL4**  
Part Number **QTSB322L**  
Rating **1500/150 kg**

PLACE THESE INSTRUCTIONS IN THE VEHICLE'S GLOVEBOX AFTER INSTALLATION IS COMPLETED

7. Remove heat shield above exhaust by removing 4 x hex head screw.

Set aside heat shield and fasteners.



8. Remove 5 x rubber plugs, 3 x bottom and 2 x side, from chassis rail.



9. Insert the supplied 3mm shim plates into chassis rail. Ensure the shim holes align with the horizontal chassis holes.

Repeat for opposite side.



**Cequent Customer Service**

Ph: 1800 812 017 Fax: 03 9898 3299

Email: [info@cequent.com.au](mailto:info@cequent.com.au)

Post: PO Box 4050, Dandenong South VIC 3175

# TRAILBOSS

Towbar Fitting Instructions  
To Suit **SUBARU FORESTER SERIES 5 CL4**  
Part Number **QTSB322L**  
Rating **1500/150 kg**

PLACE THESE INSTRUCTIONS IN THE VEHICLE'S GLOVEBOX AFTER INSTALLATION IS COMPLETED

10. Insert side arm into chassis rail and loosely secure with 5 x M12 x 40mm bolts, 2 x side and 3 x bottom, complete with 1 x square plate per bolt.

Repeat for opposite side.

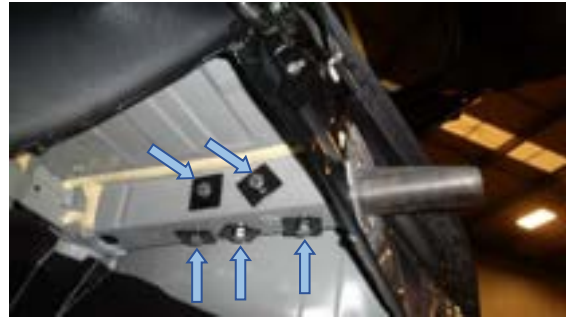

11. With two people, lifted welded centre sections over side arm and onto 2 x studs on rear panel.

Loosely secure to rear panel with 2 x M10 x 35mm bolts and 1 x M10 nut complete with 1 x washer per nut/bolt.

Repeat for opposite side.



12. Secure side arms to welded centre section with 2 x M10 x 35mm bolts complete with 2 x washers and 1 x M10 nut per bolt as shown.

Repeat for opposite side.

**Tighten all fasteners to the torques listed below:**

M10 x 35mm: 48 N.m

M12 x 40mm: 89 N.m



**Cequent Customer Service**

Ph: 1800 812 017 Fax: 03 9898 3299

Email: [info@cequent.com.au](mailto:info@cequent.com.au)

Post: PO Box 4050, Dandenong South VIC 3175

Towbar Fitting Instructions  
To Suit **SUBARU FORESTER SERIES 5 CL4**  
Part Number **QTSB322L**  
Rating **1500/150 kg**

PLACE THESE INSTRUCTIONS IN THE VEHICLE'S GLOVEBOX AFTER INSTALLATION IS COMPLETED

13. Identify the centre of the bumper. Measure, mark and cut a 140mm high x 100mm wide rectangle as measured from the inside bottom edge of the bumper.

Clean edges of bumper after cut to ensure there are no burrs.

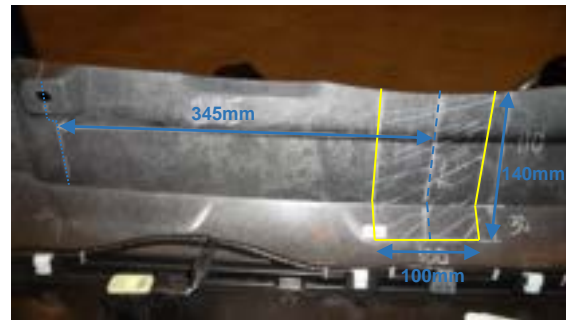

14. Mark a 125mm wide rectangle on the heat shield (removed in Step 7) as measured 135mm in from right hand edge as illustrated. Cut from the bottom edge shown up to the major fold line.

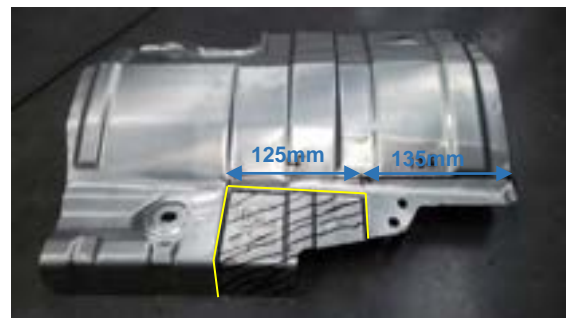

15. Mark out and drill 2 x  $\varnothing 5$ mm holes 69mm apart on bumper skin to support plug bracket.

16. Re-install all components following steps 1-7 in reverse.

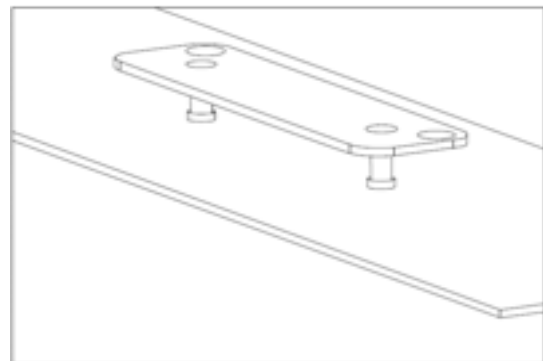

**Cequent Customer Service**  
Ph: 1800 812 017 Fax: 03 9898 3299  
Email: [info@cequent.com.au](mailto:info@cequent.com.au)  
Post: PO Box 4050, Dandenong South VIC 3175



Wiring Loom Fitting Instructions  
To suit SUBARU FORESTER SERIES 5 CL4  
Part Number 102096-WL

Wiring Loom Installation Instructions

SUBARU FORESTER MY19

Part No: 102096-WL

ECU: 04826

Tail Length Part No: 04943

RPA Disable: Instant Stop Start built into harness

Electric brake input location: Near Breakout connector

Wiring Loom Installation Time: Approx. 30 Mins





Wiring Loom Fitting Instructions  
To suit SUBARU FORESTER SERIES 5 CL4  
Part Number 102096-WL

1. Disconnect negative battery terminal (1).
2. In the boot, fold the rear seats down (1).
3. Remove the floor carpet and the spare wheel cover (2).
4. Remove LHS foam coverings (1) by removing the two black push clips (2).
5. Remove the spare wheel (3).
6. Remove the boot scuff plate (4) by pulling in an upwards direction.
7. Remove the 10mm bolt (1) holding the LHS trim in place.
8. Dislodge the LHS trim (2).
9. Locate the vehicle trailer pre wire female connector.
10. Carefully remove tape (1) securing the vehicle trailer wiring female connector and plug into the patch harness (102096-WL) mating male connector.
11. Using an alcohol wipe, clean the LHS inner sheet metal area and the underside of the ECU (04826)(1).
12. Connect the trailer patch 12-way connector (2) to the ECU (1).
13. Apply double sided tape (3) to the ECU (1) and secure it to the vehicle sheet metal.

**Note: Mount the ECU, ensuring the connector is orientated downwards.**

14. Drill a Ø30mm grommet hole in a suitable location to enable the tail harness to be routed from the towbar to the ECU via the chassis rail access.
15. With the rear bumper removed, secure the tail harness (04943) to towbar.
16. Route the tail harness up through chassis rail and previously drilled grommet hole.
17. Seat grommet in 30mm hole and route to trailer harness blue connector on wiring loom.

**Note: Keep harness routing clear of all sharp edges, moving parts and places of extreme heat.**

**Note: Ensure grommet is seated correctly and makes a good seal.**

18. Connect the tail harness 8-way connector (1) to the trailer patch mating 8-way connector (2).
19. Cut-off, crimp the tail harness GREY and GREY/BLACK wires (3) to the trailer patch matching WHITE and GREY/BLACK wires (4).



Wiring Loom Fitting Instructions  
To suit SUBARU FORESTER SERIES 5 CL4  
Part Number 102096-WL

20. Secure all harness using cable ties.
21. Test the trailer patch function using a light board or multi-meter.
22. Secure all harness using cable ties (not supplied)
23. Re-fit all removed parts and secure all fasteners, ensuring there are no squeaks or rattles.
24. Place the fitting instructions in the glove box after fitment.



# FITTING INSTRUCTIONS

## Silent Anti-Rattle Hitch Pin (PR0001)

• These fitting instructions are supplied to ensure understanding of how the HITCH PIN should be fitted and used correctly.

• Once installed, we recommend **ALL** instructions are kept and placed in the vehicle glove box.

**NOTE: Routine maintenance and inspection of the towbar & HITCH PIN is required. Regularly inspect for wear and check the tightness of the Hitch Pin. Follow instructions below to retighten the nut when necessary.**

**\*Do not tow with your vehicle if the R CLIP or the HITCH PIN is loose or missing. Replacement parts are available from your Pro Series Distributor.**

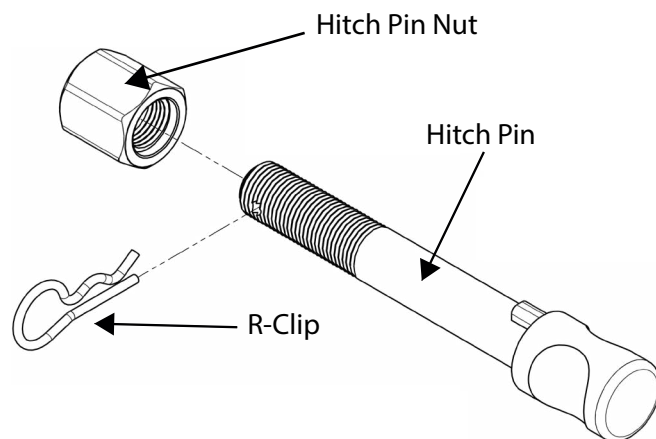

Fig 1. Silent Anti-Rattle Hitch Pin assembly

### STEP 1

Insert Trailer Ball Mount (TBM) into towbar HITCHBOX, aligning hole in TBM SHANK with hole in HITCHBOX (Fig 2).

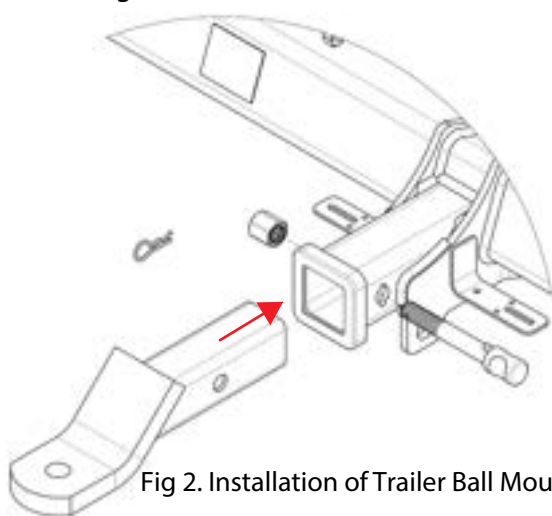

Fig 2. Installation of Trailer Ball Mount

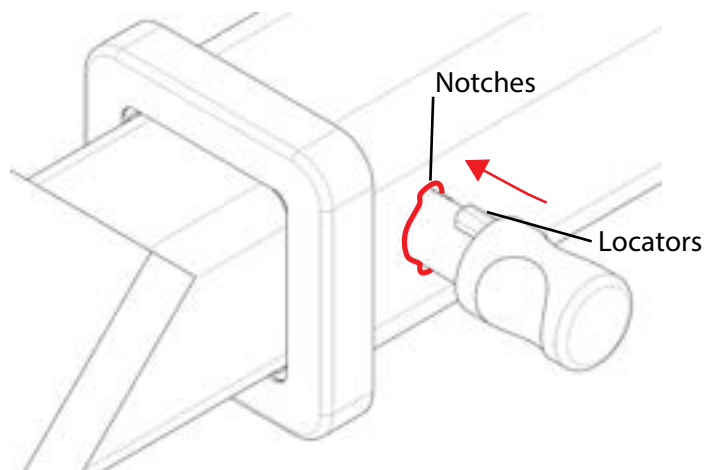

Fig 3. Silent Anti-Rattle Hitch Pin orientation

### STEP 2

Insert HITCH PIN through hole in HITCHBOX and hole in TBM SHANK; ensure the LOCATORS are inserted into the NOTCHES in the HITCHBOX (Fig. 3).

### STEP 3

Screw HITCH PIN NUT onto HITCH PIN; tighten HITCH PIN NUT until finger tight, ensuring TBM is restrained from movement.

### STEP 4

Tighten HITCH PIN NUT by turning nut a further 1/8th of a turn in the clockwise direction using a 24mm spanner (Fig. 4).

### STEP 5

Install HITCH PIN R CLIP through the hole on the HITCH PIN (Fig. 1).

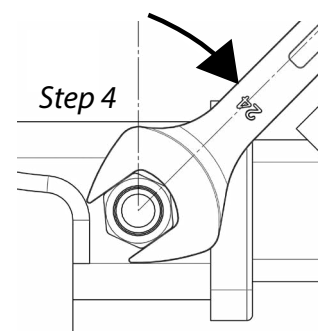

Fig 4. Tightening of Silent Anti-Rattle Hitch Pin Nut