

TRAILBOSS

Towbar Fitting Instructions To Suit **SUBARU XV G5X CL4** Part Number **QTSB323L** Rating **1400/140 kg**

PLACE THESE INSTRUCTIONS IN THE VEHICLE'S GLOVEBOX AFTER INSTALLATION IS COMPLETED

WARNING:

1. Do not, drill, cut, weld or otherwise modify the tow bar.
2. If you are using electric welding on a motor vehicle, **always** check that the vehicle is not equipped with electronic engine or instrument management equipment. Failure to do so could **destroy** any onboard computers. If in doubt, check with the vehicle's manufacturer.
3. The high tensile fasteners supplied with this product were used to achieve the specified rating. If replacement is required ensure that fasteners of the same rating & quality are used. Contact an authorised **Trailboss** dealer if further information is required.
4. If TBM is used in inverted position tow ball may make contact with rear tailgate when lowered, which could cause damage.

General:

1. Ensure all hardware items have been included refer to assembly diagram.
2. It is recommended that the instructions are read through and completely understood before making any attempt to fit this product.
3. Be wary of any changes to vehicle designs or other accessories that may conflict with the installation of this product.
4. Before drilling ensure that the area is clear of fuel, electrical & other components.
5. All holes drilled into the body panels shall have all burrs & swarf removed then coated with a suitable rust preventative paint.
6. For vehicles that require the bumper to be cut. Ensure cut out area is in correct position on the vehicle prior to cutting the bumper.
7. The high tensile fasteners supplied with this product were used to achieve the specified rating. If replacement is required ensure that fasteners of the same rating & quality are used. Contact an authorized **Trailboss** dealer if further information is required.
8. Ensure that all hardware is fastened to torque list below check fasteners on regular basis.
9. Tow bar load rating sticker provided with this product shall be conspicuously located on inside rear end of the driver's door. **(See diagram below)**.
10. Trailboss recommends that you check your tow ball to ensure that it complies with the Australian standards **AS 4177.2**.
11. **PLEASE NOTE:** It is advised to remove your LUG or TBM when not actually towing so as to produce a clear view of the vehicles registration plate if obscured, and to also provide maximum available departure angle

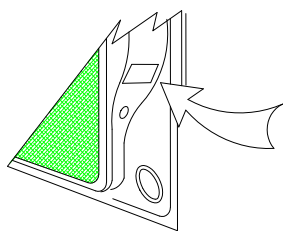

Place load rating sticker
inside driver's door here

FOR TRAILER TOWING PURPOSES ONLY
For towing capacity details please refer to vehicle owner's manual or to the manufacturer. Overloading can void your warranties.

RECOMMENDED ASSEMBLY TORQUE LISTING

Diameter	Grade 8.8 Bolt
M6	9.5 Nm
M8	21.7 Nm
M10	43.4 Nm
M12	77.3Nm
M14	146 Nm
M16	189.8 Nm

Tow bar Maintenance and Care.

Trailboss recommends that bolt torque's, as listed below, are routinely and regularly inspected and checked for correct tension. Replace any worn or defective parts.

We recommended to remove Tow Ball Mounts (TBM's, tongues or lugs) when not being used for any considerable length of time.

So as to avoid injury, when not towing it is suggested that the tongue, Pull Pin and R-clip are removed then stored in a safe, clean and dry place, away from excessive moisture.

Hitch Pull Pins and spring "R" clips are regularly checked for proper installation. Replace any worn or defective parts.

Cequent Customer Service
Ph: 1800 812 017 Fax: 03 9898 3299
Email: info@cequent.com.au
Post: PO Box 4050, Dandenong South VIC 3175

TRAILBOSS

Towbar Fitting Instructions
 To Suit **SUBARU XV G5X CL4**
 Part Number **QTSB323L**
 Rating **1400/140 kg**

PLACE THESE INSTRUCTIONS IN THE VEHICLE'S GLOVEBOX AFTER INSTALLATION IS COMPLETED

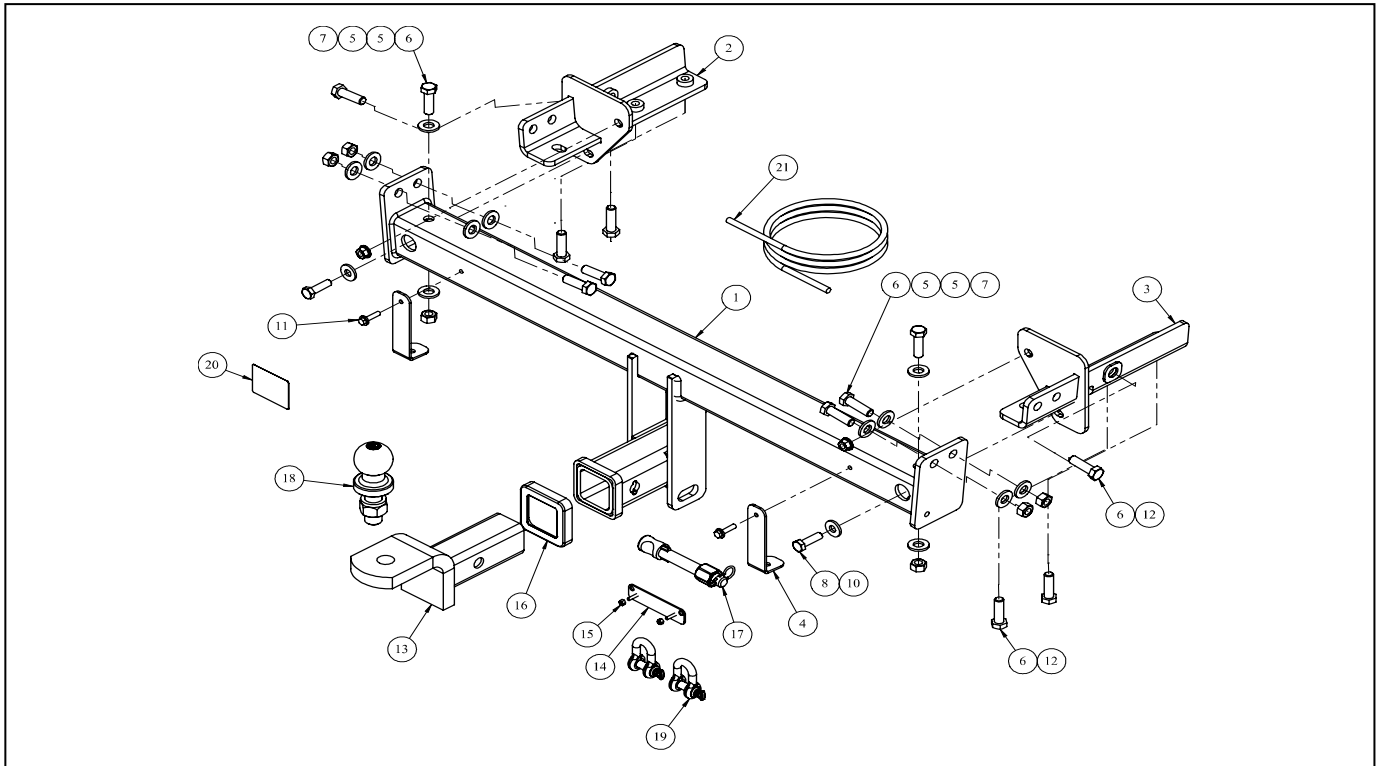

ITEM	DESCRIPTION	QTY
1	WELDED ASSEMBLY	1
2	SIDE ARM LHS	1
3	SIDE ARM RHS	1
4	BUMPER TAB	2
5	WASHER PLAIN1/2x1-1/8x16G	12
6	BOLT M12-1.25x40MM GR 8.8 Z/P	12
7	NUT HEX HD M12x1.25P G8	6
8	SET SCREW HEX HD M10x35x1.25P	2
9	FLANGE NUT M10x1.25P	2
10	WASHER FT M10x25.4x3	2
11	TEK SCREW 14-20 HEX HD 22MM	2

ITEM	DESCRIPTION	QTY
12	LOOSE PLATE-COATED	6
13	TRAILER BALL MOUNT	1
14	VE PLUG BRACKET	1
15	NUT NYLON LOCK HEX HD M4x0.7P G8	2
16	HITCH BOX COLLAR COVER	1
17	SILENT HITCH PIN - SILVER	1
18	50mm TOWBALL	1
19	10mm "D" SHACKLE	2
20	ACRYLIC COMPLIANCE LABEL	1
21	WIRING LOOM	1

Cequent Customer Service
 Ph: 1800 812 017 Fax: 03 9898 3299
 Email: info@cequent.com.au
 Post: PO Box 4050, Dandenong South VIC 3175

TRAILBOSS

Towbar Fitting Instructions
To Suit **SUBARU XV G5X CL4**
Part Number **QTSB323L**
Rating **1400/140 kg**

PLACE THESE INSTRUCTIONS IN THE VEHICLE'S GLOVEBOX AFTER INSTALLATION IS COMPLETED

1. Remove 8 x scrivets from underside of bumper



2. Remove 1 x scrivet inside wheel arch.
Repeat for opposite side



3. Pop out 2 x plastic covers on tail lights and remove the exposed 2 x hex head screws. Remove taillights by firmly pulling rearwards of vehicle and disconnect wiring from taillight. Set taillight safely aside.

Repeat for opposite side.



Cequent Customer Service

Ph: 1800 812 017 Fax: 03 9898 3299

Email: info@cequent.com.au

Post: PO Box 4050, Dandenong South VIC 3175

TRAILBOSS

Towbar Fitting Instructions
To Suit **SUBARU XV G5X CL4**
Part Number **QTSB323L**
Rating **1400/140 kg**

PLACE THESE INSTRUCTIONS IN THE VEHICLE'S GLOVEBOX AFTER INSTALLATION IS COMPLETED

4. Remove bumper by unclipping both corners near wheel arch. Carefully peel back from corners.

Once fully unclipped disconnect any wiring that may be connected and set bumper safely aside.

5. Remove impact beam via 6 x hex head bolts.

Discard impact beam.



6. Pop out 3 x rubber hole covers in chassis rail.

Repeat for opposite side.

Cequent Customer Service
Ph: 1800 812 017 Fax: 03 9898 3299
Email: info@cequent.com.au
Post: PO Box 4050, Dandenong South VIC 3175

TRAILBOSS

Towbar Fitting Instructions
To Suit **SUBARU XV G5X CL4**
Part Number **QTSB323L**
Rating **1400/140 kg**

PLACE THESE INSTRUCTIONS IN THE VEHICLE'S GLOVEBOX AFTER INSTALLATION IS COMPLETED

7. Remove bumper tabs on back panel via 2 x scrivenets.



8. Insert side arm into chassis rail and loosely secure with 3 x M12 bolts on chassis rail complete with 1 x M12 washer per bolt.

Loosely secure side arms to rear panel via 1 x M10 bolt and 1 x M10 nut complete with 1 x M10 washer per bolt/nut.

Repeat for opposite side.

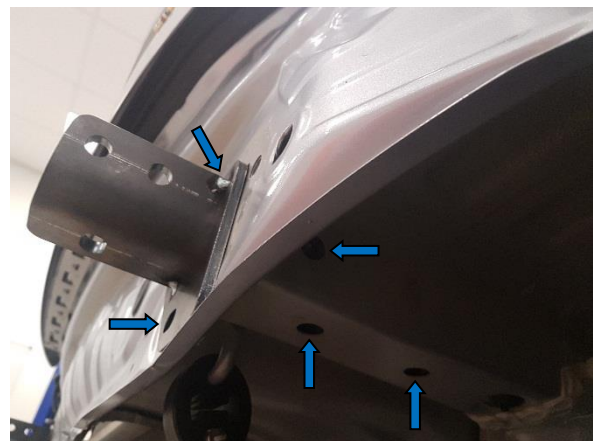

9. Secure cross beam to side arms via 3 x M12 bolts complete with 2 x M12 washer and 1 x M12 nut per bolt.

Repeat for opposite side.

Tighten all fasteners to the torques listed below:

M12- 89N.m

M10- 48N.m

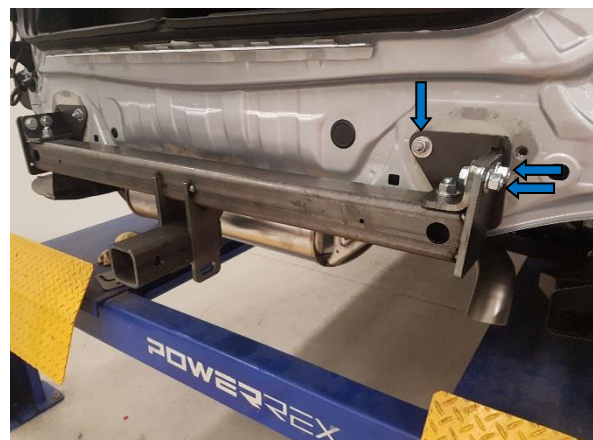

Cequent Customer Service

Ph: 1800 812 017 Fax: 03 9898 3299

Email: info@cequent.com.au

Post: PO Box 4050, Dandenong South VIC 3175

TRAILBOSS

Towbar Fitting Instructions
To Suit **SUBARU XV G5X CL4**
Part Number **QTSB323L**
Rating **1400/140 kg**

PLACE THESE INSTRUCTIONS IN THE VEHICLE'S GLOVEBOX AFTER INSTALLATION IS COMPLETED

10. Attached bumper tabs facin tow bar via 2 x tek screws and tighten.

11. Identify the centre of the bumper and cut out a 115mm tall x 90mm wide rectangle, starting from the bottom edge of the bumper, and following the outer edge of the bumper.

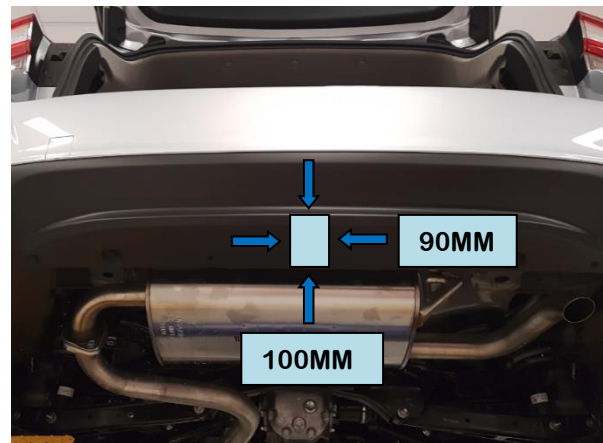

12. Mark out and drill 2 x Ø5mm holes 69mm apart on bumper skin to support plug bracket. Feed bracket through drilled holes prior to reinstalling bumper.

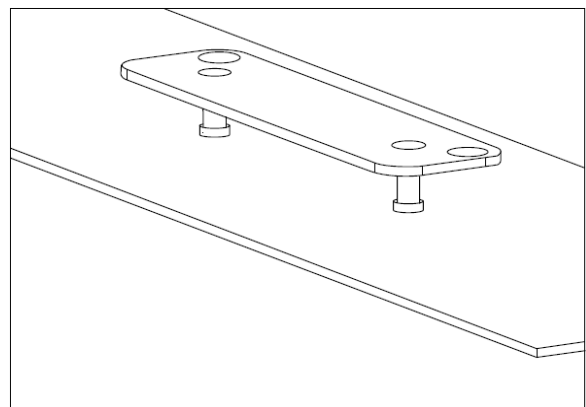

Cequent Customer Service
Ph: 1800 812 017 Fax: 03 9898 3299
Email: info@cequent.com.au
Post: PO Box 4050, Dandenong South VIC 3175



Towbar Fitting Instructions
To Suit **SUBARU XV G5X CL4**
Part Number **QTSB323L**
Rating **1400/140 kg**

PLACE THESE INSTRUCTIONS IN THE VEHICLE'S GLOVEBOX AFTER INSTALLATION IS COMPLETED

13. Refit removed parts and secure all fasteners, ensuring there are no squeaks or rattles.
14. Align holes below bumper with bumper tabs on towbar. Fix bumper to tabs via 2 x scrivenets.
15. Place the instructions in the glove box after fitment.

Cequent Customer Service
Ph: 1800 812 017 Fax: 03 9898 3299
Email: info@cequent.com.au
Post: PO Box 4050, Dandenong South VIC 3175



Wiring Loom Fitting Instructions
To Suit SUBARU XV G5X CL4
Part Number 101543-WL

Wiring Loom Installation Instructions

SUBARU XV G5X CL4

Part No: 101543-WL

Trailer Wiring Harness: 101543-WL

Tail Harness Length Required: 1200mm

Tail Length Part No: WLT024

Electric Brake Wire Location: Near blue connector

Wiring Loom Installation Time: Approx 30 Mins



Wiring Loom Fitting Instructions
To Suit SUBARU XV G5X CL4
Part Number 101543-WL

1. In the boot, fold down the rear seats.
2. Remove the rear sunshade.
3. Remove the luggage compartment floor carpet.
4. Remove all foam trim over the spare wheel.
5. Remove the LHS & RHS luggage compartment foam trim by removing the two trim clips holding it in place.
6. Remove the spare wheel.
7. Remove the rear boot scuff plate by removing the two trim clips and lifting firmly in an upwards direction.
8. On the LHS rear quarter trim, locate the two phillips head screws and remove.
9. Using a 10mm socket, remove the bolt securing the luggage hook to the chassis.
10. Dislodge the LHS trim to gain access to the pre-wire connector.
11. Connect the tail harness (tail length 1200mm) 8-way connector to the trailer patch harness (101543-WL) mating 8-way connector.
12. Cut-off, crimp the tail harness GREY and GREY/BLACK wires to the trailer patch matching WHITE and GREY/BLACK wires.
13. Secure all harness using cable ties.
14. With the rear bumper removed, secure tail harness to towbar.
15. Below the LHS tail light, locate the 30mm blanking grommet and remove.
16. Route tail and patch harness up through chassis rail and previously removed blanking grommet.
17. Seat grommet in 30mm blanking hole and route towards vehicle pre-wire connector.
18. Remove the coloured tape surrounding the pre-wire connector and connect to patch harness.
19. Test the trailer patch function using a light board or multi-meter.
20. Secure all harness using cable ties (not supplied).
21. Re-fit all removed parts and secure all fasteners, ensuring there are no squeaks or rattles.
22. Place the fitting instructions in the glove box after fitment.



FITTING INSTRUCTIONS

Silent Anti-Rattle Hitch Pin (PR0001)

• These fitting instructions are supplied to ensure understanding of how the HITCH PIN should be fitted and used correctly.

• Once installed, we recommend **ALL** instructions are kept and placed in the vehicle glove box.

NOTE: Routine maintenance and inspection of the towbar & HITCH PIN is required. Regularly inspect for wear and check the tightness of the Hitch Pin. Follow instructions below to retighten the nut when necessary.

***Do not tow with your vehicle if the R CLIP or the HITCH PIN is loose or missing. Replacement parts are available from your Pro Series Distributor.**

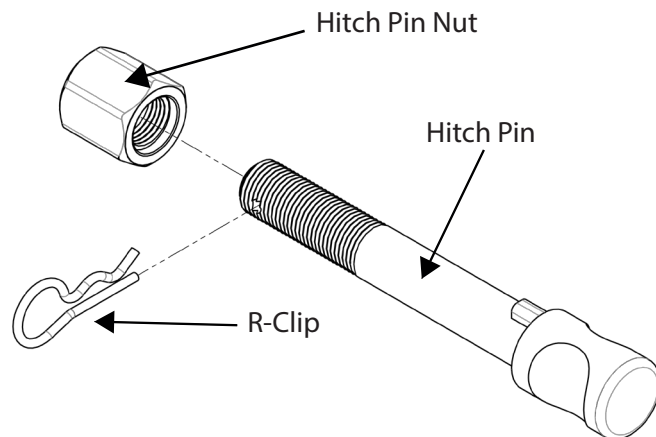

Fig 1. Silent Anti-Rattle Hitch Pin assembly

STEP 1

Insert Trailer Ball Mount (TBM) into towbar HITCHBOX, aligning hole in TBM SHANK with hole in HITCHBOX (Fig 2).

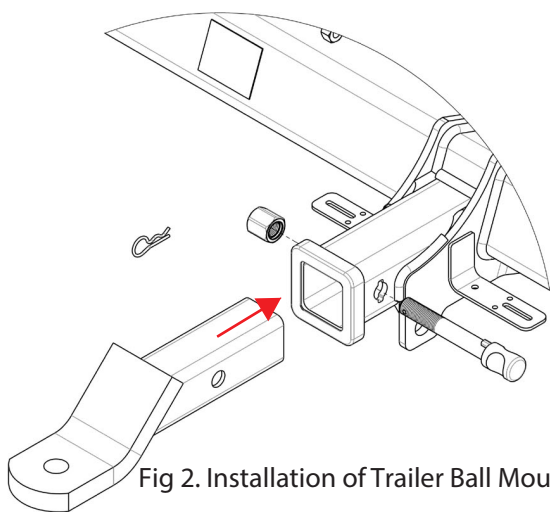

Fig 2. Installation of Trailer Ball Mount

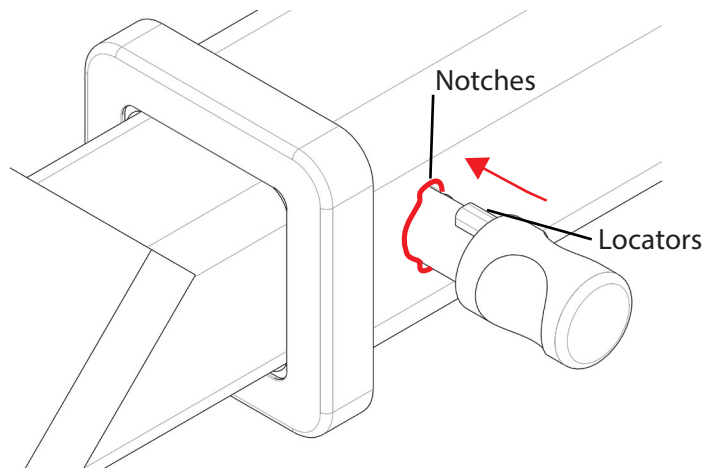

Fig 3. Silent Anti-Rattle Hitch Pin orientation

STEP 2

Insert HITCH PIN through hole in HITCHBOX and hole in TBM SHANK; ensure the LOCATORS are inserted into the NOTCHES in the HITCHBOX (Fig. 3).

STEP 3

Screw HITCH PIN NUT onto HITCH PIN ; tighten HITCH PIN NUT until finger tight, ensuring TBM is restrained from movement.

STEP 4

Tighten HITCH PIN NUT by turning nut a further 1/8th of a turn in the clockwise direction using a 24mm spanner (Fig. 4).

STEP 5

Install HITCH PIN R CLIP through the hole on the HITCH PIN (Fig. 1).

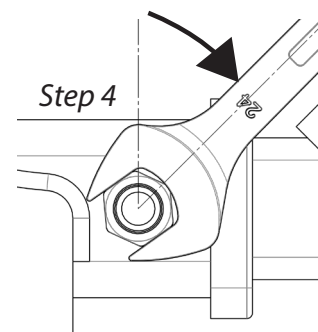

Fig 4. Tightening of Silent Anti-Rattle Hitch Pin Nut