

**PRODUCT DETAILS:**

---

|                                      |          |                                  |      |    |
|--------------------------------------|----------|----------------------------------|------|----|
| <b>Part Number:</b>                  | QTSB325L | <b>Maximum Towing Braked:</b>    | 2000 | kg |
| <b>ECU Number:</b>                   | 04826    | <b>Maximum Towing Unbraked:</b>  | 750  | kg |
| <b>Tail Harness Length Required:</b> | 1200 mm  | <b>Maximum Static Ball Load:</b> | 200  | kg |
| <b>TBM/Lug Part Number:</b>          | 21201    |                                  |      |    |

---

**FITTING DETAILS:**

---

|                                  |           |                           |    |
|----------------------------------|-----------|---------------------------|----|
| <b>Towbar Installation Time:</b> | 90 Mins.  | <b>RPA Disable/Other:</b> | NO |
| <b>Total Installation Time:</b>  | 115 Mins. |                           |    |
| <b>Bumper Cut Required:</b>      | Yes       |                           |    |

---

**Note:**

- RPA and RAB is disabled via infotainment.  
(To disable you must press and hold the RPA and RAB buttons.)
- Instant Stop Start built into the harness must use open circuit tail 04943.

### TRAILBOSS RECOMMENDS THAT INSTRUCTIONS ARE READ AND UNDERSTOOD COMPLETELY PRIOR TO FITMENT.

#### BEFORE YOU START:

Check all hardware items have been included refer to assembly diagram.  
Please ensure this towbar is only fitted to vehicle models as per Trailboss application guide.

#### Bumper Cuts

Vehicle and bumper variations can and do occur during vehicle manufacture after initial towbar design. Fitment of towbar to vehicle and accuracy of bumper cut must be assessed prior to any bumper modifications made. Incorrect bumper cuts are not covered under Trailboss warranty.

**NOTE: Bumper cuts need to be approached with care, refer to notes below.**

- Bumper centreline – where the centreline of the bumper needs to be determined, the installer must assess centre point by measurement of bumper width or determining two symmetrical reference points to give centreline.
- Bumper edge – To assist with accurate bumper cut measurement, reference to the start of the bumper edge is now being commonly used.
  - Measure from bottom edge along bumper and around corner to the 70 mm point (Figure 1).
  - Do not measure from visible bumper front of corner, upwards (Figure 2).

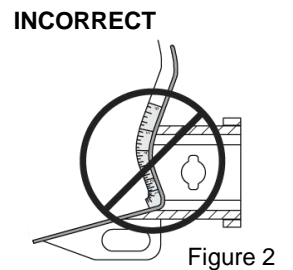
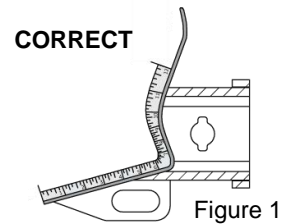

#### Drilling

- For any required drilling during installation, ensure that the area is clear of fuel, electrical & other components that may be damaged.
- All holes drilled into metal body panels shall have all burrs & swarf removed then coated with a suitable rust preventative paint.

#### Bolts/Fasteners

- Ensure that all hardware is fastened to correct torque as specified in this fitting instruction.
- All fasteners supplied with this product are used to achieve a specified clamp loading. If replacement is required ensure that fasteners of the same grade and class are used.

**NOTE: Achieving correct torque is critical to proper installation and responsibility of the installer. Towbar failures attributed to tension issues from over tightening or under tightening are not covered by Trailboss warranty.**

#### Product Labels

- a. Towbar load rating sticker provided with this product shall be conspicuously located on inside rear end of the driver's door.

#### WARNING:

**Do not, drill, cut, weld or otherwise modify the towbar.**

**FOR TOWING PURPOSES ONLY - This towbar is designed and tested by Trailboss to adhere to ADR 62/02 which provides only for the expected load demands of towing.**

### **i** TOWBAR ASSEMBLY DIAGRAM

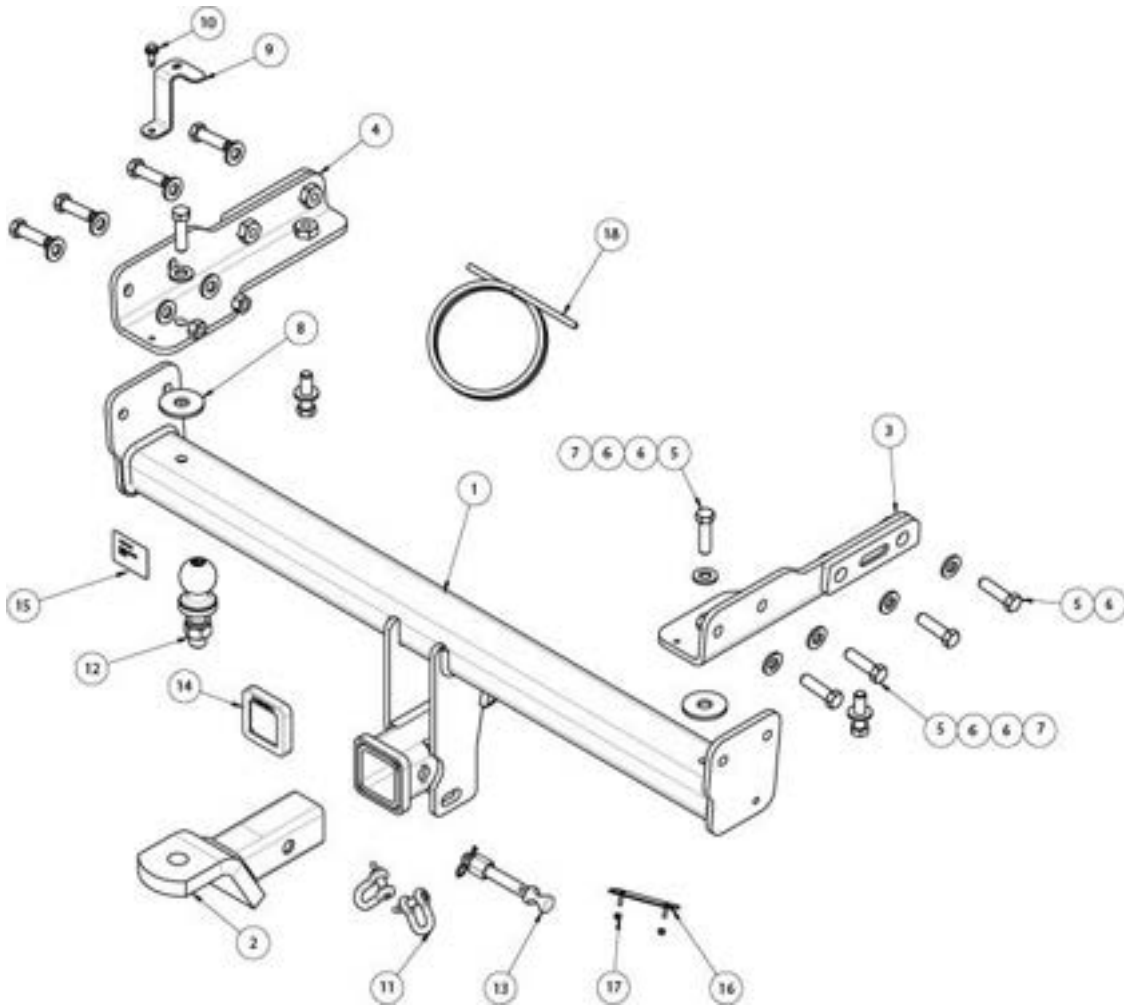

| ITEM | DESCRIPTION                | QTY |
|------|----------------------------|-----|
| 1    | SUBARU OUTBACK WELDED ASSY | 1   |
| 2    | TRAILER BALL MOUNT         | 1   |
| 3    | SIDE ARM RHS ASSY          | 1   |
| 4    | SIDE ARM LHS ASSY          | 1   |
| 5    | BOLT HEX HD M12x45x1.75P   | 12  |
| 6    | WASHER PLAIN 1/2"          | 18  |
| 7    | NUT HEX HD M12x1.75P       | 6   |
| 8    | WASHER PLAIN M16x50x4      | 2   |
| 9    | SENSOR BRACKET             | 1   |

| ITEM | DESCRIPTION                 | QTY |
|------|-----------------------------|-----|
| 10   | TEK SCREW 14-20 HEX HD 22mm | 1   |
| 11   | "D" SHACKLE 10mm            | 2   |
| 12   | TOWBALL 50mm                | 1   |
| 13   | SMART PIN SILVER            | 1   |
| 14   | HITCH BOX COLLAR COVER      | 1   |
| 15   | COMPLIANCE LABEL            | 1   |
| 16   | PLUG BRACKET                | 1   |
| 17   | NUT NYLOC HEX HD M4x0.7P    | 2   |
| 18   | WIRE LOOM                   | 1   |

- 
1. Disconnect negative battery terminal (1).

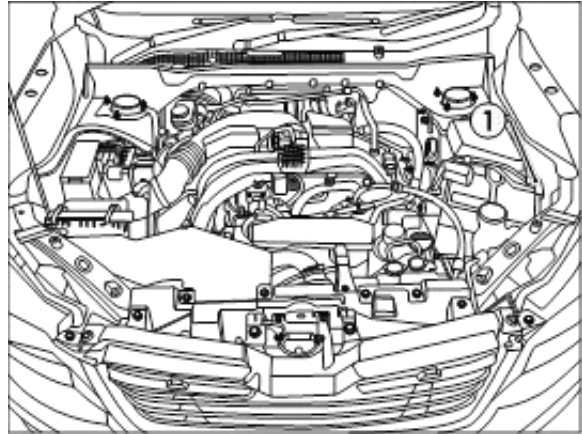

- 
2. Open the rear tailgate.  
Remove 2x scrivet clips.  
Remove the plastic cover.

Repeat for the other side

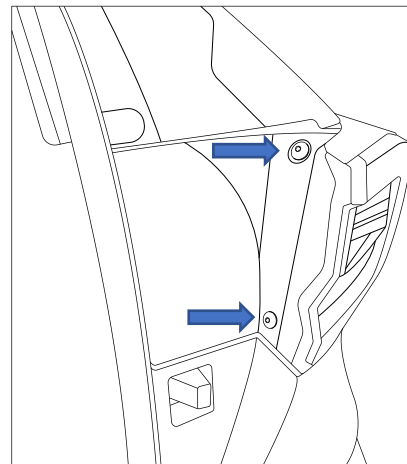

- 
3. Remove 2x screws.  
Pull the taillight rear ward and disconnect the wire.

Repeat for the other side.

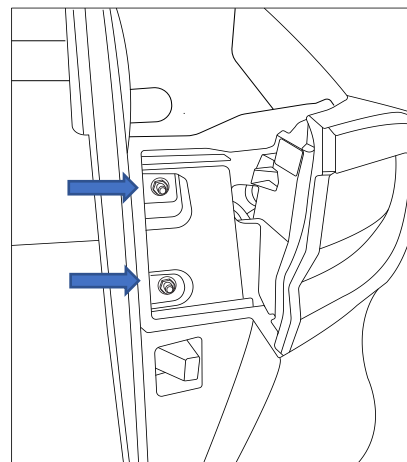

- 
4. Remove 2x scrivet clips and 3x screws.

Repeat for the other side.

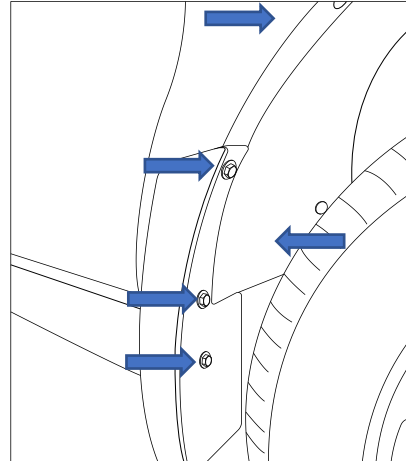

- 
5. Remove 3x scrivet clips.  
Remove 2x scrivet clips on bottom edge.  
Remove mudflap assembly.  
Remove final scrivet from bumper edge after removal of mudflap.

Repeat for the other side.

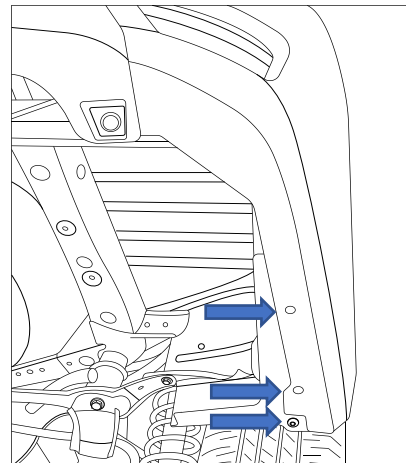

- 
6. Remove 3x scrivets clips under the bumper.

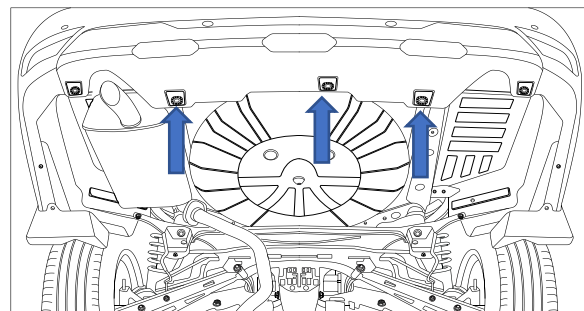

- 
7. Remove 2x bolts from the exhaust muffler.  
Slide 2x muffler isolators off the hook mounts.  
Remove the muffler.

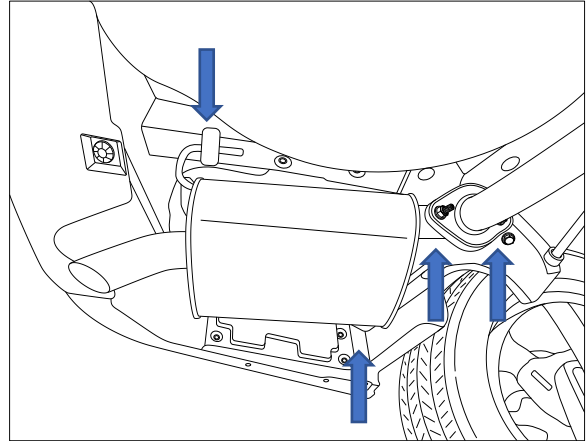

- 
8. Remove 4x screws from the heat shield to access the chassis mount hole.

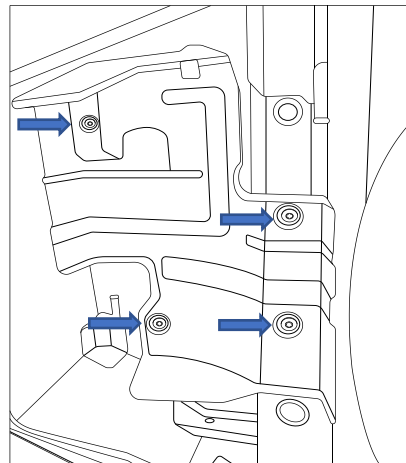

- 
9. Remove the rubber plug in the chassis holes.

Repeat for the other side

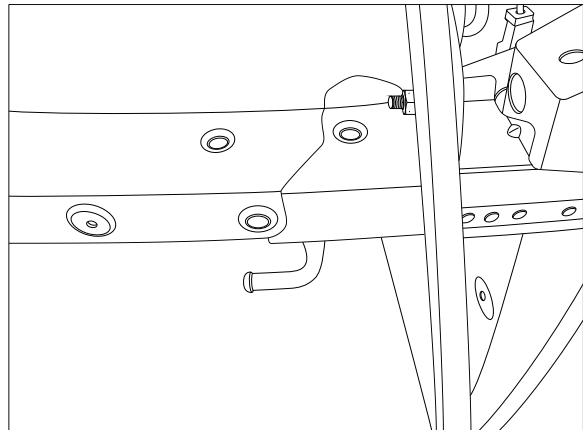

- 
10. Unclip and remove the bumper rearward.  
Disconnect the bumper sensor harness from the LHS.  
Disconnect the key transmitter connector.  
Remove 4x bolts and 2x nuts from the impact beam.  
Remove the key transmitter and discard the impact beam.

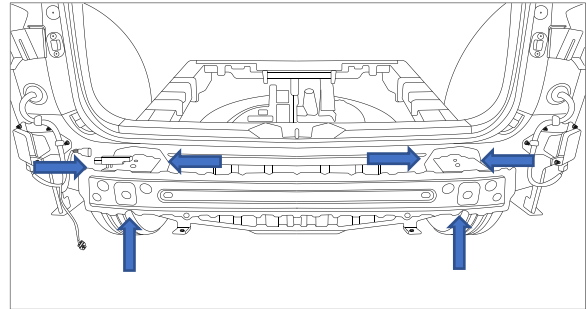

- 
11. Insert the side arm into the chassis and loosely secure with 3x M12 bolt and 3x washer.

Repeat for the other side.

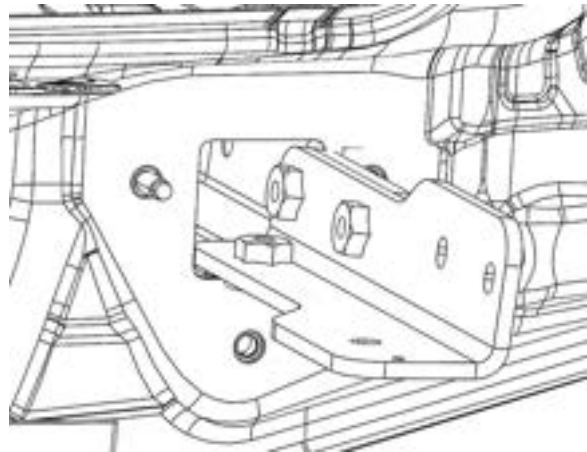

- 
12. Fit the cross tube between the side arms.  
Insert a spacer between each side arm and the cross tube.  
Loosely secure with 6x M12 bolts, 12x washers and 6 nuts.

Torque fasteners as follows:  
M12 x 1.75 = 109 Nm

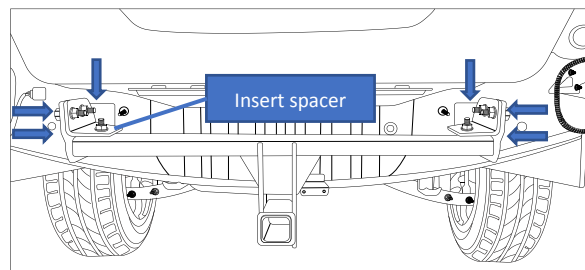

- 
13. Fit the key transmitter bracket and secure with a Tek screw.

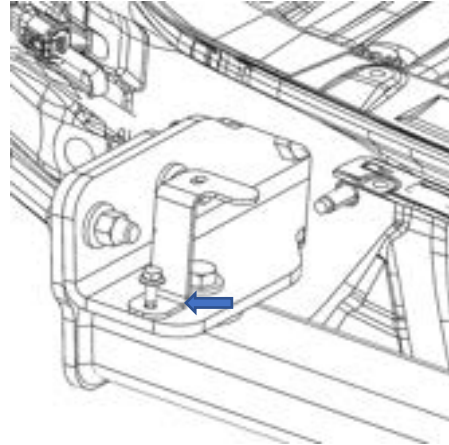

- 
14. Place masking tape on the bumper outer skin  
Mark and cut out an area 160mm x 90mm as shown to clear the hitch box.

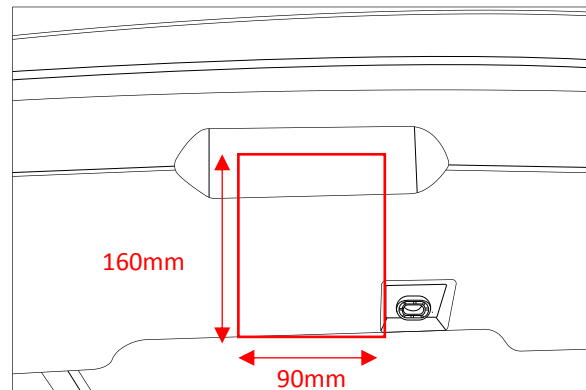

- 
15. Mark out and drill 2 x  $\varnothing$ 5mm holes 69mm apart on bumper skin to support plug bracket.

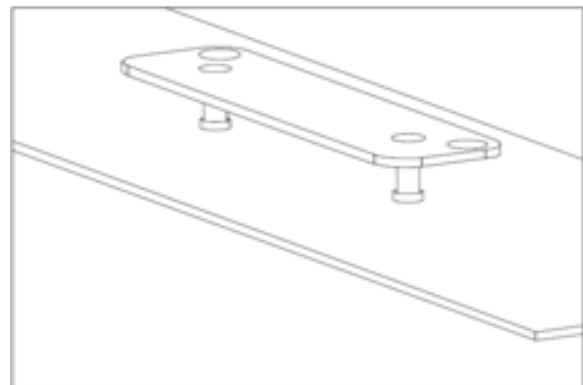



- 
16. Remove the grommet. Feed the tail harness connector through the hole.
  17. Slide the grommet to desired length from the socket. Secure the harness with supplied cable ties and ensure the grommet seated in the hole.

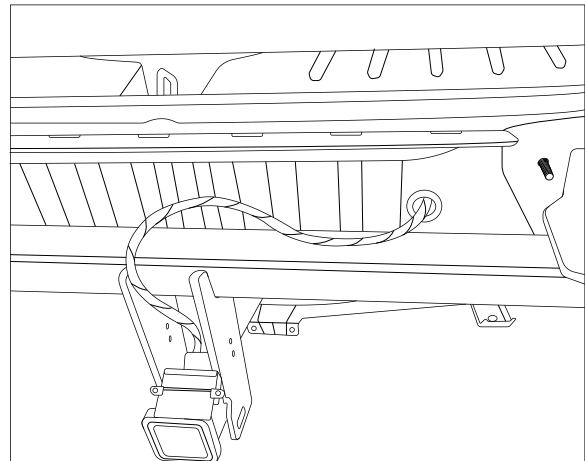

- 
18. In the boot remove the spare wheel floor cover.
  19. Remove the RHS floor trim.

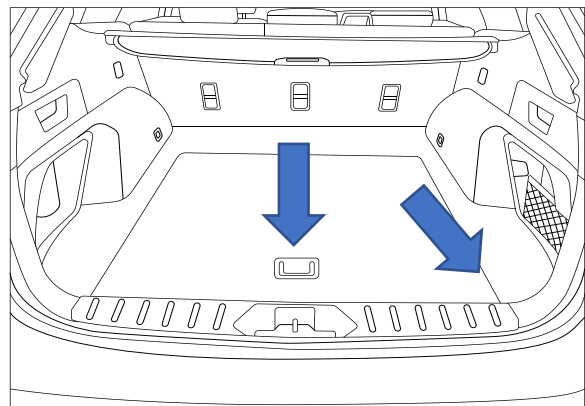

- 
20. Remove the RHS foam insert by removing 2x screws.

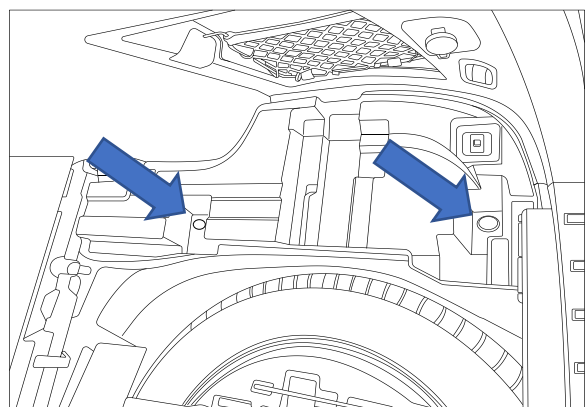

- 
21. At the rear RHS of the boot sill trim locate the 10-way trailer breakout connector.
  22. Plug in the trailer patch harness (102096-WL) into the 10-way connector.

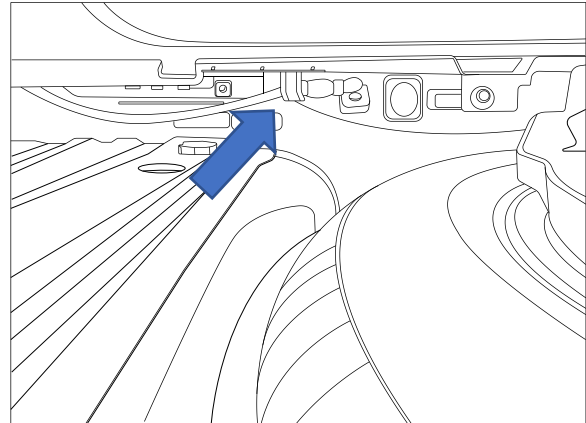

- 
23. Using the supplied alcohol wipe clean the sheet metal area and underside of the ECU.
  24. Connect the trailer patch 12-way connector to the ECU.
  25. Apply double sided tape to the ECU and secure to the sheet metal.

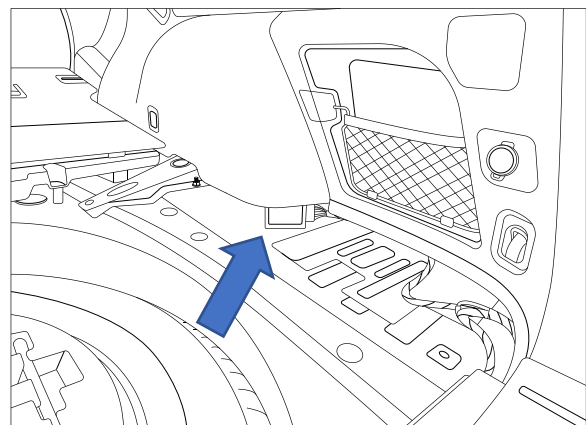

- 
26. Connect the tail harness 8-way connector to the trailer patch mating connector.
  27. Cut-off and crimp the tail harness GREY and GREY/BLACK wires to the trailer patch corresponding wire colours.
  28. Secure harness using cable ties.

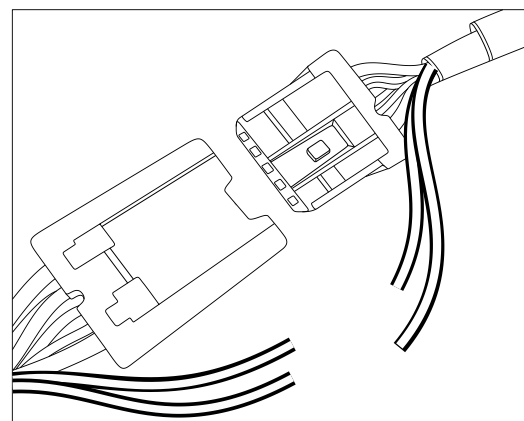

- 
29. Reconnect the negative battery terminal.
  30. Refit all previously removed parts from step 2 to 10 and the step 18 to 20 in the reverse order.
  31. Test the trailer patch function using a light board.
  32. To disable the RPA and RAB, can be activated and deactivated via the centre infotainment screen when vehicle is in reverse.
- Note: To disable you must press and hold the RPA and RAB buttons.**
33. Place fitting instructions in the glovebox after fitment.
- 

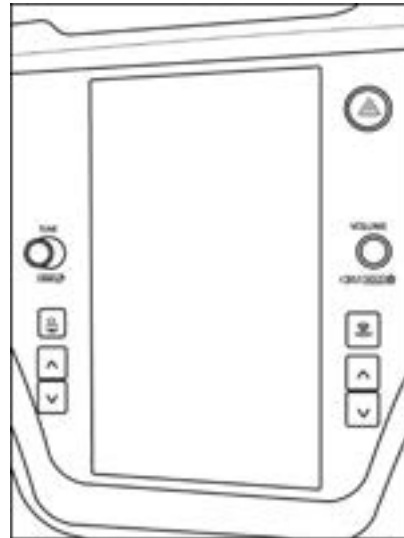



## CUSTOMER INFORMATION

PLACE THESE INSTRUCTIONS IN THE VEHICLE'S GLOVEBOX AFTER INSTALLATION

**THANK YOU FOR PURCHASING TRAILBOSS. WITH CORRECT MAINTENANCE AND CARE THIS PRODUCT WILL PROVIDE A LIFETIME OF TROUBLE-FREE OPERATION.**

### TOWBAR MAINTENANCE AND CARE:

- Trailboss recommend that the towbar LUG or TBM (Trailer Ball Mount) Pull Pin and R-clip are removed and stored when not in use. Removal of LUG or TBM (Trailer Ball Mount) is advisable when not in use to assist with any of the following.
  - Ensure rear number plate is not obscured.
  - Allow maximum available departure angle and prevent any potential interference.
  - Prevent possible interference with vehicles reverse sensors or camera detecting a tow ball mount as an obstruction during reversing.
  - Removes towball mount as an obstruction for when moving around the rear of the vehicle.
- Trailboss recommends routine inspection of your towbar to ensure trouble free towing.
  - Bolt security and tension should be regularly inspected and checked for correct tension. Replace any worn or defective parts with suitable grade & class fasteners. Inspection should be requested to coincide with vehicle major services.
- It is the owner's responsibility to ensure towing and down ball weight capacities of the towing vehicle are not exceeded.
  - Towing and down ball weights allowable may differ according to model variations. Please refer to owner's manual or vehicle dealer to confirm exact rating for your vehicle model variant.
  - It is not uncommon for the vehicle tow rating to differ from the towbar rating. When this occurs, the lesser rating must be adhered to.
  - For vehicles fitted with enhanced vehicle functions that may be altered/changed when towing i.e Trailer sway mitigation, blind spot detection, adaptive cruise control etc. Please consult owner's manual to understand changes enabled when towing and after towing.

### WARRANTY INFORMATION:

Trailboss Towbars are covered by a Lifetime Warranty.

Our goods come with guarantees that cannot be excluded under the Australian Consumer Law. You are entitled to a replacement or refund for a major failure and for compensation for any other reasonably foreseeable loss or damage. You are also entitled to have the goods repaired or replaced if the goods fail to be of acceptable quality and the failure does not amount to a major failure.

For further details please contact customer service on 1800 812 017.

## PRO SERIES SILENT ANTI-RATTLE HITCH PIN

Your Trailboss towbar is equipped with a Pro Series Silent Anti-Rattle Hitch Pin technology to help reduce towbar tongue rattle in most driving conditions. Please ensure below instructions are understood and routine maintenance is carried out to ensure best towing experience.

Regularly inspect for wear and check the tightness of the Silent Anti-Rattle Hitch Pin. Follow instructions below to re-tighten the nut as necessary when movement and noise in the tow ball mount is noted.

- Before towing, ensure R-Clip is properly installed and hitch pin nut is installed and tensioned. Replacement parts are available from your Pro Series Distributor.

## TOWBALL MOUNT REMOVAL/INSTALLATION

### STEP 1

Insert Trailer Ball Mount (TBM) (a) into towbar hitchbox (b), aligning hole in TBM shank (c) with hole in hitchbox (d) (Fig. 1)

### STEP 2

Insert Silent Anti-Rattle Hitch Pin (e) through hole in hitchbox and hole in TBM shank (g); ensure the locators are inserted into the notches in the hitchbox (Fig. 2)

### STEP 3

Screw Silent Anti-Rattle Hitch Pin Nut (f) onto Smart Pin (g); tighten Smart Pin Nut until finger tight, ensuring TBM is restrained from up and down movement.

### STEP 4

Tighten Silent Anti-Rattle Hitch Pin Nut by turning nut a further 1/8th of a turn in the clockwise direction using a 24mm spanner (Fig. 4).

### STEP 5

Install Silent Anti-Rattle Hitch Pin R-Clip through the hole that provides best clearance or easiest access. (Fig. 5)

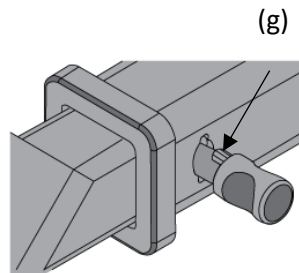
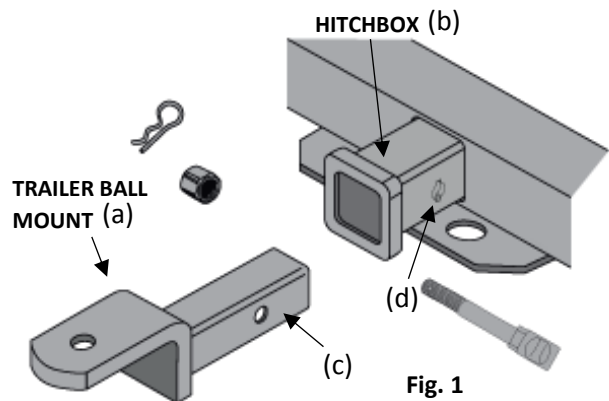

Fig. 2

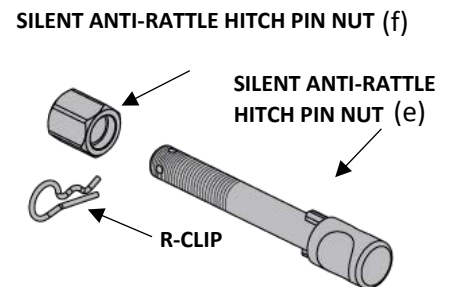

Fig. 3

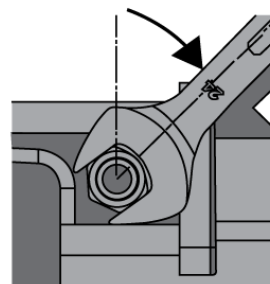

Fig. 4

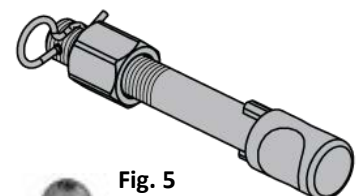

Fig. 5

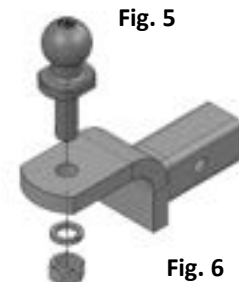

Fig. 6