

TRAILBOSS

Towbar Fitting Instructions
To Suit **SKODA YETI 01/2012 ON**
Part Number **QTSK002L**
Rating **1800/80 kg**

PLACE THESE INSTRUCTIONS IN THE VEHICLE'S GLOVEBOX AFTER INSTALLATION IS COMPLETE

WARNING:

1. Do not, drill, cut, weld or otherwise modify the tow bar.
2. If you are using electric welding on a motor vehicle, **always** check that the vehicle is not equipped with electronic engine or instrument management equipment. Failure to do so could **destroy** any onboard computers. If in doubt, check with the vehicle's manufacturer.
3. The high tensile fasteners supplied with this product were used to achieve the specified rating. If replacement is required ensure that fasteners of the same rating & quality are used. Contact an authorised **Trailboss** dealer if further information is required.

General:

1. Ensure all hardware items have been included refer to assembly diagram.
2. It is recommended that the instructions are read through and completely understood before making any attempt to fit this product.
3. Be wary of any changes to vehicle designs or other accessories that may conflict with the installation of this product.
4. Before drilling ensure that the area is clear of fuel, electrical & other components.
5. All holes drilled into the body panels shall have all burrs & swarf removed then coated with a suitable rust preventative paint.
6. For vehicles that require the bumper to be cut. Ensure cut out area is in correct position on the vehicle prior to cutting the bumper.
7. The high tensile fasteners supplied with this product were used to achieve the specified rating. If replacement is required ensure that fasteners of the same rating & quality are used. Contact an authorized **Trailboss** dealer if further information is required.
8. Ensure that all hardware is fastened to torque list below check fasteners on regular basis.
9. Tow bar load rating sticker provided with this product shall be conspicuously located on inside rear end of the driver's door. **(See diagram below)**.
10. Trailboss recommends that you check your tow ball to ensure that it complies with the Australian standards **AS 4177.2**.
11. **PLEASE NOTE:** It is advised to remove your lug or tbm when not actually towing so as to produce a clear view of the vehicles registration plate if obscured, and to also provide maximum available departure angle
12. Pull Pin must be fit in down position.

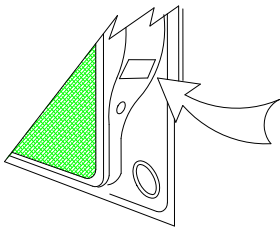

Place load rating sticker
inside driver's door here

FOR TRAILER TOWING PURPOSES ONLY
For towing capacity details please refer to vehicle owner's manual or to the manufacturer. Overloading can void your warranties.

RECOMMENDED ASSEMBLY TORQUE LISTING

Diameter	Grade 8.8 Bolt
M6	9.5 Nm
M8	21.7 Nm
M10	43.4 Nm
M12	77.3Nm
M14	146 Nm
M16	189.8 Nm

Tow bar Maintenance and Care.

Trailboss recommends that bolt torque's, as listed below, are routinely and regularly inspected and checked for correct tension. Replace any worn or defective parts.

We recommended to remove Tow Ball Mounts (TBM's, tongues or lugs) when not being used for any considerable length of time.

So as to avoid injury, when not towing it is suggested that the tongue, Pull Pin and R-clip are removed then stored in a safe, clean and dry place, away from excessive moisture.

Hitch Pull Pins and spring "R" clips are regularly checked for proper installation. Replace any worn or defective parts.

TRAILBOSS

Towbar Fitting Instructions
 To Suit **SKODA YETI 01/2012 ON**
 Part Number **QTSK002L**
 Rating **1800/80 kg**

PLACE THESE INSTRUCTIONS IN THE VEHICLE'S GLOVEBOX AFTER INSTALLATION IS COMPLETE

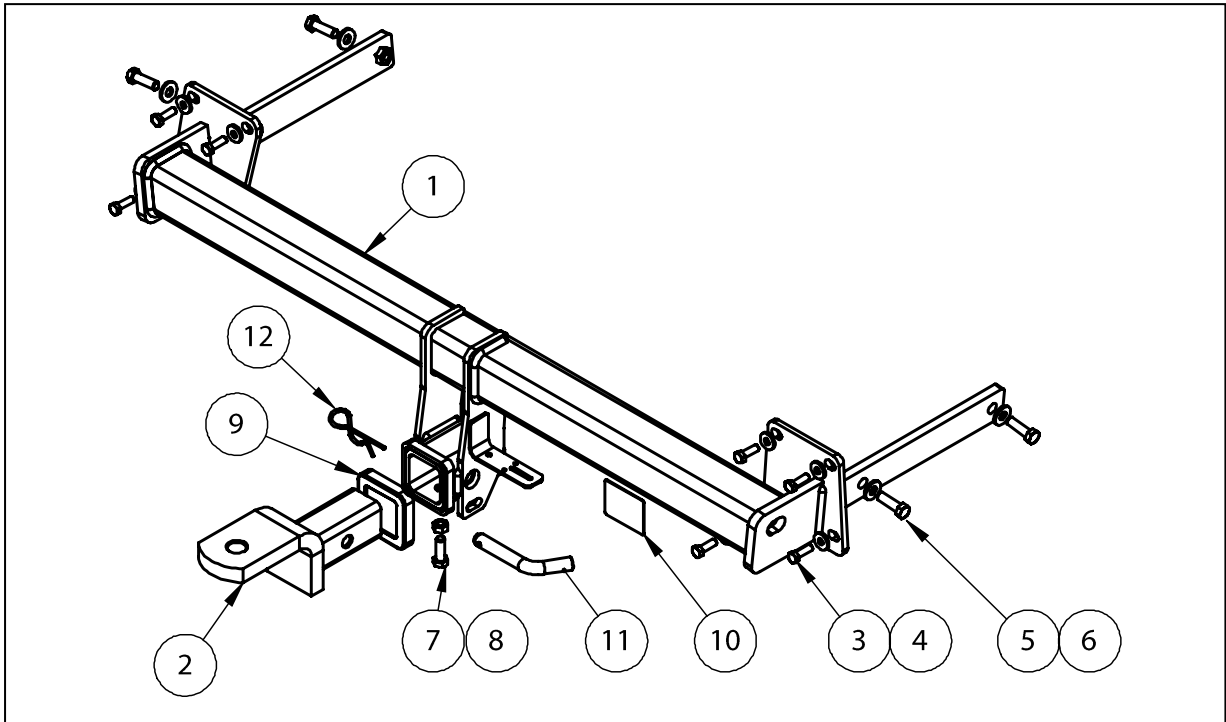

QTY.	DESCRIPTION	ITEM NO.
1	WELDED ASSY	1
1	TBM	2
7	M8 x 22 x 3.3 mm FLAT WASHER	3
7	BOLT M8 x 25	4
4	M10-1.5 x 35mm BOLT	5
4	WASHER FLAT M10 x 25.4 x 3	6
1	SET SCREW HEX HD M10x30x1.5P	7
1	HEX NUT M10 x 1.5	8
1	H/BOX C/COVER RL	9
1	CP LABEL	10
1	PULL PIN	11
1	R CLIP	12

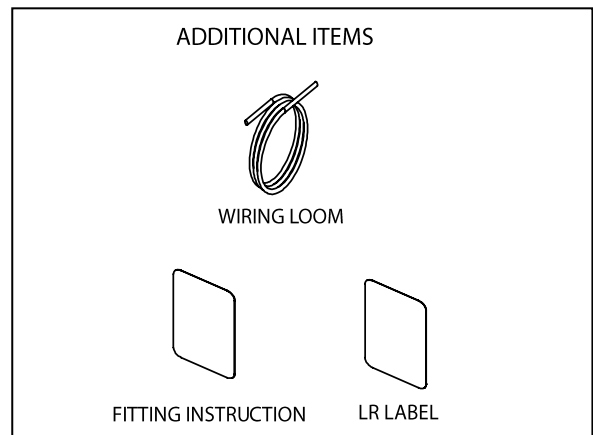



Towbar Fitting Instructions
To Suit **SKODA YETI 01/2012 ON**
Part Number **QTSK002L**
Rating **1800/80 kg**

PLACE THESE INSTRUCTIONS IN THE VEHICLE'S GLOVEBOX AFTER INSTALLATION IS COMPLETE

INSTRUCTION:

1. Remove 4 x Scrivets from inside of the rear RHS Wheel Arch. Repeat for the LHS.
2. Remove 5 x Scrivets from underneath of the Rear Bumper.
3. Open Tailgate and release cover underneath LHS Tail Light. Remove two Nuts.
Repeat for RHS.
4. Carefully remove Rear Bumper and place in a safe place.
Remove 7 x Torx Head Bolts to remove Impact Beam. Discard Impact Beam and Torx Head Bolts.
5. Offer Towbar to vehicle, inserting Towbar through openings in vehicle Rear Panel.
Loosely fasten 7 x M8 Bolts and Washers onto the Back Panel.
6. Loosely fasten 2 x M10 Bolts and Washers through the LHS Chassis Rail. Repeat for RHS.
Tighten all fasteners to the torque specifications on Page 1.
7. Remove opening on underside of Rear Bumper.
Reassemble Bumper assembly using steps 1 to 3 in reverse.



Wiring Loom Fitting Instructions
To Suit Skoda Yeti
Part Number 100877-WL

Wiring Loom Installation Instructions

Skoda Yeti
Part No: 100877-WL

Tail Harness Length Required: 1200mm
ECU Required: 04826

Wiring Loom Installation Time: Approx 30 Mins

Wiring Loom Fitting Instructions To Suit Skoda Yeti Part Number 100877-WL

1. In the luggage compartment, remove the parcel shelf and the carpet cover.
2. Release the wheel fasteners and remove the spare wheel.
3. Remove the three foam trays, by removing the five clips and the two screws.
4. Remove the two fasteners securing the rear luggage compartment trim.
5. On the LHS of the luggage compartment, remove the upper 'D' pillar trim .
6. Remove the fasteners and the cargo barrier hook and dislodge the LHS luggage compartment trim.

Note: Ensure when dislodging the luggage compartment trim to disconnect the 12v light connector.

Repeat Steps 4, 5 and 6 for the RHS.

7. On the RHS rear quarter of the vehicle, locate the existing vehicle blanking grommet (1).

Note: If the existing grommet (1) is occupied, drill a Ø30mm hole (2) next to it.



8. Inside the vehicle cabin, remove the rear RHS passenger door trim.
9. Dislodge the RHS 'B' pillar trim .
10. Dislodge the front RHS kick panel and door sill trim.
11. Remove the driver's dash side access panel.

Wiring Loom Fitting Instructions To Suit Skoda Yeti Part Number 100877-WL

12. Behind the LHS tail light assembly, following the table below, connect the ezy-tap to the vehicle's corresponding wires, then connect the trailer patch terminal to the ezy-tap.

Function	Trailer Patch	Vehicle Connector
L.IND	YELLOW / BLACK	BLACK / WHITE
REVERSE	BLACK / WHITE	BLACK / BLUE
TAIL	BROWN / BLACK	GREY / BLACK
BRAKES	RED / BLACK	BLACK / RED

13. Route the Trailer Patch (P/No: 100877-WL) along the rear of the vehicle towards the RHS.

14. Behind the RHS tail light assembly, following the table below, connect the ezy-tap to the vehicle R.IND, then connect the trailer patch terminal to the ezy-tap.

Function	Trailer Patch	Vehicle Connector
R.IND	GREEN / YELLOW	BLACK / GREEN

15. Connect the TWH ground ring terminal to the vehicle's grounding point.

16. Apply double sided tape to the ECU (04826) and secure it to the vehicle sheet metal on the RHS of the luggage compartment on a suitable location.

17. Connect the trailer patch 12-way connector to the ECU.

Note: Ensure ECU connector is facing downwards.

18. Route the 'ORANGE' power wire along RHS of the rear passenger seat following the existing vehicle harness towards the front of the vehicle.

19. Continue routing the 'ORANGE' power wire along the existing vehicle harness up towards the fuse panel.

20. Inside the fuse panel, locate the 15-amp (1) fuse as shown and remove.

21. Insert the supplied 20-amp fuse (2) into the upper slot of the add-a-fuse (3) and insert the previously removed 15-amp fuse (1) into the bottom slot of the add-a-fuse (3).

22. Plug the add-a-fuse (3) into the previously removed 15-amp fuse slot.

23. Connect the power patch 1-way connector (4) into the add-a-fuse harness mating connector (5).

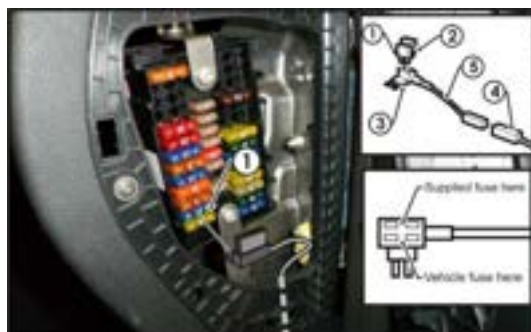



Wiring Loom Fitting Instructions
To Suit Skoda Yeti
Part Number 100877-WL

24. Mount the trailer socket to the tow bar mounting bracket using M4 fasteners (not supplied).
25. Route the tail harness across the tow bar towards the RHS of the vehicle and up through the previously drilled out hole.
26. Ensure the tail harness grommet is seated correctly and secure in place using a cable tie (not supplied).
27. Connect the tail harness (tail length 1200mm) 8-way connector to the TWH mating 8-way connector.
28. Test the TWH function using a light board or multi meter.
29. Secure all harnesses using cable ties (not supplied).
30. Re-fit all removed parts and secure all fasteners, ensuring there are no squeaks or rattles.
31. Place the fitting instructions in the glove box after fitment.