

TRAILBOSS

Towbar Fitting Instructions
To Suit **SKODA OCTAVIA NE WAGON 11-13 ON**
Part Number **QTSK003L**
Rating **1600/75 kg**

PLACE THESE INSTRUCTIONS IN THE VEHICLE'S GLOVEBOX AFTER INSTALLATION IS COMPLETED

WARNING:

1. Do not, drill, cut, weld or otherwise modify the tow bar.
2. If you are using electric welding on a motor vehicle, **always** check that the vehicle is not equipped with electronic engine or instrument management equipment. Failure to do so could **destroy** any onboard computers. If in doubt, check with the vehicle's manufacturer.
3. The high tensile fasteners supplied with this product were used to achieve the specified rating. If replacement is required ensure that fasteners of the same rating & quality are used. Contact an authorised **Trailboss** dealer if further information is required.
4. If TBM is used in inverted position tow ball may make contact with rear tailgate when lowered, which could cause damage.

General:

1. Ensure all hardware items have been included refer to assembly diagram.
2. It is recommended that the instructions are read through and completely understood before making any attempt to fit this product.
3. Be wary of any changes to vehicle designs or other accessories that may conflict with the installation of this product.
4. Before drilling ensure that the area is clear of fuel, electrical & other components.
5. All holes drilled into the body panels shall have all burrs & swarf removed then coated with a suitable rust preventative paint.
6. For vehicles that require the bumper to be cut. Ensure cut out area is in correct position on the vehicle prior to cutting the bumper.
7. The high tensile fasteners supplied with this product were used to achieve the specified rating. If replacement is required ensure that fasteners of the same rating & quality are used. Contact an authorized **Trailboss** dealer if further information is required.
8. Ensure that all hardware is fastened to torque list below check fasteners on regular basis.
9. Tow bar load rating sticker provided with this product shall be conspicuously located on inside rear end of the driver's door. **(See diagram below).**
10. Trailboss recommends that you check your tow ball to ensure that it complies with the Australian standards **AS 4177.2**.
11. **PLEASE NOTE:** It is advised to remove your lug or tbm when not actually towing so as to produce a clear view of the vehicles registration plate if obscured, and to also provide maximum available departure angle
12. Pull Pin must be fit in down position.

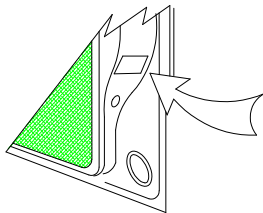

Place load rating sticker
inside driver's door here

FOR TRAILER TOWING PURPOSES ONLY
For towing capacity details please refer to vehicle owner's manual or to the manufacturer. Overloading can void your warranties.

RECOMMENDED ASSEMBLY TORQUE LISTING

Diameter	Grade 8.8 Bolt
M6	9.5 Nm
M8	21.7 Nm
M10	43.4 Nm
M12	77.3Nm
M14	146 Nm
M16	189.8 Nm

Tow bar Maintenance and Care.

Trailboss recommends that bolt torque's, as listed below, are routinely and regularly inspected and checked for correct tension. Replace any worn or defective parts.

We recommended to remove Tow Ball Mounts (TBM's, tongues or lugs) when not being used for any considerable length of time.

So as to avoid injury, when not towing it is suggested that the tongue, Pull Pin and R-clip are removed then stored in a safe, clean and dry place, away from excessive moisture.

Hitch Pull Pins and spring "R" clips are regularly checked for proper installation. Replace any worn or defective parts.

TRAILBOSS

Towbar Fitting Instructions
 To Suit **SKODA OCTAVIA NE WAGON 11-13 ON**
 Part Number **QTSK003L**
 Rating **1600/75 kg**

PLACE THESE INSTRUCTIONS IN THE VEHICLE'S GLOVEBOX AFTER INSTALLATION IS COMPLETED

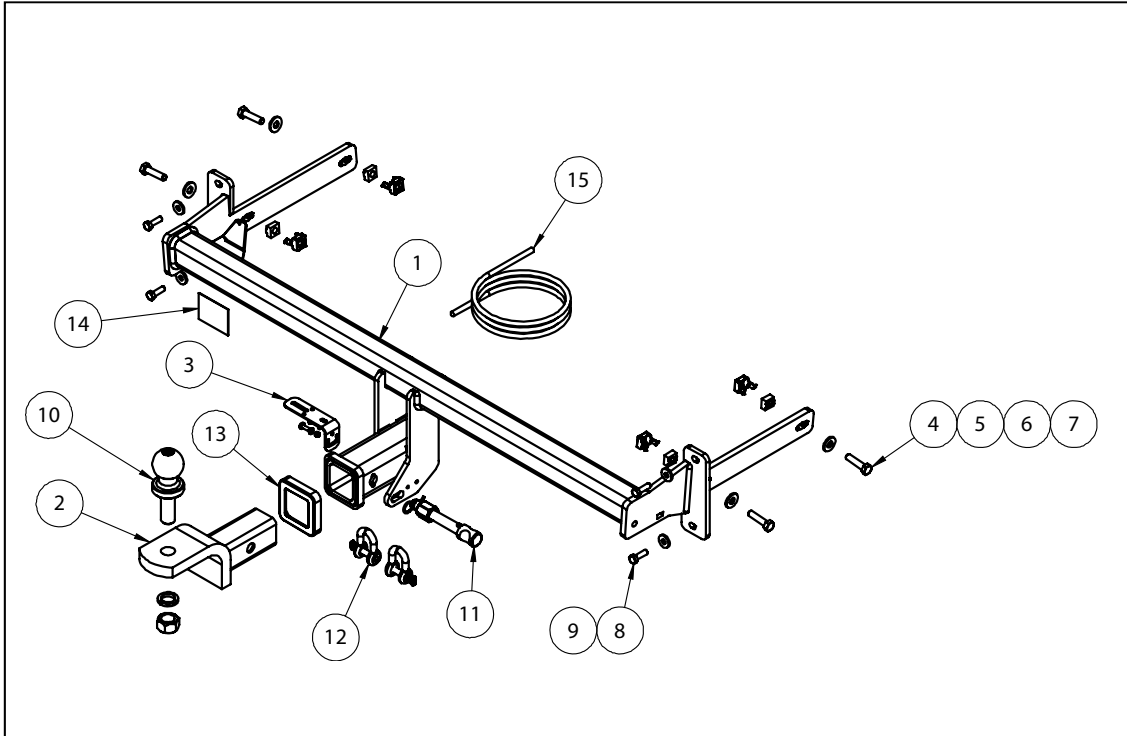

QTY.	DESCRIPTION	ITEM NO.
1	WELDED ASSY	1
1	TBM ASSY	2
1	UNIVERSAL PLUG BRACKET KIT	3
4	BOLT M12-1.5x40mm	4
4	WASHER FLAT M10x25.4x3	5
4	CAGE NUT M10X1.5	6
4	CAGE NUT RETAINER	7
4	SET SCREW M8x25	8
4	FLAT WASHER M8x22x3.3mm	9
1	50mm TOWBALL	10
1	SILENT HITCH PIN - SILVER	11
2	10mm "D" SHACKLE	12
1	HITCH BOX COLLAR COVER	13
1	ACRYLIC CP	14
1	WIRING LOOM	15



Towbar Fitting Instructions
To Suit **SKODA OCTAVIA NE WAGON 11-13 ON**
Part Number **QTSK003L**
Rating **1600/75 kg**

PLACE THESE INSTRUCTIONS IN THE VEHICLE'S GLOVEBOX AFTER INSTALLATION IS COMPLETED

INSTRUCTION:

1. Remove 4x Screws in rear wheel arch. Perform for both sides of vehicle.
2. Remove 2x Screws from Bumper trim under right side of vehicle.
3. Remove 4x Screws from Bumper trim under rear of vehicle.
4. Remove cover over Screw in the tail light assembly in boot cavity. Remove newly exposed screw.
5. Remove trim in boot cavity adjacent to tail light assembly. Remove 2x exposed Screws securing tail light assembly.
6. Repeat steps 4 and 5 for opposite side of vehicle.
7. Unplug tail lights and remove tail light assembly. Perform for both sides of vehicle.
8. Unclip and remove Bumper skin, disconnecting the parking sensors as Bumper is removed.
9. Remove and discard 3x Screws from impact beam on LHS of vehicle and 4x Screws from impact beam on RHS of vehicle. Remove and discard impact beam.
10. Install Cage Nuts onto side arms of towbar in the 4 profiled holes.
11. Place Towbar inside chassis rails. Loosely secure Towbar to side of chassis rails with 2x M10 x 40 bolts. Loosely secure Towbar to rear panel with 2x M8 x 25 Set Screws. Perform for both sides of vehicle. Tighten all fasteners to torque specified on page 1 of this document.
12. Secure plug bracket to LHS of Hitch receiver using fasteners provided.
13. Determine centre of Bumper. Make 95mm wide cut in Bumper starting from lower edge of bumper through to the bumper window. Make a 95mm wide cut in bumper starting from edge of bumper window 50mm high.
14. Refit Bumper skin by following steps 1-8 in reverse order.



Wiring Loom Fitting Instructions
To Suit Skoda Octavia Wagon
Part Number: 101271-WL

Wiring Loom Installation Instructions

Skoda Octavia Wagon
Part No: 101271-WL

Tail Length Required: 1200mm

ECU Required Part No: 04828

Wiring Loom Installation Time: Approx 30 Mins

TRAILBOSS

Wiring Loom Fitting Instructions To Suit Skoda Octavia Wagon Part Number: 101271-WL



Due to possible vehicle variations, always confirm any noted vehicle colour wires with a multi-meter to ensure the correct function is identified before soldering or scotch locking.

1. In the luggage compartment, remove the floor cover carpet.
2. Remove the parcel shelf and fold the rear seats forward.
3. Remove the luggage compartment rear trim.
4. Remove the driver's side rear passenger arm rest trim.
5. Remove the RHS luggage compartment upper plastic trim fasteners and then remove the trim.
6. Remove the RHS luggage compartment carpeted trim fasteners and then dislodge the carpeted trim. Repeat for the LHS.
7. Dislodge the 'B' pillar lower trim and remove the front passenger side scuff trim.
8. Remove the passenger dash side trim and the glove box.
9. Near the 'A' pillar area, remove passenger dash side trim and the glove box.
10. At the exterior RHS rear quarter, near the vent, locate and remove the vehicle grommet. If the grommet hole is occupied, choose a suitable location next to the existing grommet and drill a Ø30mm hole. Apply rust inhibitor after drilling (not supplied).
11. Locate the vehicle RHS tail light harness inside the vehicle. Following the table below, connect the ezy-taps to the corresponding vehicle wires, then connect the trailer patch (P/No: 101271-WL) terminals to the ezy-taps. Due to possible vehicle variations, ensure to use a multi-meter to determine the correct signals.

Function	Trailer Patch	Vehicle Wire
R.IND	GREEN / BLACK	GREEN / BLACK
REVERSE	BLACK / WHITE	BLACK / BLUE
TAIL BRAKES	RED / BLACK	WHITE / BLACK

12. Route the trailer patch LHS branch along the rear of the vehicle and across to the LHS tail light connectors.
13. Connect the trailer patch connector to the ECU. Remove the backing from the back of the ECU and mount the ECU onto a suitable location on the RHS rear quarter sheet metal area where it will not be an obstruction. **Ensure ECU is mounted with the connector end pointing downwards.**

Wiring Loom Fitting Instructions To Suit Skoda Octavia Wagon Part Number: 101271-WL

14. Locate the vehicle LHS tail light harness. Following the table below, connect the ezy-tap to the corresponding vehicle wire, then connect the trailer patch terminal to the ezy-tap. Due to vehicle variations, ensure to use a multi-meter to determine the correct signals.

Function	Trailer Patch	Vehicle Wire
L.IND	YELLOW / BLACK	GREY / PURPLE

15. Secure the trailer patch ground ring terminal to the vehicle sheet metal at a suitable location using a tek screw (not supplied).

16. Remove the indicated vehicle 10A fuse (1). Insert the vehicle fuse 10A fuse (1) and the supplied 20A fuse (2) to the add-a-fuse harness (3). Connect the trailer patch 1-way connector (4) to the add-a-fuse harness (3). Insert the add-a-fuse harness (5) to the previously removed fuse location (6).

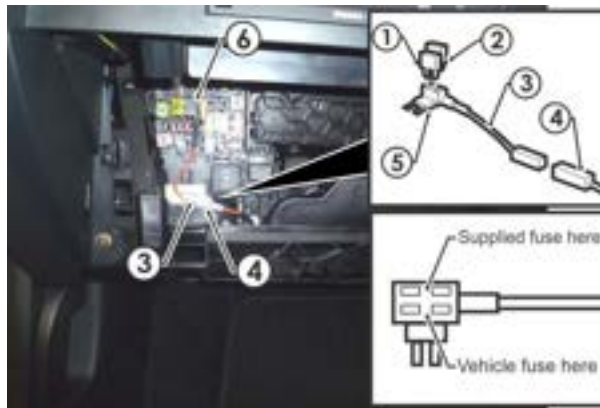

17. At the rear exterior of the vehicle, mount the tail harness socket to the towbar mounting bracket using M4 fasteners (not supplied).

18. Route the tail harness (tail length: 1200mm) across the RHS and up into the drilled out (or existing) grommet hole. Adjust the trailer patch harness grommet so that it is seated correctly and cable tie (not supplied) in place.

19. Connect the tail harness 8-way connector to the trailer patch 8-way mating connector.

20. Test the Trailer patch harness using a light board or multi-meter.

21. Secure all harnesses using cables ties (not supplied).

22. Re-fit all removed parts and secure all fasteners.

23. Place instructions in glove box after fitment.



FITTING INSTRUCTIONS

Silent Anti-Rattle Hitch Pin (PR0001)

• These fitting instructions are supplied to ensure understanding of how the HITCH PIN should be fitted and used correctly.

• Once installed, we recommend **ALL** instructions are kept and placed in the vehicle glove box.

NOTE: Routine maintenance and inspection of the towbar & HITCH PIN is required. Regularly inspect for wear and check the tightness of the Hitch Pin. Follow instructions below to retighten the nut when necessary.

***Do not tow with your vehicle if the R CLIP or the HITCH PIN is loose or missing. Replacement parts are available from your Pro Series Distributor.**

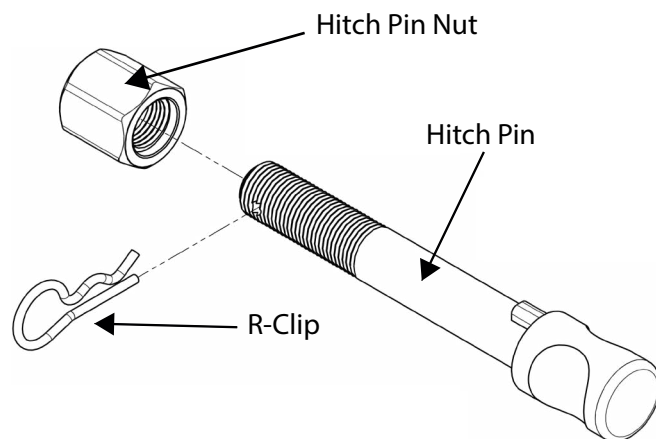

Fig 1. Silent Anti-Rattle Hitch Pin assembly

STEP 1

Insert Trailer Ball Mount (TBM) into towbar HITCHBOX, aligning hole in TBM SHANK with hole in HITCHBOX (Fig 2).

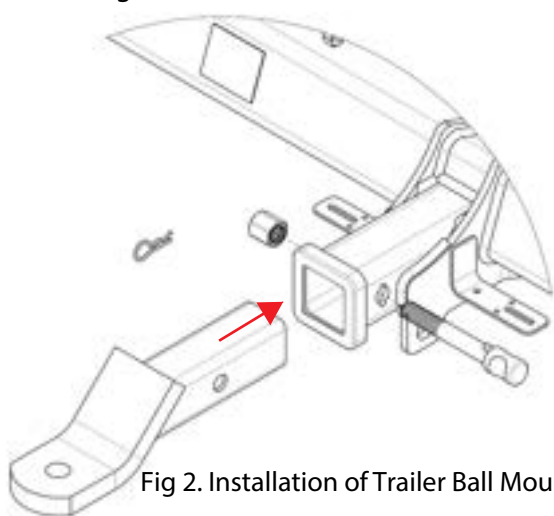

Fig 2. Installation of Trailer Ball Mount

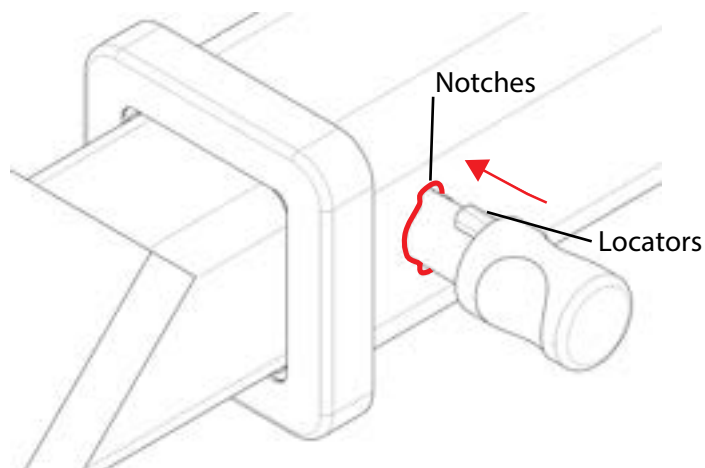

Fig 3. Silent Anti-Rattle Hitch Pin orientation

STEP 2

Insert HITCH PIN through hole in HITCHBOX and hole in TBM SHANK; ensure the LOCATORS are inserted into the NOTCHES in the HITCHBOX (Fig. 3).

STEP 3

Screw HITCH PIN NUT onto HITCH PIN; tighten HITCH PIN NUT until finger tight, ensuring TBM is restrained from movement.

STEP 4

Tighten HITCH PIN NUT by turning nut a further 1/8th of a turn in the clockwise direction using a 24mm spanner (Fig. 4).

STEP 5

Install HITCH PIN R CLIP through the hole on the HITCH PIN (Fig. 1).

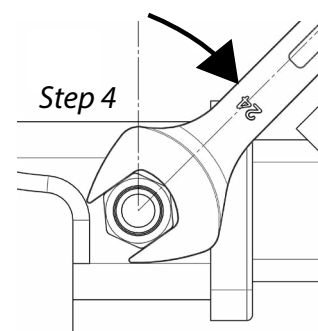

Fig 4. Tightening of Silent Anti-Rattle Hitch Pin Nut