

TRAILBOSS

Towbar Fitting Instructions To Suit Ssangyong Kyron 4DR Wagon 02-06-ON Part Number QTSY206 Rating 2300 kg

WARNING:

1. Do not, drill, cut, weld or otherwise modify the tow bar.
2. If you are using electric welding on a motor vehicle, **always** check that the vehicle is not equipped with electronic engine or instrument management equipment. Failure to do so could **destroy** any onboard computers. If in doubt, check with the vehicle's manufacturer.

- 1 Ensure all hardware items have been included.
- 2 Lower rear muffler from rear most rubber hangers.
- 3 Feed the six M12 bolts on wire through access hole on each side of the chassis rails to align with existing holes in the underside the chassis rails let bolts drop through holes see fig 1.
- 4 Unbolt the support arms as shipped & discard M10 X 40 bolt, flat washers & nut see fig 2.
- 5 Fasten support arms each side to underside of side plates see fig 3 using M12 x 35 bolts, nuts & washers supplied.
- 6 Offer tow bar to the underside of the chassis rails while maneuvering the bar away from the rear muffler to align holes in the side plates with the M12 bolts dropped through the chassis rails.
- 7 Fit M12 flat, spring washers with nuts supplied in six places fasten all hardware to torque listing below.
- 8 Trim any excess wire from bolts on wire feed through the chassis rails ensuring that there are no exposed or protruding edges.
- 9 Refit the rear muffler.
- 10 Tow bar load rating sticker to be conspicuously located on inside rear end of the driver's door. **(See diagram below)**
- 11

NOTE: Trailboss recommends that you check your towball to ensure it complies with the Australian standard AS 4177.2.

RECOMMENDED ASSEMBLY TORQUE LISTING

Diameter	Grade 8.8 Bolt
	Nm;
M6	9.5
M8	21.7
M10	43.4
M12	77.3
M16	189.8

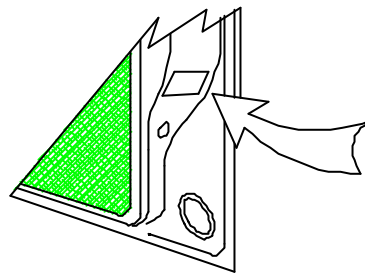

Place load rating
sticker inside
driver's door here

FOR TOWING PURPOSES ONLY
For towing capacity details please refer
to vehicle owner's manual or to the
manufacturer. Overloading can void
your warranties.

TRAILBOSS

Towbar Fitting Instructions To Suit Ssangyong Kyron 4DR Wagon 02-06-ON Part Number QTSY206 Rating 2300 kg

Fig 1

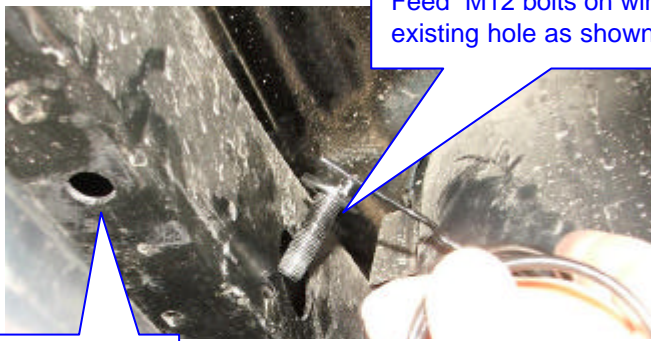

Existing holes on the underside of chassis rails.

Feed M12 bolts on wire through existing hole as shown.

Fig 2

1-M10 X 40 BOLT
2-M10 FLAT WASHERS
1-M10 NUT
FOR TRANSPORT PURPOSES ONLY
TO BE DISCARDED BY THE INSTALLER

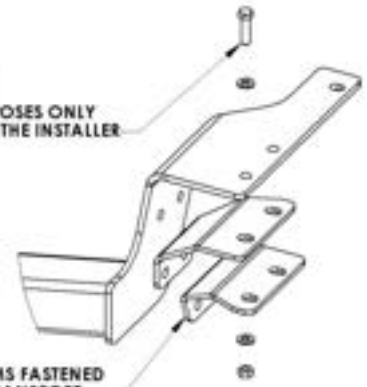

2-SUPPORT ARMS FASTENED
FOR EASE OF TRANSPORT

Fig 3

