

PRODUCT DETAILS:

Part Number:	QTSY307L	Maximum Towing Braked:	3500	kg
ECU Number:	04835	Maximum Towing Unbraked:	750	kg
Tail Harness Length Required:	1200 mm	Maximum Static Ball Load:	350	kg
TBM/Lug Part Number:	21375			

FITTING DETAILS:

Towbar Installation Time:	90 Mins.	RPA Disable/Other:	YES
Total Installation Time:	120 Mins.		
Bumper Cut Required:	Yes		

Note:

- Use tail 04936 for RPA disable

TRAILBOSS RECOMMENDS THAT INSTRUCTIONS ARE READ AND UNDERSTOOD COMPLETELY PRIOR TO FITMENT.

BEFORE YOU START:

Check all hardware items have been included refer to assembly diagram.
Please ensure this towbar is only fitted to vehicle models as per Trailboss application guide.

Bumper Cuts

Vehicle and bumper variations can and do occur during vehicle manufacture after initial towbar design. Fitment of towbar to vehicle and accuracy of bumper cut must be assessed prior to any bumper modifications made. Incorrect bumper cuts are not covered under Trailboss warranty.

NOTE: Bumper cuts need to be approached with care, refer to notes below.

- Bumper centreline – where the centreline of the bumper needs to be determined, the installer must assess centre point by measurement of bumper width or determining two symmetrical reference points to give centreline.
- Bumper edge – To assist with accurate bumper cut measurement, reference to the start of the bumper edge is now being commonly used.
 - Measure from bottom edge along bumper and around corner to the 70 mm point (Figure 1).
 - Do not measure from visible bumper front of corner, upwards (Figure 2).

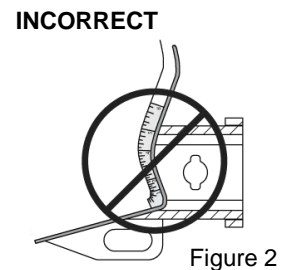
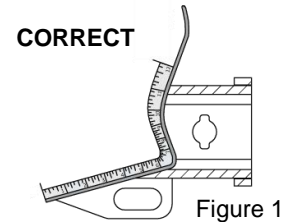

Drilling

- For any required drilling during installation, ensure that the area is clear of fuel, electrical & other components that may be damaged.
- All holes drilled into metal body panels shall have all burrs & swarf removed then coated with a suitable rust preventative paint.

Bolts/Fasteners

- Ensure that all hardware is fastened to correct torque as specified in this fitting instruction.
- All fasteners supplied with this product are used to achieve a specified clamp loading. If replacement is required ensure that fasteners of the same grade and class are used.

NOTE: Achieving correct torque is critical to proper installation and responsibility of the installer. Towbar failures attributed to tension issues from over tightening or under tightening are not covered by Trailboss warranty.

Product Labels

- a. Towbar load rating sticker provided with this product shall be conspicuously located on inside rear end of the driver's door.

WARNING:

Do not, drill, cut, weld or otherwise modify the towbar.

FOR TOWING PURPOSES ONLY - This towbar is designed and tested by Trailboss to adhere to ADR 62/02 which provides only for the expected load demands of towing.

PLACE THESE INSTRUCTIONS IN THE
VEHICLE'S GLOVEBOX AFTER INSTALLATION

i TOWBAR ASSEMBLY DIAGRAM

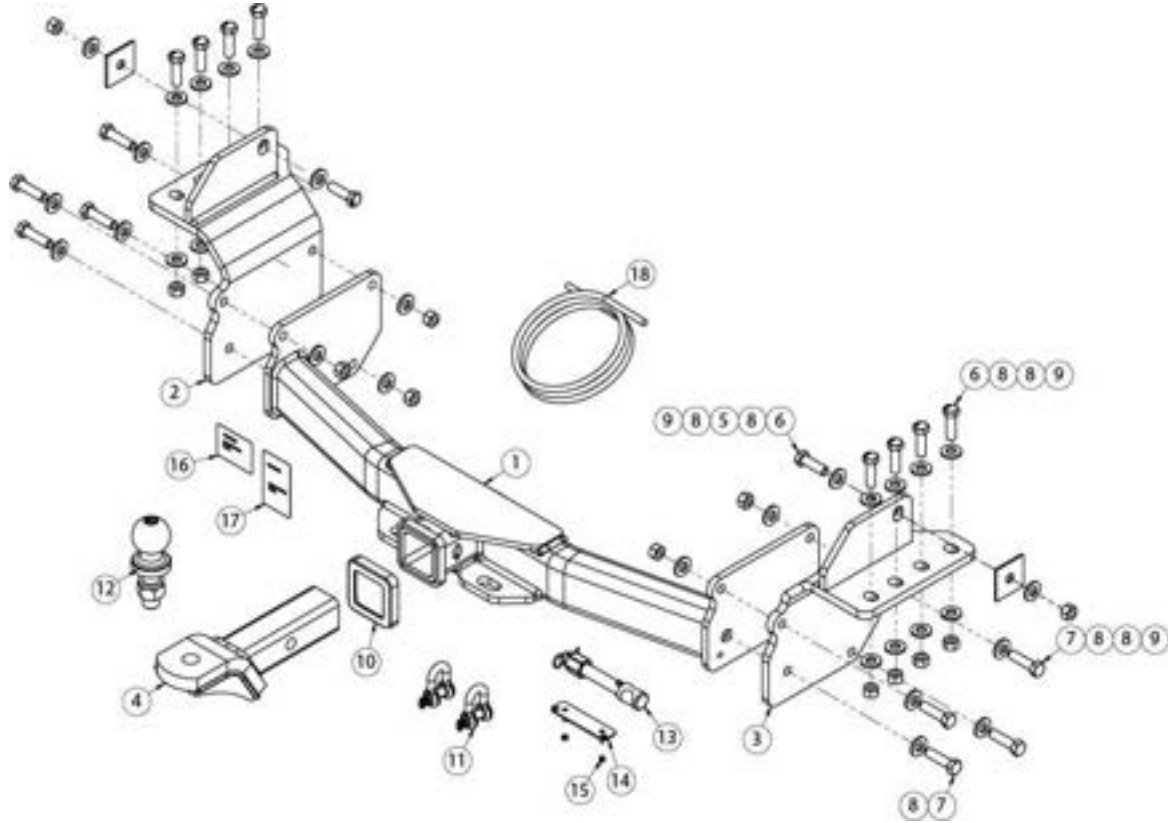

ITEM	DESCRIPTION	QTY
1	SSANGYONG MUSSO WELDED ASSY	1
2	SIDE ARM ASY LHS	1
3	SIDE ARM ASY RHS	1
4	TRAILER BALL MOUNT	1
5	LOOSE PLATE – COATED	2
6	SET SCREW HEX HD M12x40x1.75P	10
7	BOLT HEX HD M12x45x1.75P	8
8	WASHER PLAIN 1/2"	34
9	NUT HEX M12x1.75P	16

ITEM	DESCRIPTION	QTY
10	HITCH BOX COLLAR COVER	1
11	"D" SHACKLE 10mm	2
12	TOWBALL 50mm	1
13	SMART PIN SILVER	1
14	PLUG BRACKET	1
15	NUT NYLOC HEX HD M4x0.7P	2
16	COMPLIANCE LABEL	1
17	LOAD RATING LABEL	1
18	WIRE LOOM	1

1. Remove 2x screws and 1x scrivets attaching mudflap/wheel house liner to the rear bumper.

Repeat for the other side.

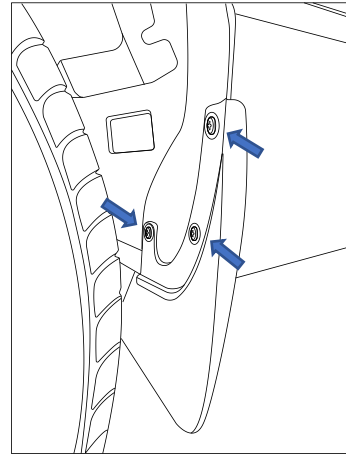

2. Remove 2x scrivets and 1x screw attaching mudflap/bumper to vehicle body.

Repeat for the other side.

Store Mudflaps safely to avoid damage.

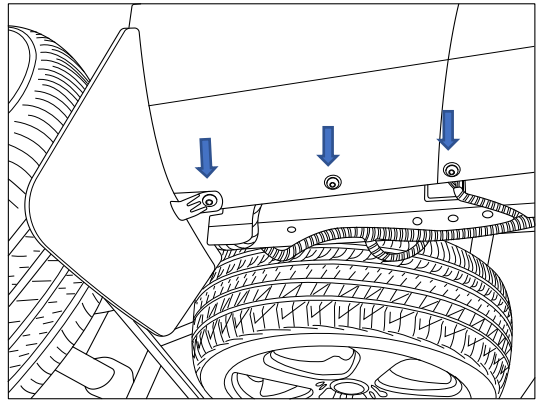

3. Remove 1x screw behind the wheelhouse liner attaching bumper to vehicle body.

Repeat for the other side.

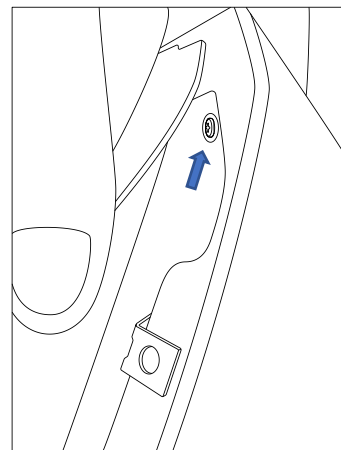

-
4. Remove 2x bolts attaching bumper to vehicle body.

Repeat for the other side.

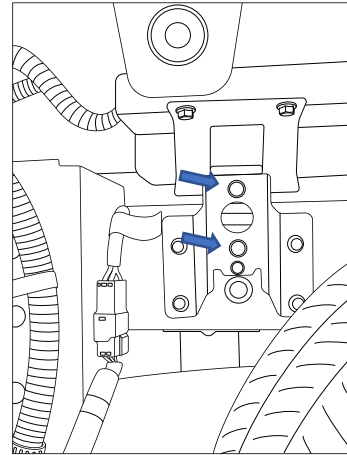

-
5. Unclip the wire harness from the chassis rail on LHS of Vehicle and disconnect the connectors.

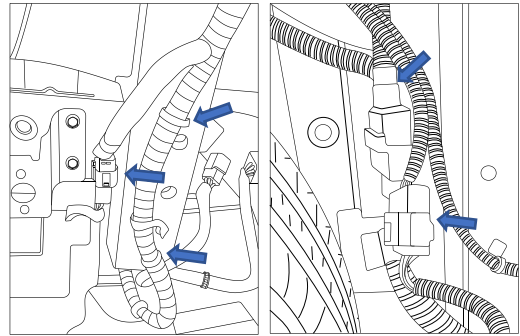

-
6. Unclip the LHS wire harness from rear corner of vehicle body and disconnect the connector.

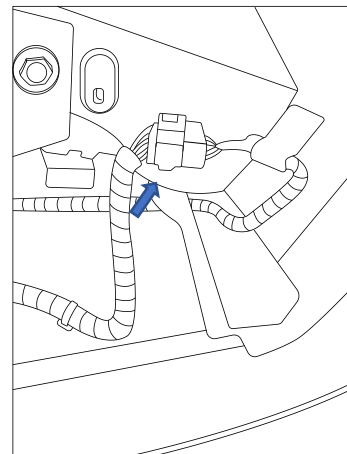

PLACE THESE INSTRUCTIONS IN THE VEHICLE'S GLOVEBOX AFTER INSTALLATION

-
7. Unclip the RHS wire harness from rear corner of vehicle body and disconnect the connector.

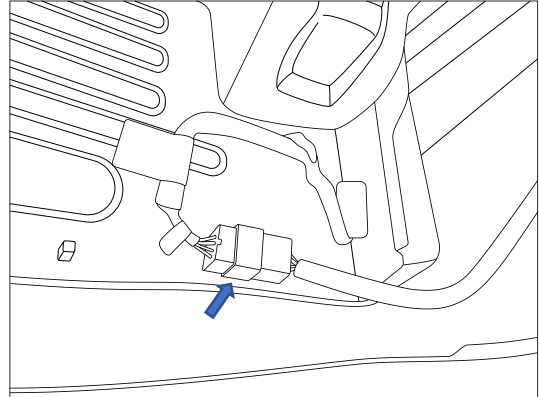

-
8. Peel back the side of the rear bumper attaching it to the rear quarter panel.

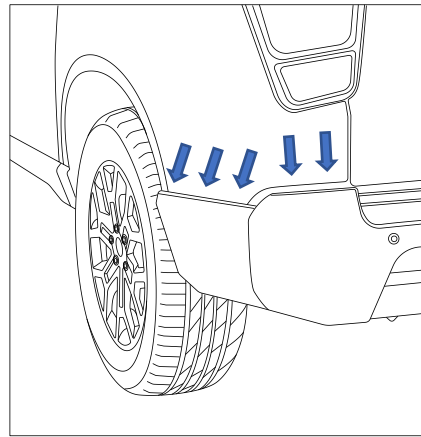

-
9. Remove the rear bumper.
Store safely to avoid damage to rear bumper.

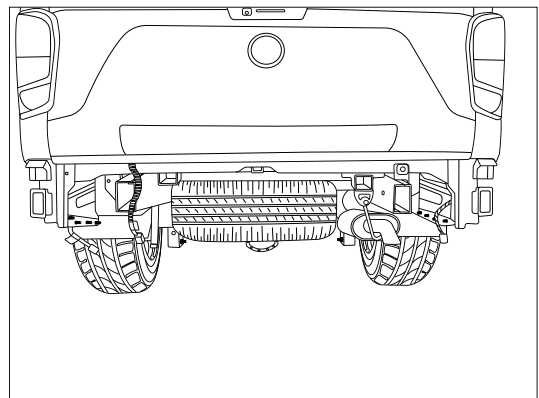

10. Using the wheel tool kit, lower the spare wheel.

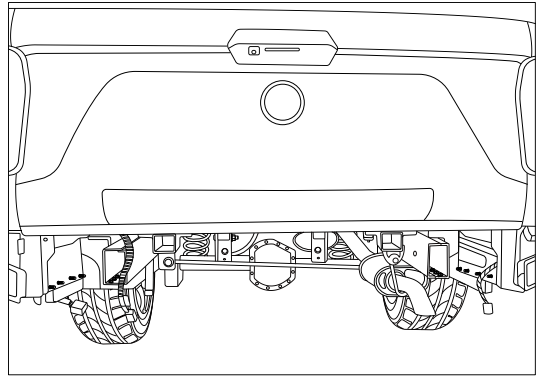

11. Using 1x M12 x 40 Bolt and 1x Washer, locate the side arm in position.

Repeat for the other side.

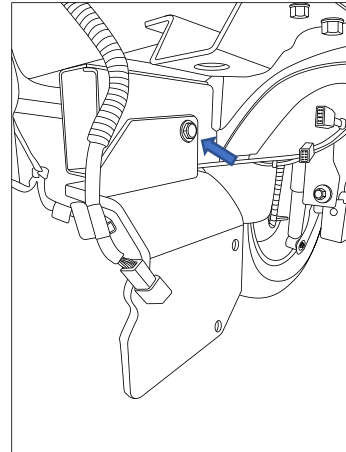

12. From the inside of the chassis rail loosely secure the side arm with 1x square support Plate, 1x Washer and 1x M12 Nut.

Loosely secure using 4x M12 x 40 Bolts, 8 x Washers and 8 x M12 Nuts.

Repeat for the other side.

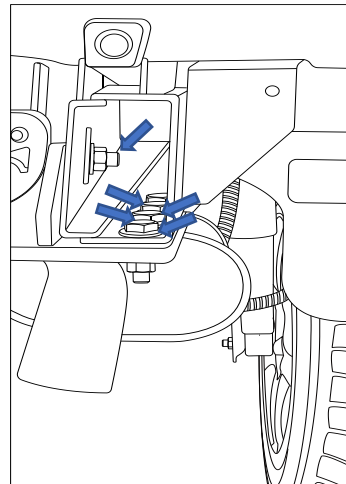

13. Fit the towbar to the side arms and loosely secure using 8x M12 x 45 Bolts, 14 x M12 Washers and 6x M12 Nuts.

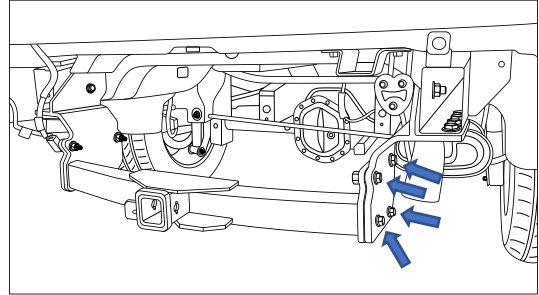

14. Torque all fasteners as assembled in steps 12 & 13 on both sides as follows:

M12 x 1.75P = 109Nm

15. Trim the rear bumper tabs off along the edge of the rear bumper as shown.
16. Trim the rear impact beam tabs off along the impact beam edge as shown.

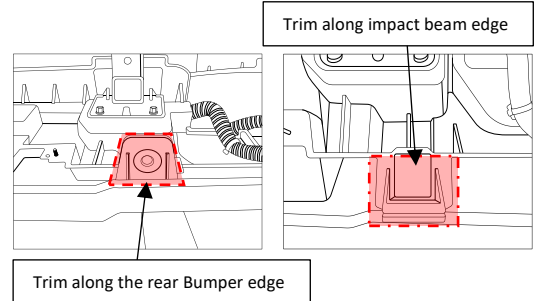
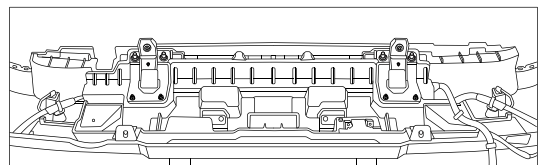

17. Refit the spare wheel ensuring the spare wheel has sufficient clearance to the towbar
18. Re-assemble the rear bumper & mudflaps, ensuring there are no squeaks or rattles following steps 1-10, in reverse.

Note: Store the LUG or TBM (Tow ball Mount), Towball and Smart Pin when not in use

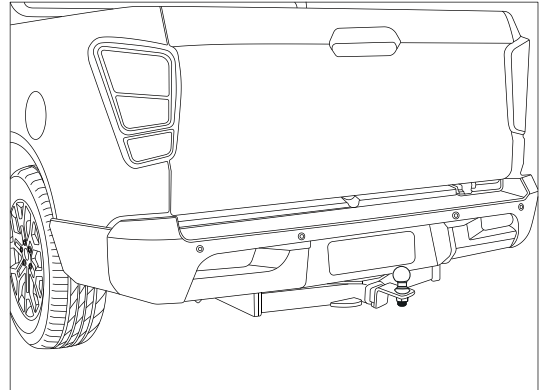

IMPORTANT

Due to possible vehicle variations, always confirm any noted vehicle colour wires with a multi-meter to ensure the correct function is identified before soldering or scotch locking. For vehicle wires denoted with two colours (example; RED/GREEN) the first colour will always be the main wire colour while the second colour is the thinner trace colour on the wire.

19. In the Engine Bay, disconnect the vehicle battery negative terminal (1).
20. Remove the cover off the fuse block (2).

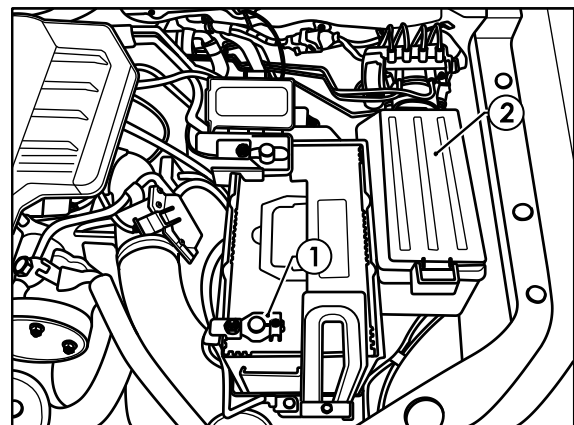

21. Under the vehicle left hand side, connect the vehicle pre-wire connector (1) to the mating connector on the trailer patch (102639-WL).
22. Connect the waterproof ECU (04835) to the ECU connector on the trailer wiring harness.
23. Secure the ECU to the chassis rail (2).

Note: Ensure the module connector is pointing downwards.

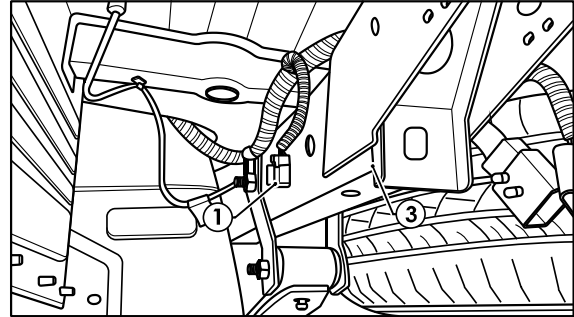

24. For vehicles with reverse sensors, under the vehicle left hand side behind the rear left wheel, locate the vehicle bumper connector (1) attached to the chassis.
25. On the vehicle side, cut the RPA ground (Black) wire (2) and strip, crimp, splice and seal the grey and grey black wires to each side of the black wire.

Note: The wire is thin Black.

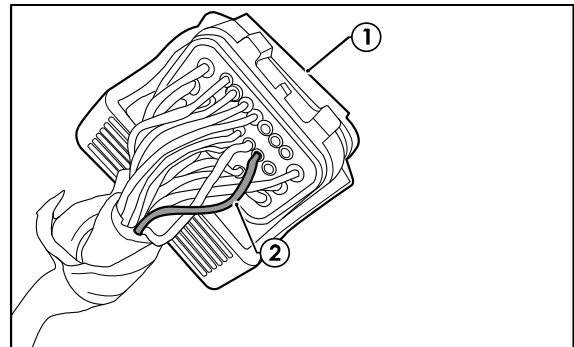

26. Route the power and ground wires along the chassis rail towards the front of the vehicle.
27. Secure the harness to the vehicle chassis rail.

NB: Keep harness routing clear of all sharp edges, moving parts and places of extreme heat.

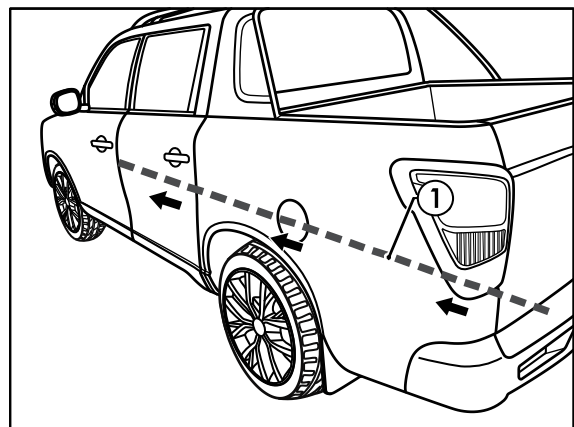

28. In the engine bay, connect the M6 ground wire ring terminal to the vehicle earthing point (1) on the firewall.
29. Connect the M6 orange fused ring terminal to the fuse box positive stud (2).
30. Reconnect the vehicle negative battery terminal. Tie up any excess lengths as required.

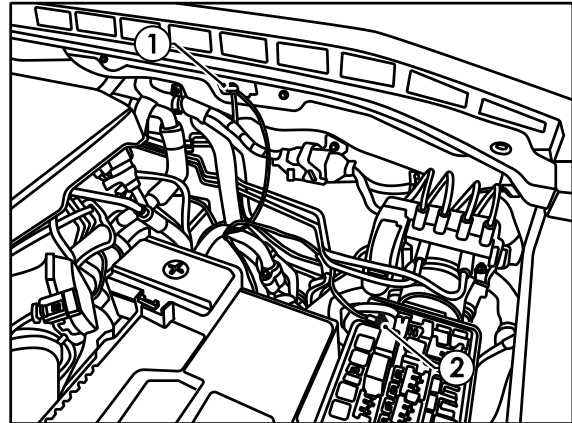

31. At the rear of the vehicle LHS, connect the tail harness (tail length 1200mm) 8-way connector (1) to the trailer patch mating 8-way connector (2).
32. Cut-off, crimp the tail harness GREY and GREY/BLACK wires (3) to the trailer patch matching GREY and GREY/BLACK wires (4).

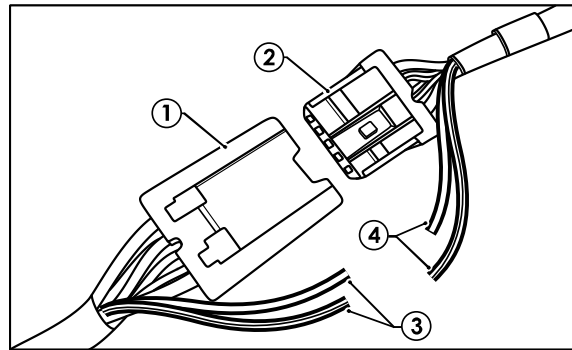

33. Test the trailer patch function using a light board or multi-meter.
34. Secure all harness using cable ties (not supplied).
35. Re-fit all removed parts and secure all fasteners, ensuring there are no squeaks or rattles.
36. Place the fitting instructions in the glove box after fitment.



CUSTOMER INFORMATION

PLACE THESE INSTRUCTIONS IN THE
VEHICLE'S GLOVEBOX AFTER INSTALLATION

**THANK YOU FOR PURCHASING TRAILBOSS. WITH CORRECT MAINTENANCE AND CARE
THIS PRODUCT WILL PROVIDE A LIFETIME OF TROUBLE-FREE OPERATION.**

TOWBAR MAINTENANCE AND CARE:

1. Trailboss recommend that the towbar LUG or TBM (Trailer Ball Mount) Pull Pin and R-clip are removed and stored when not in use. Removal of LUG or TBM (Trailer Ball Mount) is advisable when not in use to assist with any of the following.
 - Ensure rear number plate is not obscured.
 - Allow maximum available departure angle and prevent any potential interference.
 - Prevent possible interference with vehicles reverse sensors or camera detecting a tow ball mount as an obstruction during reversing.
 - Removes towball mount as an obstruction for when moving around the rear of the vehicle.
2. Trailboss recommends routine inspection of your towbar to ensure trouble free towing.
 - Bolt security and tension should be regularly inspected and checked for correct tension. Replace any worn or defective parts with suitable grade & class fasteners. Inspection should be requested to coincide with vehicle major services.
3. It is the owner's responsibility to ensure towing and down ball weight capacities of the towing vehicle are not exceeded.
 - Towing and down ball weights allowable may differ according to model variations. Please refer to owner's manual or vehicle dealer to confirm exact rating for your vehicle model variant.
 - It is not uncommon for the vehicle tow rating to differ from the towbar rating. When this occurs, the lesser rating must be adhered to.
 - For vehicles fitted with enhanced vehicle functions that may be altered/changed when towing i.e Trailer sway mitigation, blind spot detection, adaptive cruise control etc. Please consult owner's manual to understand changes enabled when towing and after towing.

WARRANTY INFORMATION:

Trailboss Towbars are covered by a Lifetime Warranty.

Our goods come with guarantees that cannot be excluded under the Australian Consumer Law. You are entitled to a replacement or refund for a major failure and for compensation for any other reasonably foreseeable loss or damage. You are also entitled to have the goods repaired or replaced if the goods fail to be of acceptable quality and the failure does not amount to a major failure.

For further details please contact customer service on 1800 812 017.

PRO SERIES SILENT ANTI-RATTLE HITCH PIN

Your Trailboss towbar is equipped with a Pro Series Silent Anti-Rattle Hitch Pin technology to help reduce towbar tongue rattle in most driving conditions. Please ensure below instructions are understood and routine maintenance is carried out to ensure best towing experience.

Regularly inspect for wear and check the tightness of the Silent Anti-Rattle Hitch Pin. Follow instructions below to re-tighten the nut as necessary when movement and noise in the tow ball mount is noted.

- Before towing, ensure R-Clip is properly installed and hitch pin nut is installed and tensioned. Replacement parts are available from your Pro Series Distributor.

TOWBALL MOUNT REMOVAL/INSTALLATION

STEP 1

Insert Trailer Ball Mount (TBM) (a) into towbar hitchbox (b), aligning hole in TBM shank (c) with hole in hitchbox (d) (Fig. 1)

STEP 2

Insert Silent Anti-Rattle Hitch Pin (e) through hole in hitchbox and hole in TBM shank (g); ensure the locators are inserted into the notches in the hitchbox (Fig. 2)

STEP 3

Screw Silent Anti-Rattle Hitch Pin Nut (f) onto Smart Pin (g); tighten Smart Pin Nut until finger tight, ensuring TBM is restrained from up and down movement.

STEP 4

Tighten Silent Anti-Rattle Hitch Pin Nut by turning nut a further 1/8th of a turn in the clockwise direction using a 24mm spanner (Fig. 4).

STEP 5

Install Silent Anti-Rattle Hitch Pin R-Clip through the hole that provides best clearance or easiest access. (Fig. 5)

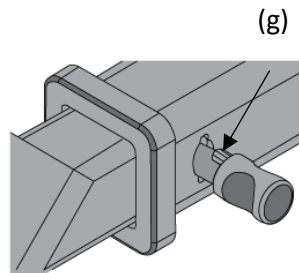
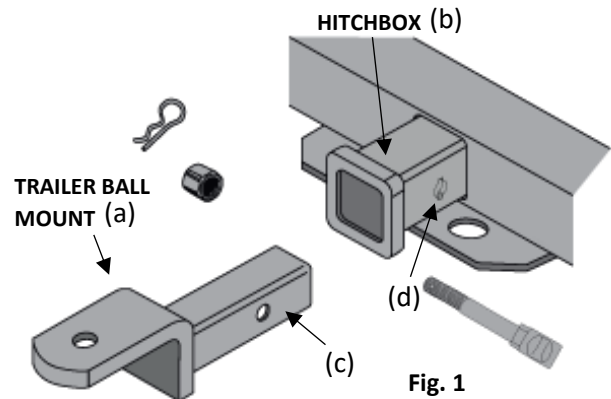

Fig. 2

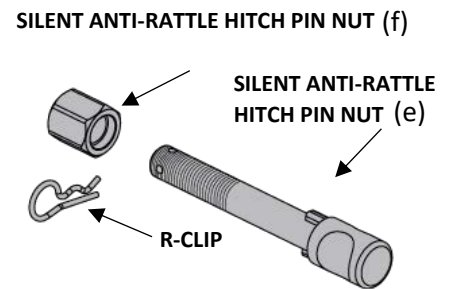

Fig. 3

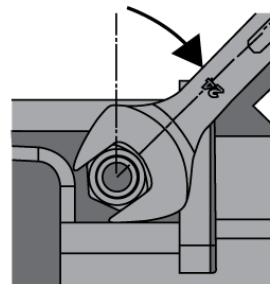

Fig. 4

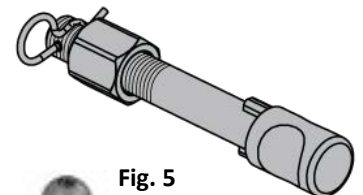

Fig. 5

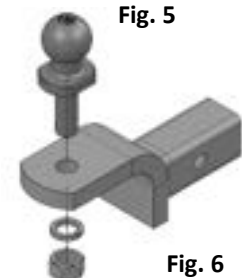

Fig. 6