

TRAILBOSS

Towbar Fitting Instructions
To Suit VOLVO XC90 07/03- ON
Part Number QTVO003L
Rating 2250Kg
Ball Weight 225Kg

1. Ensure all hardware items have been included.
2. Remove spare wheel.
3. Remove and discard towing eye from driver's side.
4. Remove rear most exhaust mounting bracket from sub-frame on the driver side (In newer model, remove the bracket from the passenger side as well).
5. Remove exhaust from rubber near diff, and let it hang.
6. Cut bumper as per diagrams.
7. Fit towbar into position over exhaust first then line up with captive nuts in chassis rails.
8. Fit bolts supplied as per diagram making sure towbar is square to bumper cut, tighten to torque listing (In newer models, discard the rearmost bolt on the driver side, use it on the older models only).
9. Exhaust hanger brackets to be refit with towbar.
10. Refit spare wheel.
11. Towbar rating sticker to be conspicuously located on the inside rear end of the driver's door. (See diagram below)

RECOMMENDED ASSEMBLY TORQUE LISTING

<u>Diameter</u>	<u>Grade 8.8 Bolt</u>
	Nm
M6	9.5
M8	21.7
M10	43.4
M12	77.3
M14	121.0
M16	189.8

FOR TOWING PURPOSES ONLY
For towing capacity details please refer to vehicle owners manual or to the manufacturer. Overloading can void your warranties

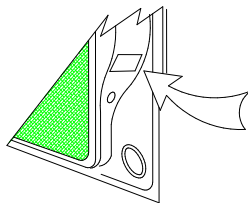

Position Load Rating
Label inside Driver's side
door here

TRAILBOSS

Towbar Fitting Instructions
To Suit VOLVO XC90 07/03- ON
Part Number QTVO003L
Rating 2250Kg
Ball Weight 225Kg



Bumper cut diagram 1, use fins on bumper as a guide.



Bumper cut diagram 2. 75mm to be measured around the outside of the bumper

TRAILBOSS

Towbar Fitting Instructions
To Suit VOLVO XC90 07/03- ON
Part Number QTVO003L
Rating 2250Kg
Ball Weight 225Kg

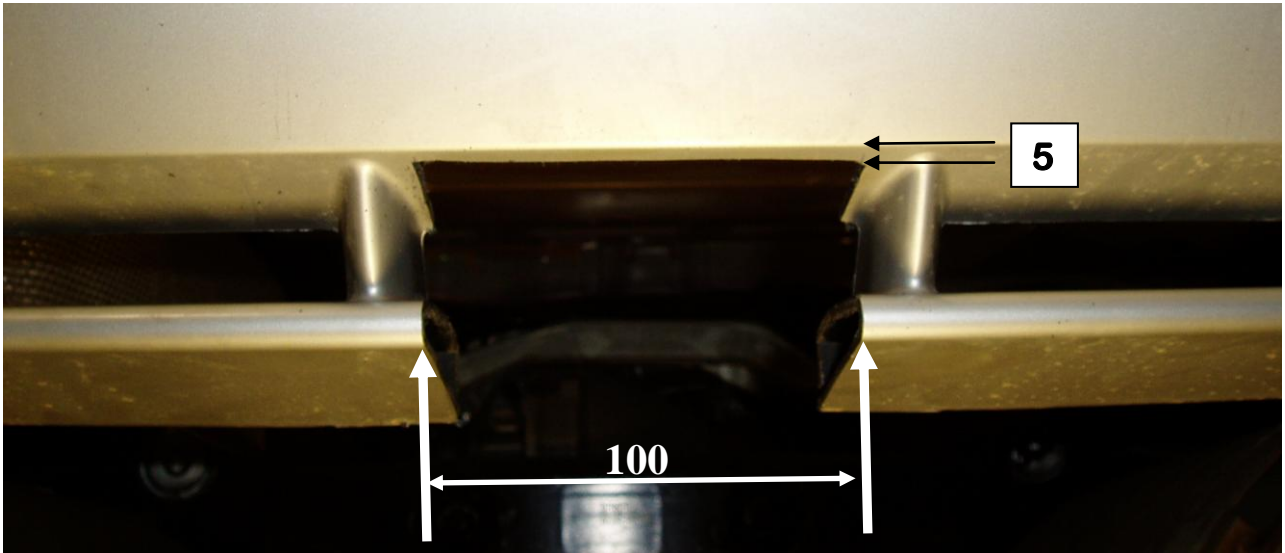

Bumper cut diagram 3, R Design model

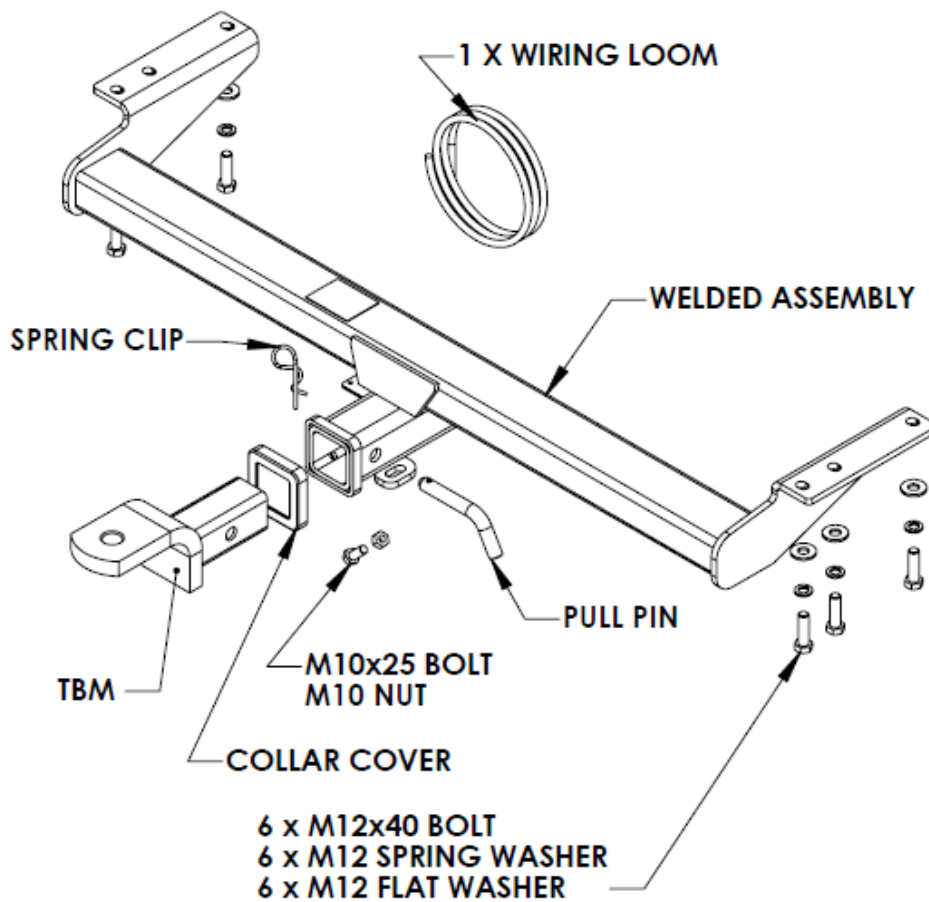



Wiring Loom Fitting Instructions
To Suit Volvo XC90
Part Number 100150-WL

Wiring Loom Installation Instructions

Volvo XC90
Part No: 100150-WL

Tail Harness Length Required: 1200mm
ECU Required: 04826
RPA Override Switch Part No: 04848 (If Fitted)

Wiring Loom Installation Time: Approx 30 Mins

TRAILBOSS

Wiring Loom Fitting Instructions To Suit Volvo XC90 Part Number 100150-WL

1. Remove all the required trims to gain access to the LHS and RHS tail light connectors.
2. Remove the battery support bracket and then remove the battery cover and the air compressor.
3. On the RHS of the battery compartment, carefully drill a Ø31mm hole into the indicated position.



4. File down any rough edges and spray on rust inhibitor around the hole in the rear of the luggage compartment and towards the rear RHS quarter of the vehicle.
5. Underneath the rear of the vehicle, mount the Tail Harness (tail length 1200mm) socket to the towbar mounting bracket using M4 fasteners (not supplied).
6. Route the tail harness across to the drilled hole ensuring to keep the harness away from the exhaust pipe. Adjust the tail harness grommet to the desired position ensuring that the tail harness grommet is seated correctly into place. Secure grommet with a cable tie (not supplied).
7. In the luggage compartment, retrieve the tail harness from the drilled hole.
8. At the LHS tail light cavity area, patch the Trailer Harness (P/No: 100150-WL) connectors in between the tail light connectors.
9. Connect the trailer patch harness ECU connector to the ECU. Secure the trailer patch harness ring terminal to the power point on the fuse panel. Secure the ECU to the vehicle harness using cable ties (not supplied) or using double sided tape (not supplied) onto the fuse panel support sheet metal area.
10. Route the trailer patch harness underneath the trim and foam trays, along the rear of the vehicle towards the RHS tail light cavity area. Connect the tail harness connector to the trailer patch harness connector.
11. On the RHS, patch the Trailer Harness connectors in between the tail light connectors.
12. On the outside, secure the harness to the towbar using cable ties (not supplied).
13. Test the Trailer socket using a light board or multi-meter.
14. Secure the all harnesses using cables ties (not supplied).
15. Refit all removed parts and secure all fasteners.
16. Place instructions in glove box after fitment.