

TRAILBOSS

Towbar Fitting Instructions To Suit Volvo V60 2011-on Part Number QTVO006L Rating 1800/150 kg

WARNING:

1. Do not, drill, cut, weld or otherwise modify the tow bar.
2. If you are using electric welding on a motor vehicle, **always** check that the vehicle is not equipped with electronic engine or instrument management equipment. Failure to do so could **destroy** any onboard computers. If in doubt, check with the vehicle's manufacturer.
3. The high tensile fasteners supplied with this product were used to achieve the specified rating. If replacement is required ensure that fasteners of the same rating & quality are used. Contact an authorised **Trailboss** dealer if further information is required.

General:

1. Ensure all hardware items have been included refer to assembly diagram.
2. It is recommended that the instructions are read through and completely understood before making any attempt to fit this product.
3. Be wary of any changes to vehicle designs or other accessories that may conflict with the installation of this product.
4. Before drilling ensure that the area is clear of fuel, electrical & other components.
5. All holes drilled into the body panels shall have all burrs & swarf removed then coated with a suitable rust preventative paint.
6. For vehicles that require the bumper to be cut. Ensure cut out area is in correct position on the vehicle prior to cutting the bumper.
7. The high tensile fasteners supplied with this product were used to achieve the specified rating. If replacement is required ensure that fasteners of the same rating & quality are used. Contact an authorized **Trailboss** dealer if further information is required.
8. Ensure that all hardware is fastened to torque list below check fasteners on regular basis.
9. Tow bar load rating sticker provided with this product shall be conspicuously located on inside rear end of the driver's door. **(See diagram below).**
10. Trailboss recommends that you check your tow ball to ensure that it complies with the Australian standards **AS 4177.2.**
11. **PLEASE NOTE:** It is advised to remove your lug or tbn when not actually towing so as to produce a clear view of the vehicles registration plate if obscured, and to also provide maximum available departure angle
12. Pull Pin must be fit in down position.

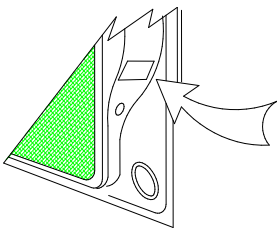

Place load rating sticker
inside driver's door here

FOR TRAILER TOWING PURPOSES ONLY
For towing capacity details please refer to vehicle owner's manual or to the manufacturer. Overloading can void your warranties.

RECOMMENDED ASSEMBLY TORQUE LISTING

Diameter	Grade 8.8 Bolt
M6	9.5 Nm
M8	21.7 Nm
M10	43.4 Nm
M12	77.3Nm
M14	146 Nm
M16	189.8 Nm

Tow bar Maintenance and Care.

Trailboss recommends that bolt torque's, as listed below, are routinely and regularly inspected and checked for correct tension. Replace any worn or defective parts.

We recommended to remove Tow Ball Mounts (TBM's, tongues or lugs) when not being used for any considerable length of time.

So as to avoid injury, when not towing it is suggested that the tongue, Pull Pin and R-clip are removed then stored in a safe, clean and dry place, away from excessive moisture.

Hitch Pull Pins and spring "R" clips are regularly checked for proper installation. Replace any worn or defective parts.

TRAILBOSS

Towbar Fitting Instructions To Suit Volvo V60 2011-on Part Number QTVO006L Rating 1800/150 kg

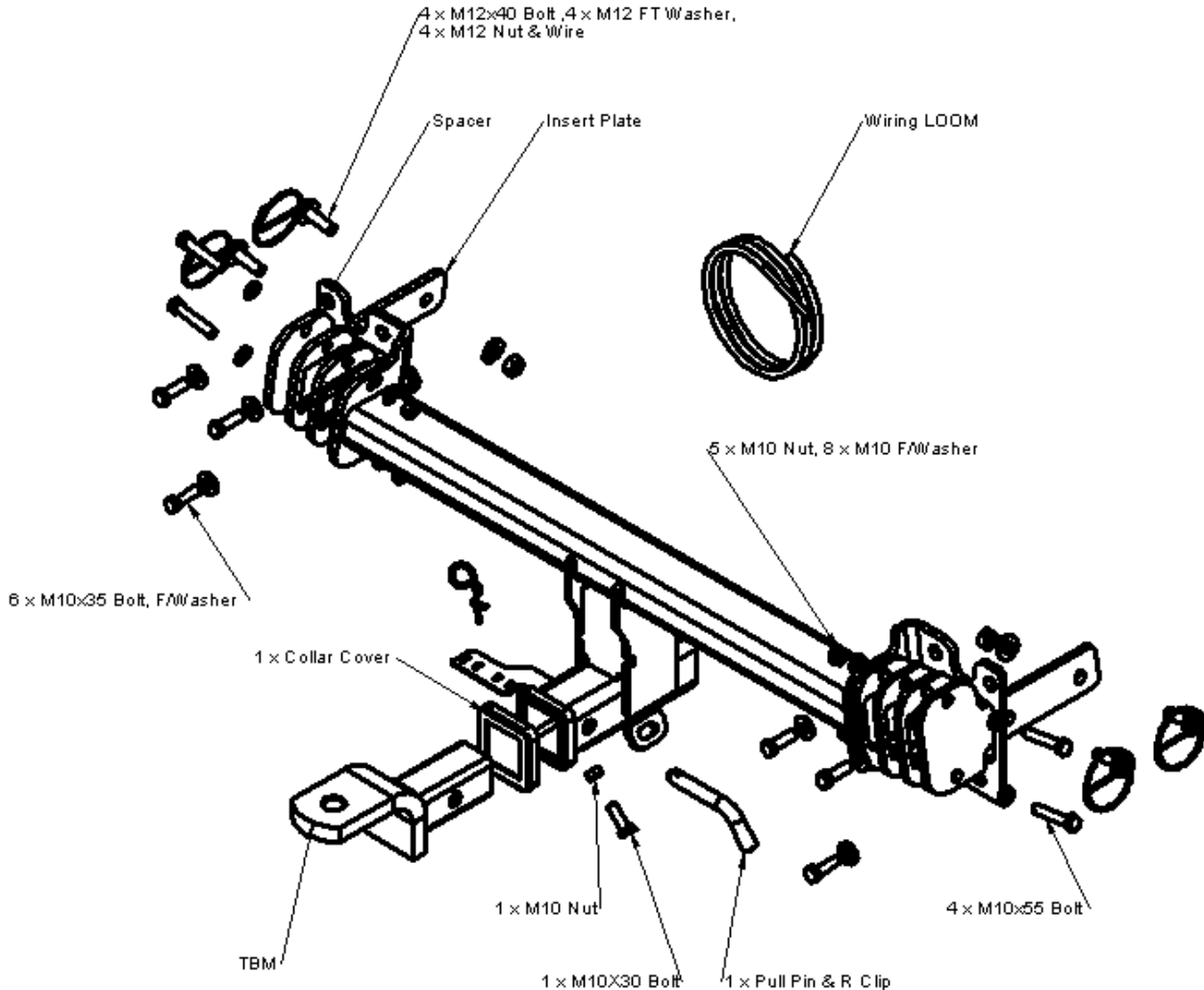

1. Remove rear bumper according to the workshop manual. **Note:** Remove any electrical connections to the bumper before completely removing from vehicle.
2. Remove 3 x Bolts from each side to remove rear impact beam. Lower exhaust by removing the rear most bolts on the side. Move heat shield to allow access to chassis rails.
3. Loosely secure Towbar to vehicle using M10 x 35 Bolts and M10 x 25.4 Flat Washers.
4. Attach Insert Plates and 3 x Spacers to each side of Towbar using M10 x 55 Bolts, M10 x 21 Flat Washers and M10 Nuts. Uncoil the wire on the M12 Bolt/Wire assembly and insert in to chassis rail and secure Insert Plates. Use M12 Flat Washers and M12 Nuts from the outside of the chassis rails.
5. Ensure Towbar is square to vehicle and tighten bolts to the specified torque setting. Refer to table on page 1.
6. Cut rear bumper / skid plate as shown on Page 3. Attach Bumper Trim on to cut edge of bumper.
7. Adjust heat shield to its original position. Ensure that there is sufficient clearance between the Towbar and the heat shield. Lift exhaust system in to place and tighten bolts.
8. Re-fit rear bumper to vehicle in reverse order of removal.

TRAILBOSS

Towbar Fitting Instructions
To Suit Volvo V60 2011-on
Part Number QTVO006L
Rating 1800/150 kg

Skid Plate Cut - out

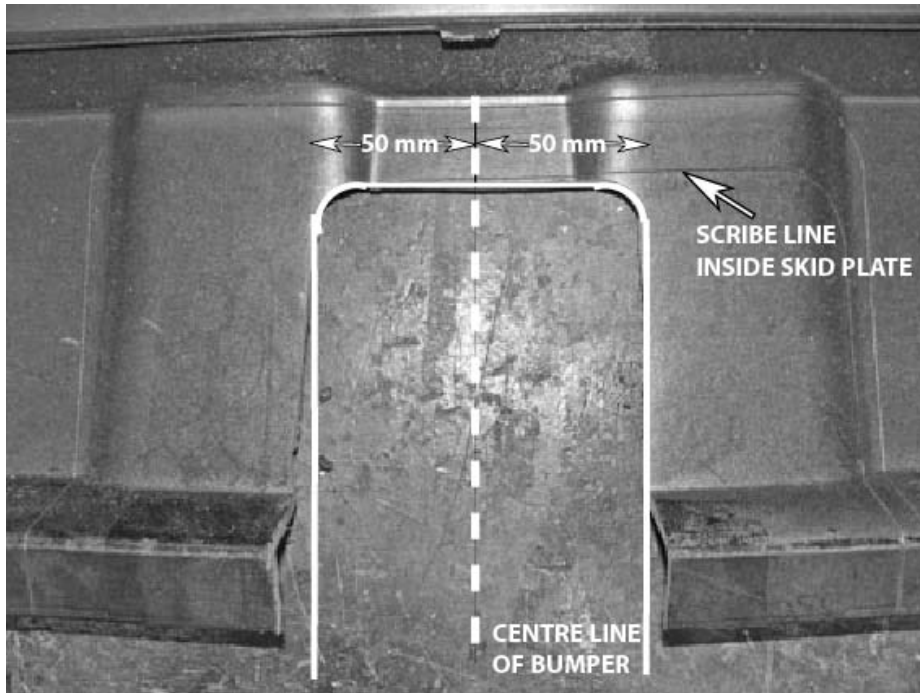

Bumper Cut-out

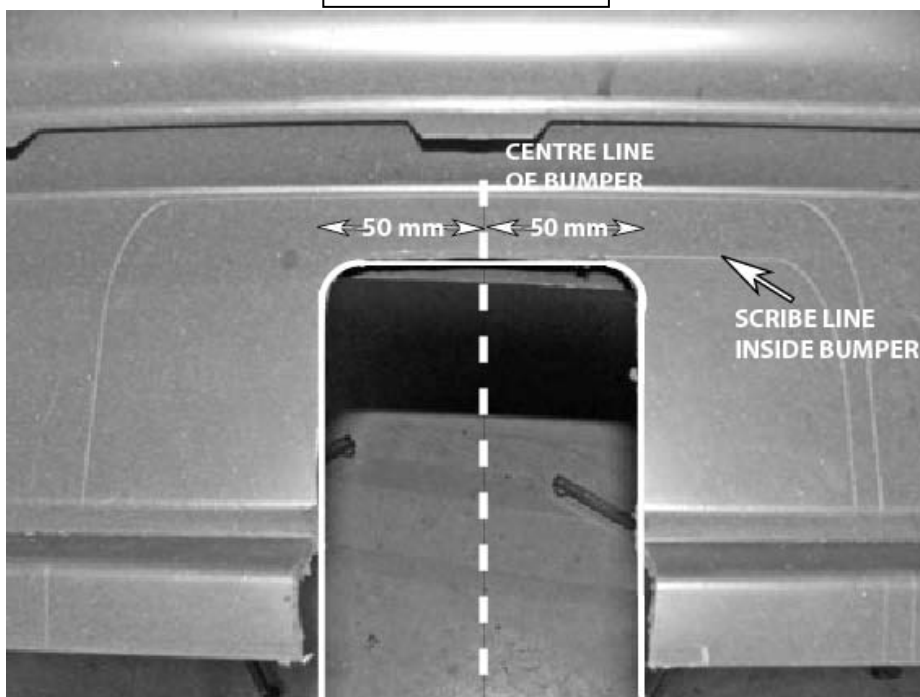



Wiring Loom Fitting Instructions
To Volvo V60
Part Number 100717-WL

Wiring Loom Installation Instructions

**Volvo V60
Part No: 100717-WL**

**Tail Harness Length Required: 1200mm
RPA Override Switch Part No: 04848 (If Fitted)**

Wiring Loom Installation Time: Approx 30 Mins



Wiring Loom Fitting Instructions
To Volvo V60
Part Number 100717-WL

1. In the luggage compartment, remove the parcel shelf.
2. Remove floor cover carpet.
3. Remove the storage tub compartment.
4. Underneath the rear trim; remove the rear section of the storage compartment.
5. Underneath the rear trim, drill a Ø30mm hole next to the existing vehicle grommet.
6. File any rough or sharp edges and spray on the rust inhibitor.
7. In the LHS of the luggage compartment, remove the access panel.

Repeat step for RHS.

8. On the LHS of the luggage compartment, using a guide wire (not supplied), route the 6-way trailer patch underneath the metal frame towards the LHS 6-way taillight connectors.
9. On the LHS of the luggage compartment, disconnect the vehicle LHS 6-way connector and patch in the 6-way trailer patch connector in between.
10. In the LHS luggage compartment, secure the trailer patch ground ring terminal to the vehicle grounding point using the existing fasteners.
11. Insert the add-a-fuse by first removing the 30amp fuse and inserting it into the lower slot and insert the 20amp supplied fuse into the upper slot.
12. Connect the 1-way connector trailer patch into the add-a-fuse 1-way connector.
13. Store the fuse cover in the tool tray.
14. Connect the trailer patch 12-way female ECU connector to the ECU (P/No: 04826).
15. Secure the ECU using double sided tape.
16. Route the trailer patch towards the RHS of the luggage compartment.
17. On the RHS of the luggage compartment, using a guide wire (not supplied) route the 6-way trailer patch underneath the metal frame towards the 6-way taillight connectors.
18. Disconnect the vehicle 6-way taillight connector and patch in the 6-way trailer patch connector in between.
19. Mount the trailer socket to the towbar mounting bracket using M4 fasteners (not supplied)
20. Route the tail harness (tail length 1200mm) along the towbar and through the previously drilled out hole.
21. Slide the grommet into position and secure it in place using a cable tie (not supplied).



Wiring Loom Fitting Instructions
To Volvo V60
Part Number 100717-WL

22. Connect the trailer harness 8-way connector to the tail harness mating connector.
23. Test the Trailer Harness function using a light board or multimeter.
24. Secure all harness using cable ties (not supplied).
25. Re-fit all removed parts and secure all fasteners, ensuring there are no squeaks or rattles.
26. Place the instructions in the glove box after fitment.