

TRAILBOSS

Towbar Fitting Instructions To Suit **VOLKSWAGEN CADDY 4** Part Number **QTVW215L** Rating **1500/100 kg**

PLACE THESE INSTRUCTIONS IN THE VEHICLE'S GLOVEBOX AFTER INSTALLATION IS COMPLETED

WARNING:

1. Do not, drill, cut, weld or otherwise modify the tow bar.
2. If you are using electric welding on a motor vehicle, **always** check that the vehicle is not equipped with electronic engine or instrument management equipment. Failure to do so could **destroy** any onboard computers. If in doubt, check with the vehicle's manufacturer.
3. The high tensile fasteners supplied with this product were used to achieve the specified rating. If replacement is required ensure that fasteners of the same rating & quality are used. Contact an authorised **Trailboss** dealer if further information is required.
4. If TBM is used in inverted position tow ball may make contact with rear tailgate when lowered, which could cause damage.

General:

1. Ensure all hardware items have been included refer to assembly diagram.
2. It is recommended that the instructions are read through and completely understood before making any attempt to fit this product.
3. Be wary of any changes to vehicle designs or other accessories that may conflict with the installation of this product.
4. Before drilling ensure that the area is clear of fuel, electrical & other components.
5. All holes drilled into the body panels shall have all burrs & swarf removed then coated with a suitable rust preventative paint.
6. For vehicles that require the bumper to be cut. Ensure cut out area is in correct position on the vehicle prior to cutting the bumper.
7. The high tensile fasteners supplied with this product were used to achieve the specified rating. If replacement is required ensure that fasteners of the same rating & quality are used. Contact an authorized **Trailboss** dealer if further information is required.
8. Tow bar load rating sticker provided with this product shall be conspicuously located on inside rear end of the driver's door. **(See diagram below).**
9. Trailboss recommends that you check your tow ball to ensure that it complies with the Australian standards **AS 4177.2.**
10. **PLEASE NOTE:** It is advised to remove your LUG or TBM when not actually towing so as to produce a clear view of the vehicles registration plate if obscured, and to also provide maximum available departure angle

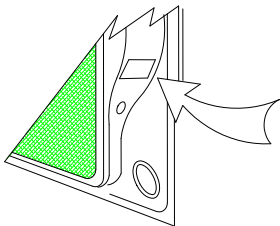

Place load rating sticker
inside driver's door here

FOR TRAILER TOWING PURPOSES ONLY
For towing capacity details please refer to vehicle owner's manual or to the manufacturer. Overloading can void your warranties.

RECOMMENDED ASSEMBLY TORQUE LISTING

<u>Diameter</u>	<u>Grade 8.8 Bolt</u>
M6	9.5 Nm
M8	21.7 Nm
M10	43.4 Nm
M12	77.3Nm
M14	146 Nm
M16	189.8 Nm

Tow bar Maintenance and Care.

Trailboss recommends that bolt torque's, as listed below, are routinely and regularly inspected and checked for correct tension. Replace any worn or defective parts.

We recommended to remove Tow Ball Mounts (TBM's, tongues or lugs) when not being used for any considerable length of time.

So as to avoid injury, when not towing it is suggested that the tongue, Pull Pin and R-clip are removed then stored in a safe, clean and dry place, away from excessive moisture.

Hitch Pull Pins and spring "R" clips are regularly checked for proper installation. Replace any worn or defective parts.

Cequent Customer Service

Ph: 1800 812 017 Fax: 03 9898 3299

Email: info@cequent.com.au

Post: PO Box 4050, Dandenong South VIC 3175

TRAILBOSS

Towbar Fitting Instructions
To Suit **VOLKSWAGEN CADDY 4**
Part Number **QTVW215L**
Rating **1500/100 kg**

PLACE THESE INSTRUCTIONS IN THE VEHICLE'S GLOVEBOX AFTER INSTALLATION IS COMPLETED

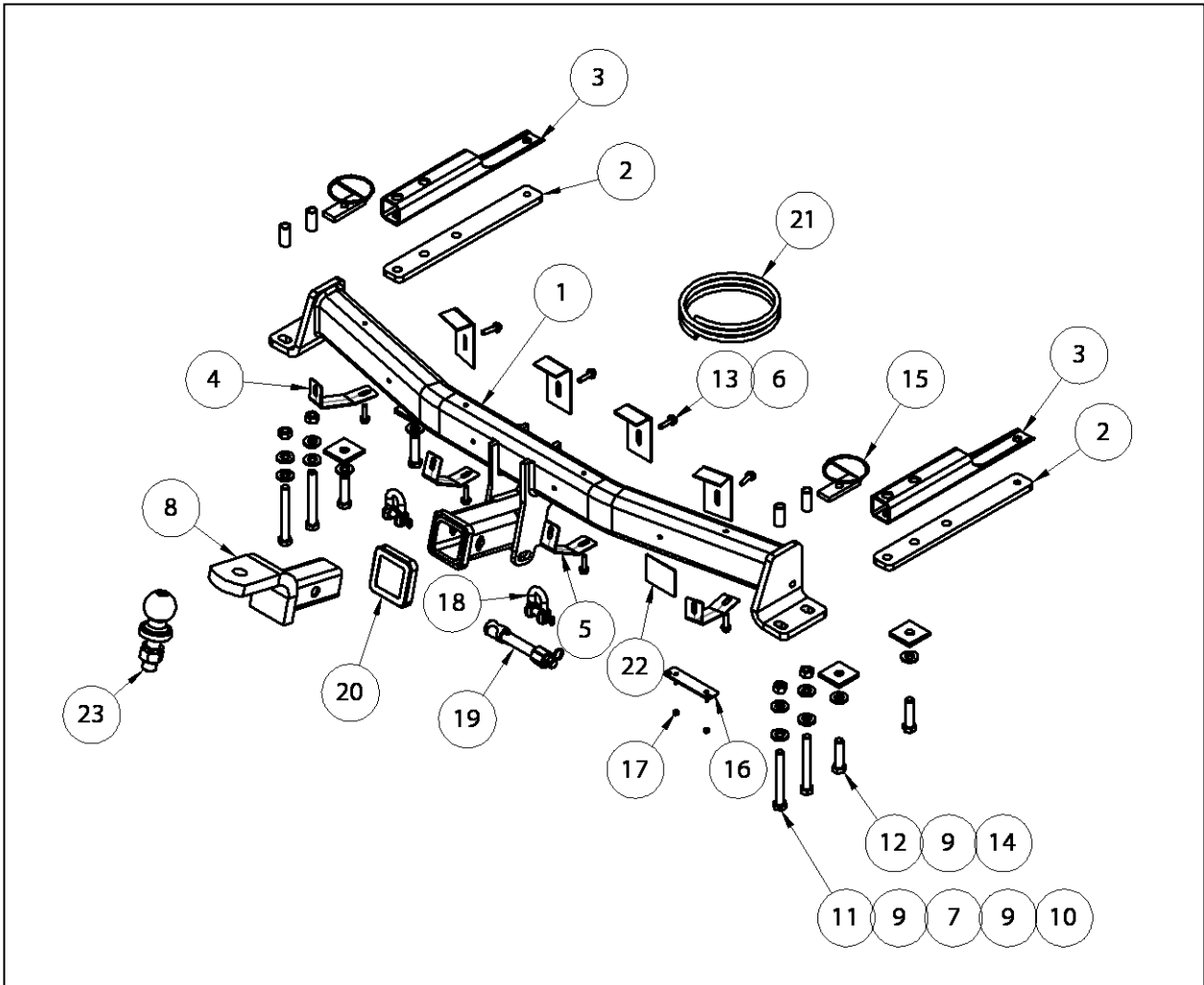

Cequent Customer Service
Ph: 1800 812 017 Fax: 03 9898 3299
Email: info@cequent.com.au
Post: PO Box 4050, Dandenong South VIC 3175



Towbar Fitting Instructions
To Suit **VOLKSWAGEN CADDY 4**
Part Number **QTVW215L**
Rating **1500/100 kg**

PLACE THESE INSTRUCTIONS IN THE VEHICLE'S GLOVEBOX AFTER INSTALLATION IS COMPLETED

ITEM NO.	DESCRIPTION	QTY.
1	WELDED ASSEMBLY	1
2	TUBE SUPPORT	2
3	TUBE INSERT	2
4	BUMPER TAB LEFT	2
5	BUMPER TAB RIGHT	2
6	TOP HAT	4
7	S/TUBE 35mm 16x1.6	4
8	TRAILER BALL MOUNT	1
9	WASHER FLAT 1/2"x1/8"x1/8"	12
10	M12x1.25 HEX NUT PC8	4
11	BOLT HEX HD M12-1.25x100mm GR10.9 Z/P	4
12	M12x50 1.25P BOLT	4
13	TEK SCREW 14-20 HEX HD 22mm	8
14	45x6x45 ø13 LOOSE PLATE	4
15	FTTING PLATE TAPED M12x1.25	2
16	PLUG BRACKET	1
17	NUT NYLOC M4-0.7 Z/P	2
18	10mm "D" SHACKLE	2
19	SILENT HITCH PIN-SILVER	1
20	HITCH BOX COLLAR COVER	1
21	VOLKSWAGEN CADDY MAXI 2009 TRAI	1
22	ACRYLIC COMPLIANCE PLATE	1
23	50mm TOWBALL	1

Cequent Customer Service
Ph: 1800 812 017 Fax: 03 9898 3299
Email: info@cequent.com.au
Post: PO Box 4050, Dandenong South VIC 3175

TRAILBOSS

Towbar Fitting Instructions
To Suit **VOLKSWAGEN CADDY 4**
Part Number **QTVW215L**
Rating **1500/100 kg**

PLACE THESE INSTRUCTIONS IN THE VEHICLE'S GLOVEBOX AFTER INSTALLATION IS COMPLETED

1. Remove 2 x T25 Torx Bolts from each wheel arch.



2. Remove Nuts securing the impact beam to the back panel of vehicle. Passenger side has 3, driver side has 4 (1 is located behind rubber grommet on the outside of Spring Hanger).



3. Disconnect the harness from the bumper sensors and remove bumper along with the impact beam.



Cequent Customer Service
Ph: 1800 812 017 Fax: 03 9898 3299
Email: info@cequent.com.au
Post: PO Box 4050, Dandenong South VIC 3175

Towbar Fitting Instructions
To Suit **VOLKSWAGEN CADDY 4**
Part Number **QTVW215L**
Rating **1500/100 kg**

PLACE THESE INSTRUCTIONS IN THE VEHICLE'S GLOVEBOX AFTER INSTALLATION IS COMPLETED

4. Remove the impact beam from Bumper.
4 x T30 torx screws hold the intrusion beam in place.

Retain the torx screws for bumper tabs attachment.

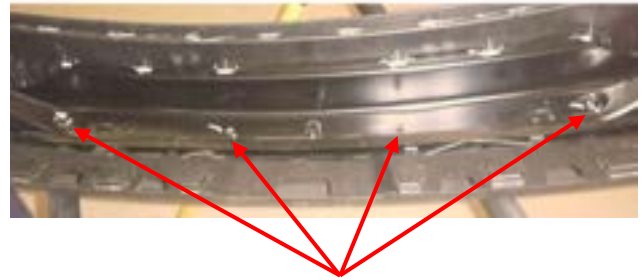

5. Fit side arms.

Slide the Tube Support and the Tube Insert into chassis rail until the two mounting holes on each side arm align with holes on vehicle.

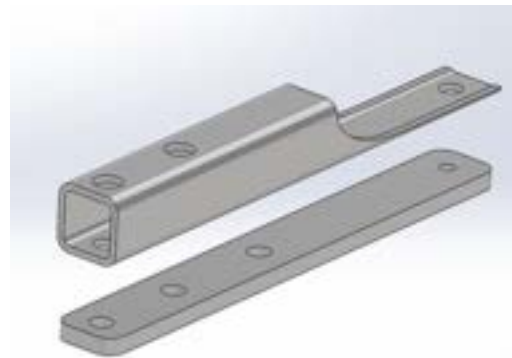

6. Loosely secure using the M12x50 Bolt along with the washer and washer plate for the most forward mounting position (Position 1).

Use the M12x50 Bolt along with the washer and washer plate and the Taped Fitting Plate on Wire to loosely secure the most rearward position (Position 2).

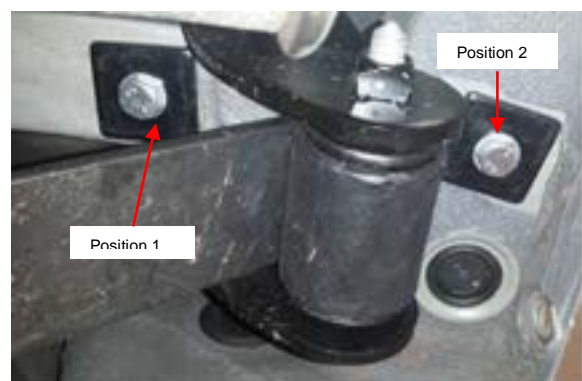

Cequent Customer Service
Ph: 1800 812 017 Fax: 03 9898 3299
Email: info@cequent.com.au
Post: PO Box 4050, Dandenong South VIC 3175

Towbar Fitting Instructions
To Suit **VOLKSWAGEN CADDY 4**
Part Number **QTVW215L**
Rating **1500/100 kg**

PLACE THESE INSTRUCTIONS IN THE VEHICLE'S GLOVEBOX AFTER INSTALLATION IS COMPLETED

7. Loosely secure the top hats to the front of the welded assy using the Tek screws supplied.

The height should be approximately 15mm and 20mm.

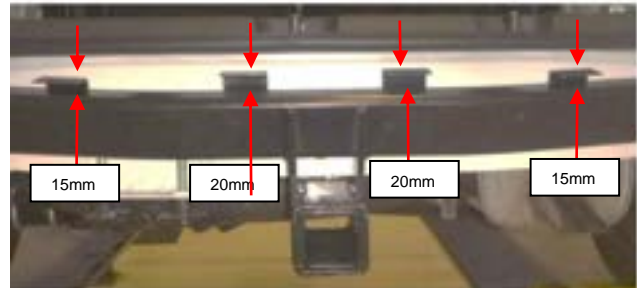

8. Fit Welded assembly

Position the Welded Assembly and loosely secure using the M12x100 bolts, along with 2 washers, spacer tube and nut per bolt for the left and right sides.

Note: The spacer tube is fitted from the top of the Tube insert and the bolt must be fitted with the head down.

Torque all bolts to 120Nm

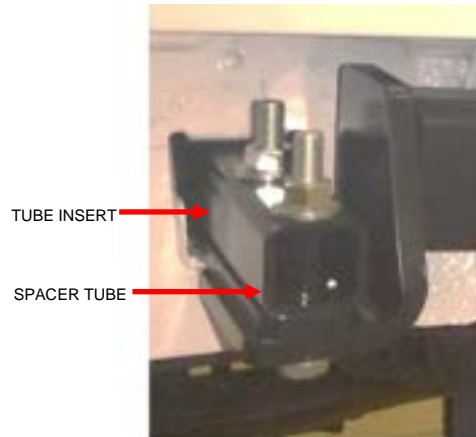

9. Perform Bumper Cut.

Locate the centre of the bumper and mark off a total width of 75mm, the centreline being the midpoint.

On the outer panel of the bumper, measure 80mm upward from the bottom edge of the bumper. Mark out and cut using a saw or similar device, remove all burrs

On the bumper inner panel, open up the existing recess to a width of 75mm and a depth of 55mm, measured from the bottom edge of the bumper.

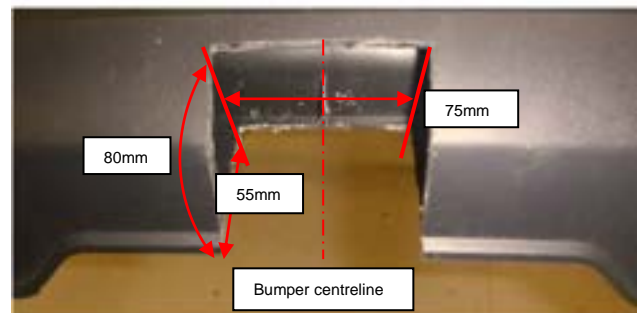

Cequent Customer Service

Ph: 1800 812 017 Fax: 03 9898 3299

Email: info@cequent.com.au

Post: PO Box 4050, Dandenong South VIC 3175

Towbar Fitting Instructions
To Suit **VOLKSWAGEN CADDY 4**
Part Number **QTVW215L**
Rating **1500/100 kg**

PLACE THESE INSTRUCTIONS IN THE VEHICLE'S GLOVEBOX AFTER INSTALLATION IS COMPLETED

10. Inside bumper cuts.

Mark out and cut a hole 38mm wide x 38mm high from the inside panel on the LH and RH side of the bumper panel as indicated. Remove all burrs.

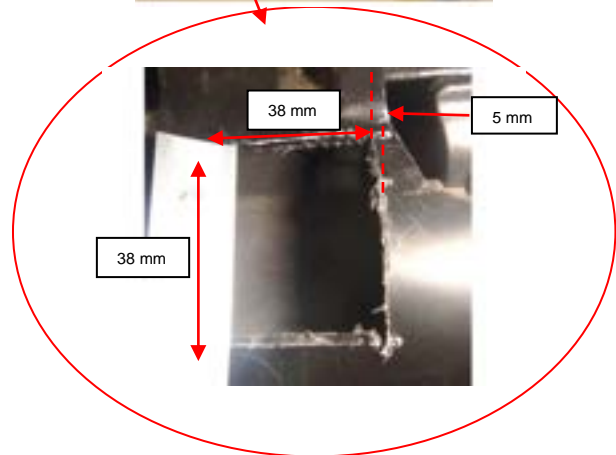
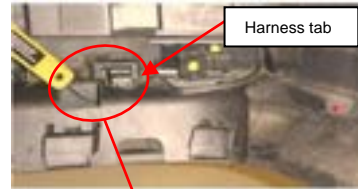

11. Secure the 4 Bumper Tabs to the bumper using the impact beam bumper support locations and the Torx screws.



Cequent Customer Service
Ph: 1800 812 017 Fax: 03 9898 3299
Email: info@cequent.com.au
Post: PO Box 4050, Dandenong South VIC 3175

TRAILBOSS

Towbar Fitting Instructions
To Suit **VOLKSWAGEN CADDY 4**
Part Number **QTVW215L**
Rating **1500/100 kg**

PLACE THESE INSTRUCTIONS IN THE VEHICLE'S GLOVEBOX AFTER INSTALLATION IS COMPLETED

12. Refit Bumper.

Reconnect the harness to the bumper sensors and fit the bumper to the vehicle. Fit the 2 Torx bolts into the wheel arch on both sides.

Secure the 4 Bumper Tabs to the bottom of the Welded Assembly using the Tek screws.

Make final adjustments, and tightly secure the Top Hats to the welded assembly ensuring they provide adequate support to the bumper.

Discard the impact beam.



Cequent Customer Service

Ph: 1800 812 017 Fax: 03 9898 3299

Email: info@cequent.com.au

Post: PO Box 4050, Dandenong South VIC 3175



Wiring Loom Fitting Instructions
To Suit Volkswagen Caddy 2KN (People Mover and Commercial Van)
Part Number 100278-WL (QTVW215L)

Wiring Loom Installation Instructions

Volkswagen Caddy 2KN
(People Mover and Commercial Van)

Part No: 100278-WL

Tail Harness Length Required: 1800mm

ECU Required: 04836

Power Harness: 04825 (supplied)

Wiring Loom Installation Time: Approx 45 Mins



Wiring Loom Fitting Instructions
To Suit Volkswagen Caddy 2KN (People Mover and Commercial Van)
Part Number 100278-WL (QTVW215L)

All Steps are applicable to both models unless otherwise specified.

Steps 1 to 8 for People Mover variants only. For Commercial Van variants, start at Step 9.

1. In the RHS rear cargo area, remove access panel and car jack.
2. Remove the RHS luggage compartment trim.
3. Remove the RHS speaker/seatbelt surround trim by first removing the required fasteners and then disconnecting the speaker connectors. **Repeat Steps 2 and 3 for the LHS trims.**
4. Inside the vehicle cabin, dislodge the RHS 'B' pillar trim and then remove the lower door sill trim.
5. On the RHS of the driver's side, remove the side dash panel and the fuse cover panel.
6. Underneath the driver's lower dash, remove the bonnet release handle and the one scrivet from the front end of the driver's door sill trim.
7. Remove the fastener located on driver's dash lower RHS (above the front face of the kick trim upper area) and then remove the driver's door sill trim.
8. At the rear of the vehicle, remove the two cargo hooks from the luggage compartment rear trim and then remove the rear trim. **People Mover variants, go to Step 12.**

Steps 9 to 11 for Commercial Van variants only:

9. In the cargo area RHS, remove the car jack and remove the RHS panel by removing all the required scrivets.
10. Remove the 'B' pillar lower trim.
11. Remove the LHS panel by removing all the required scrivets.

Steps 12 to 17 applicable to both People Mover and Commercial Variants:

12. On vehicle exterior RHS rear quarter, remove the air vent. **Note: Removal of air vent allows easy access for drilling and routing the tail harness. If required, remove the rear intrusion bar according to the towbar fitting instructions.**
13. In the vent cavity area, locate the Ø40mm vehicle grommet and drill a Ø30mm hole into the centre of the grommet.
14. Locate the RHS main vehicle harness section running near the RHS cavity.

Wiring Loom Fitting Instructions To Suit Volkswagen Caddy 2KN (People Mover and Commercial Van) Part Number 100278-WL (QTVW215L)

15. Following the table below, connect the trailer patch (P/No: 100278-WL) ezy-taps (1) to the corresponding vehicle wires (2), then connect the trailer patch terminal (3) to the ezy-taps (1).

Function	Trailer Patch	Vehicle Connector
R.IND	GREEN / BLACK	BLACK / GREEN
TAIL	BROWN / BLACK	GREY / RED
BRAKES	RED / BLACK	RED / BLACK
REVERSE	BLACK / WHITE	BLACK / BLUE

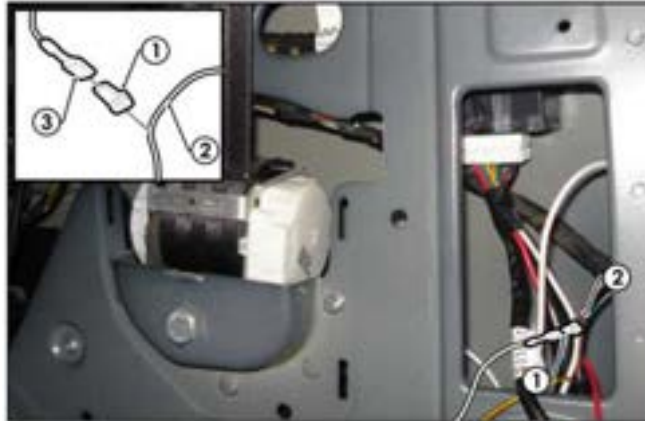

16. Connect the trailer patch connector (1) to the ECU (P/No: 04836) (2). Remove the backing from the back of the ECU and mount the ECU (2) onto a suitable location at the RHS cavity sheet metal area. **Ensure ECU connector (1) is mounted with the connector pointing downwards.**

17. In the RHS panel cavity, secure the trailer patch ground ring terminal (3) to the vehicle grounding location (4).



Steps 18 to 20 applicable to People Mover variants. Go to Step 21 for Commercial Van variants.

18. Along the rear luggage compartment trim, route the trailer harness (P/No: 100278-WL) from the RHS towards the LHS of the luggage compartment.

19. On the LHS of the luggage compartment, following the table below, connect the ezy-tap to the vehicle's existing wiring harness.

Function	Trailer Patch	Vehicle Connector
L.IND	YELLOW / BLACK	BLACK / WHITE
REVERSE	BLACK / WHITE	BLACK / BLUE

Wiring Loom Fitting Instructions To Suit Volkswagen Caddy 2KN (People Mover and Commercial Van) Part Number 100278-WL (QTVW215L)

20. Connect the trailer harness terminals to the corresponding ezy-taps. **Go to Step 25.**
21. Route a long length of guide wire down the LHS rear pillar cavity and secure the trailer patch LHS branch wires onto the guide wire using tape.
22. Retrieve the trailer patch LHS branch from the upper cavity opening. **Undo the tape from the trailer patch harness after routing.**
23. Repeat similar guide wire techniques to continue routing the trailer patch LHS branch (1) through the cargo door cavity and down to the LHS tail light cavity and towards the main vehicle harness area.
24. Following the table below, connect the ezy-taps (2) to the corresponding vehicle wires (3), then connect the trailer patch terminals (4) to the ezy-taps (2).

Function	Trailer Patch	Vehicle Connector
L.IND	YELLOW / BLACK	BLACK / WHITE
REVERSE	BLACK / WHITE	BLACK / BLUE

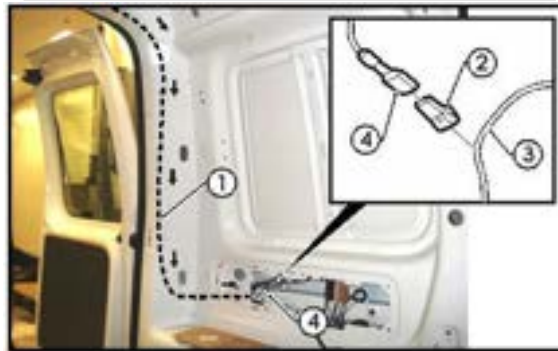

25. At the rear exterior of the vehicle, mount the tail harness socket to the towbar mounting bracket using M4 fasteners (not supplied).
26. Route the tail harness (tail length: 1800mm) across the RHS and up into the drilled out hole. Adjust the trailer patch harness grommet so that it is seated correctly. **Do not cable tie or seal off the grommet yet.**
27. Connect the tail harness 8-way connector to the trailer patch 8-way mating connector.
28. **For People Mover variant:** On the RHS of the passenger's side, route the power harness through the door sill trim past the 'B' pillar trim, towards the front of the driver's side following the vehicle's main existing harness.
29. **For Commercial Van variants:** Route the harness through the 'B' pillar cavity towards the front of the vehicle.
30. **For People Mover variant:** continue to route the harness under the step trim, towards the kick panel and fuse location.
31. **For Commercial Van variant:** continue to route the harness under the step trim, towards the kick panel and fuse location.

Wiring Loom Fitting Instructions To Suit Volkswagen Caddy 2KN (People Mover and Commercial Van) Part Number 100278-WL (QTVW215L)

Steps 32 to 35 for People Mover variants only. Go to Step 36 for Commercial Van variants:

32. Inside the fuse panel, locate the 25-amp fuse (1) as shown and remove.
33. Insert the previously removed 25-amp fuse (1) into the bottom slot of the add-a-fuse.
34. Plug the add-a-fuse (2) into the previously removed 25 amp fuse slot. **Ensure the add-a-fuse is mounted into the orientation as shown.**
35. Connect the power patch 1-way connector (3) into the add-a-fuse harness mating connector (4).

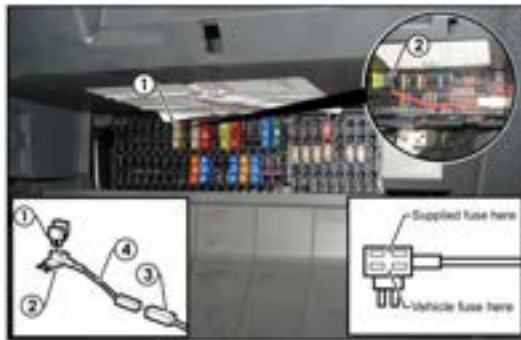

Go to Step 40.

Steps 36 to 39 for People Mover variants only.

36. Inside the fuse panel, locate the 25-amp fuse (1) as shown and remove.
37. Insert the previously removed 25-amp fuse (1) into the bottom slot of the add-a-fuse.
38. Plug the add-a-fuse (2) into the previously removed 25 amp fuse slot. **Ensure the add-a-fuse is mounted into the orientation as shown.**
39. Connect the power patch 1-way connector (3) into the add-a-fuse harness mating connector (4).

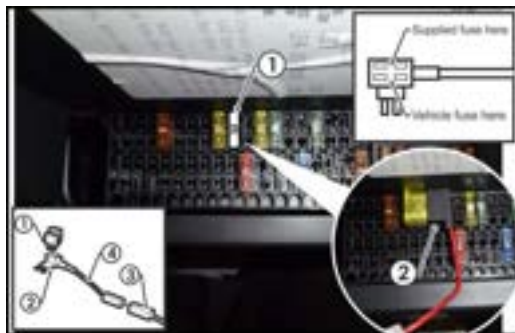

40. Connect the trailer patch to the tail light assemblies and then refit the tail lights.
41. Test the trailer harness function using a light board or multi-meter.
42. Secure all harnesses using cables ties (not supplied).
43. Re-fit all removed parts and secure all fasteners, ensuring there are no squeaks or rattles.
44. Place the instructions in the glove box after fitment.



FITTING INSTRUCTIONS

Silent Anti-Rattle Hitch Pin (PR0001)

• These fitting instructions are supplied to ensure understanding of how the HITCH PIN should be fitted and used correctly.

• Once installed, we recommend **ALL** instructions are kept and placed in the vehicle glove box.

NOTE: Routine maintenance and inspection of the towbar & HITCH PIN is required. Regularly inspect for wear and check the tightness of the Hitch Pin. Follow instructions below to retighten the nut when necessary.

***Do not tow with your vehicle if the R CLIP or the HITCH PIN is loose or missing. Replacement parts are available from your Pro Series Distributor.**

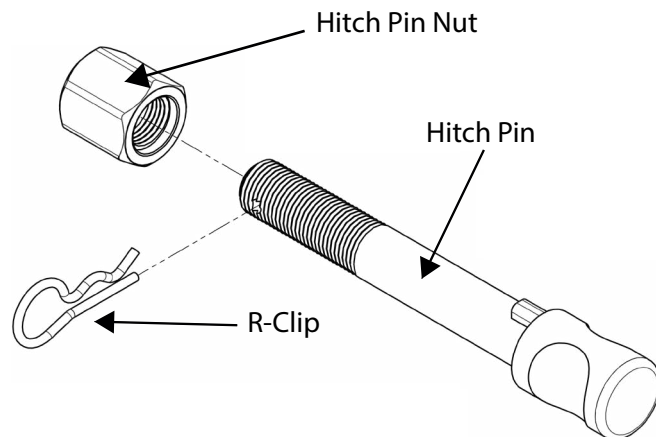

Fig 1. Silent Anti-Rattle Hitch Pin assembly

STEP 1

Insert Trailer Ball Mount (TBM) into towbar HITCHBOX, aligning hole in TBM SHANK with hole in HITCHBOX (Fig 2).

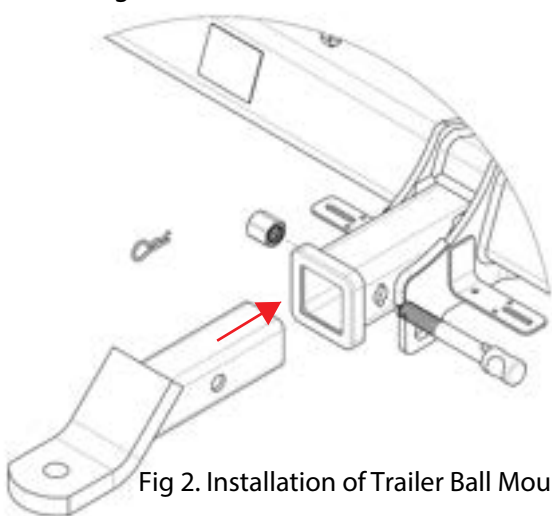

Fig 2. Installation of Trailer Ball Mount

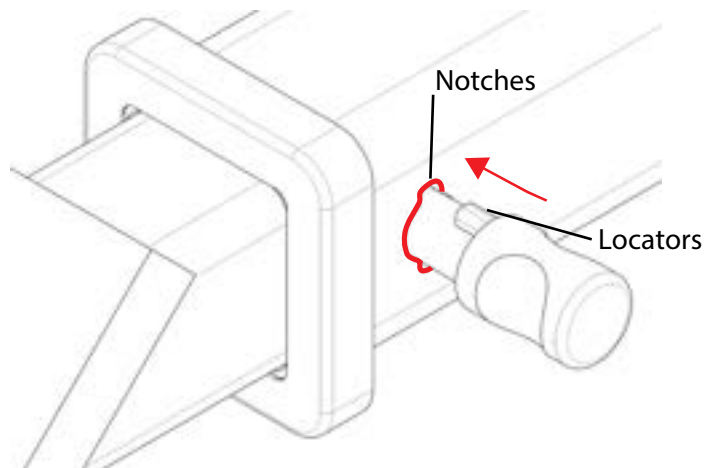

Fig 3. Silent Anti-Rattle Hitch Pin orientation

STEP 2

Insert HITCH PIN through hole in HITCHBOX and hole in TBM SHANK; ensure the LOCATORS are inserted into the NOTCHES in the HITCHBOX (Fig. 3).

STEP 3

Screw HITCH PIN NUT onto HITCH PIN; tighten HITCH PIN NUT until finger tight, ensuring TBM is restrained from movement.

STEP 4

Tighten HITCH PIN NUT by turning nut a further 1/8th of a turn in the clockwise direction using a 24mm spanner (Fig. 4).

STEP 5

Install HITCH PIN R CLIP through the hole on the HITCH PIN (Fig. 1).

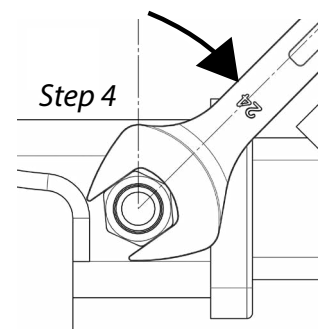

Fig 4. Tightening of Silent Anti-Rattle Hitch Pin Nut