



# TOWBAR INSTALLATION INSTRUCTIONS

PART NUMBER QTVW227L

VOLKSWAGEN CRAFTER SY VAN CL4

## PRODUCT DETAILS:

<b>Part Number:</b>	QTVW227L	<b>Maximum Towing Braked:</b>	2500	kg
<b>ECU Number:</b>	N/A	<b>Maximum Towing Unbraked:</b>	750	kg
<b>Tail Harness Length Required:</b>	1200 mm	<b>Maximum Static Ball Load:</b>	250	kg
<b>TBM/Lug Part Number:</b>	21378			

## FITTING DETAILS:

<b>Towbar Installation Time:</b>	55 Mins.	<b>RPA Disable/Other:</b>	YES
<b>Total Installation Time:</b>	70 Mins.		
<b>Bumper Cut Required:</b>	Yes		

### TRAILBOSS RECOMMENDS THAT INSTRUCTIONS ARE READ AND UNDERSTOOD COMPLETELY PRIOR TO FITMENT.

#### BEFORE YOU START:

Check all hardware items have been included refer to assembly diagram.  
Please ensure this towbar is only fitted to vehicle models as per Trailboss application guide.

#### Bumper Cuts

Vehicle and bumper variations can and do occur during vehicle manufacture after initial towbar design. Fitment of towbar to vehicle and accuracy of bumper cut must be assessed prior to any bumper modifications made. Incorrect bumper cuts are not covered under Trailboss warranty.

**NOTE: Bumper cuts need to be approached with care, refer to notes below.**

- Bumper centreline – where the centreline of the bumper needs to be determined, the installer must assess centre point by measurement of bumper width or determining two symmetrical reference points to give centreline.
- Bumper edge – To assist with accurate bumper cut measurement, reference to the start of the bumper edge is now being commonly used.
  - Measure from bottom edge along bumper and around corner to the 70 mm point (Figure 1).
  - Do not measure from visible bumper front of corner, upwards (Figure 2).

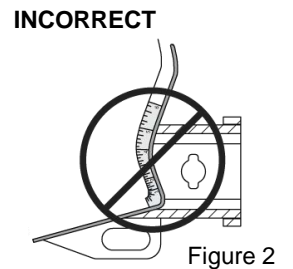
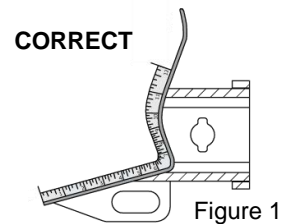

#### Drilling

- For any required drilling during installation, ensure that the area is clear of fuel, electrical & other components that may be damaged.
- All holes drilled into metal body panels shall have all burrs & swarf removed then coated with a suitable rust preventative paint.

#### Bolts/Fasteners

- Ensure that all hardware is fastened to correct torque as specified in this fitting instruction.
- All fasteners supplied with this product are used to achieve a specified clamp loading. If replacement is required ensure that fasteners of the same grade and class are used.

**NOTE: Achieving correct torque is critical to proper installation and responsibility of the installer. Towbar failures attributed to tension issues from over tightening or under tightening are not covered by Trailboss warranty.**

#### Product Labels

- a. Towbar load rating sticker provided with this product shall be conspicuously located on inside rear end of the driver's door.

### WARNING:

**Do not, drill, cut, weld or otherwise modify the towbar.  
FOR TOWING PURPOSES ONLY - This towbar is designed and tested by Trailboss to adhere to ADR 62/02 which provides only for the expected load demands of towing.**

### **i** TOWBAR ASSEMBLY DIAGRAM

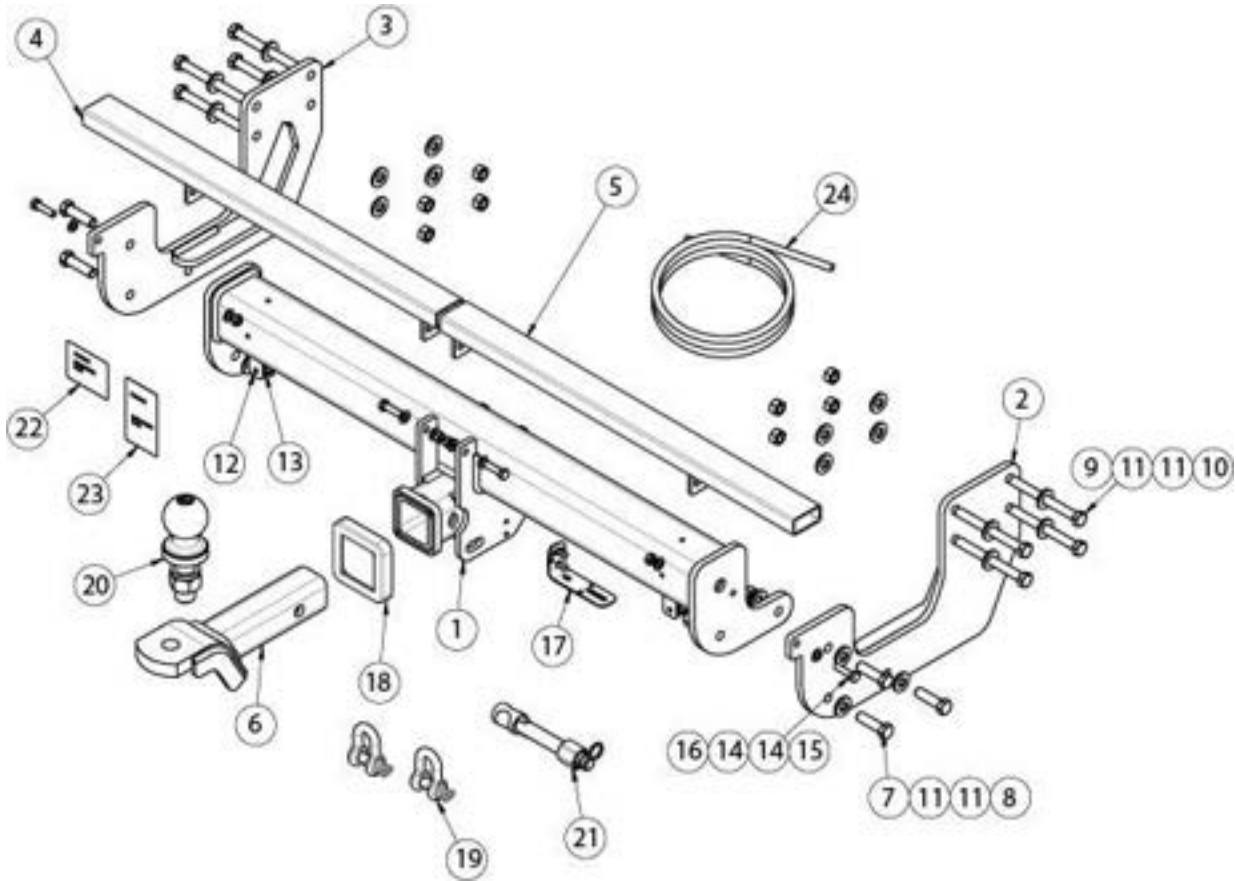

ITEM	DESCRIPTION	QTY
1	VW CRAFTER VAN WELDED ASSEMBLY	1
2	SIDE ARM - RHS ASSY	1
3	SIDE ARM - LHS ASSY	1
4	STEP SUPPORT – LHS	1
5	STEP SUPPORT – RHS	1
6	TRIALER BALL MOUNT	1
7	BOLT HEX HD M12x45x1.75P	6
8	NUT HEX HD M12x1.75P	4
9	BOLT HEX HD M12x120x1.25P	8
10	NUT HEX HD M12x1.25P	8
11	WASHER PLAIN 1/2"	26
12	BUMPER TAB	2

ITEM	DESCRIPTION	QTY
13	TEK SCREW 14-20 HEX HD 22mm	2
14	WASHER PLAIN M8x18x1.2	8
15	SET SCREW HEX HD M8x30x1.25P	4
16	NUT HEX HD M8x1.25P	4
17	UNIVERSAL PLUG BRACKET KIT	1
18	HITCH BOX COLLAR COVER	1
19	"D" SHACKLE 10mm	2
20	TOWBALL 50mm	1
21	SMART PIN SILVER	1
22	COMPLIANCE LABEL	1
23	LOAD RATING LABEL	1
24	WIRE LOOM	1

1. On the RHS.  
Remove 4x screws and 6x plastic nuts.  
Remove the plastic cover.

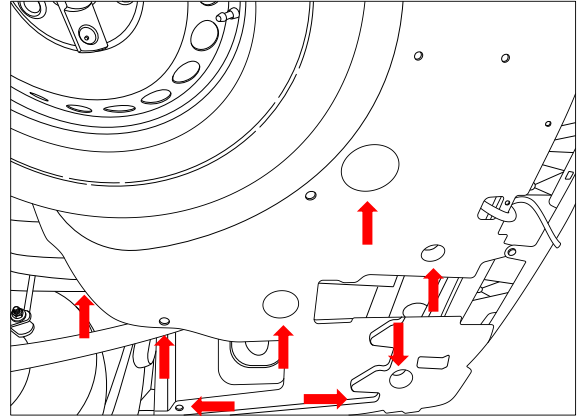

2. On the LHS.  
Remove 5x plastic nuts.

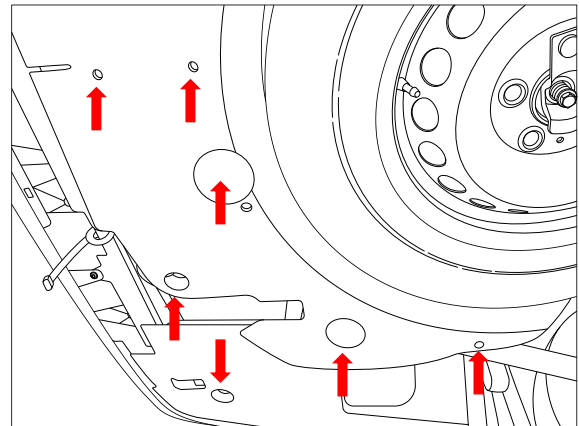

3. Remove 4x screws on top and 2x screws on the bottom of the bumper.  
Unclip the sensor wire and remove plastic bumper.

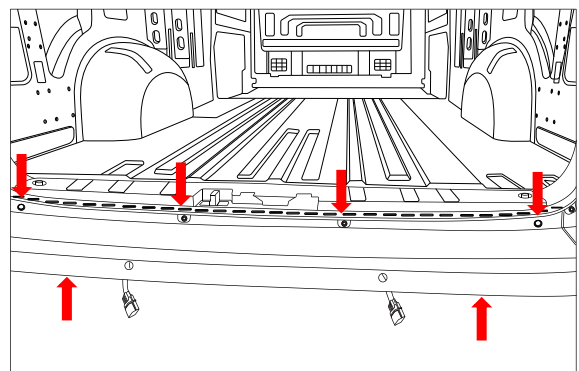

- 
4. Remove 6x bolts.  
Discard the bolts and the impact beam.

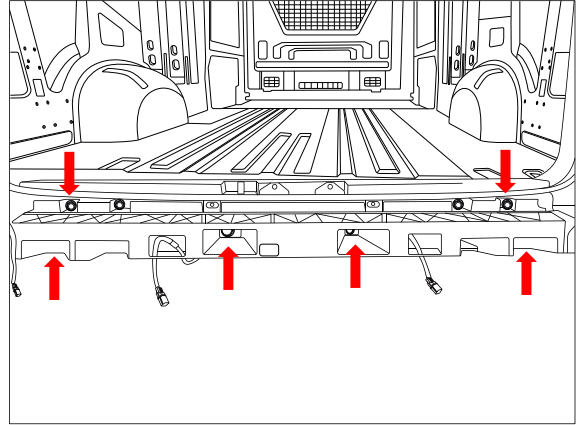

- 
5. Place the side arm to the chassis.  
Loosely secure with 4x M12 bolts, 8x washers  
and 4x nuts.

Repeat for other side.

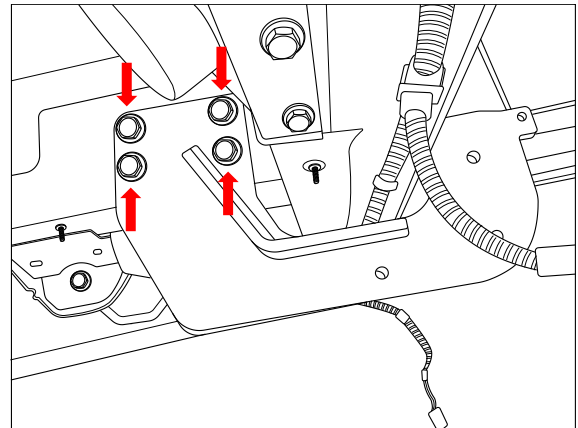

- 
6. Place the cross tube between the side arms.  
Loosely secure with 3x M12 bolts, 5x washers  
and 2 nuts.

Repeat for other side.

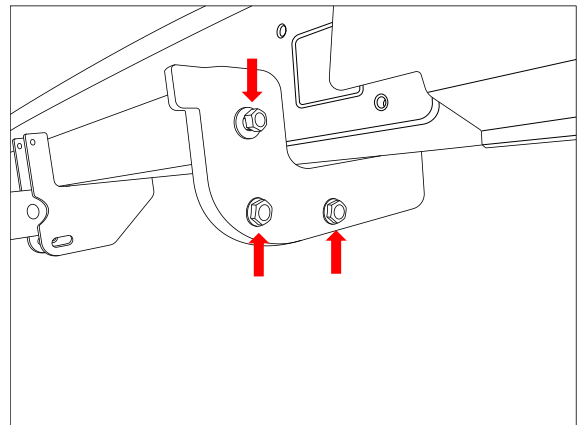

- 
7. Fit the bumper support tube and secure with 2x bolts, 4x washers and 2x nuts.

Fit the bumper tab under the cross tube and secure with a Tek screw.

Repeat for the other side.

**Torque fasteners as follows:**

**M14 x 2.0 = 175 Nm**

**M12 x 1.75 = 109 Nm**

**M8 x 1.25 = 22 Nm**

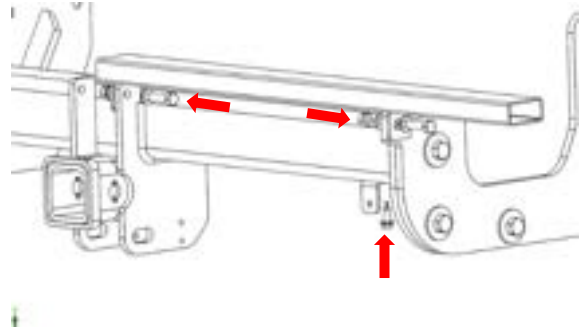

- 
8. Fit the plug bracket to the dropper and secure with 2x M4 screws, 4x washers and 2x nuts.

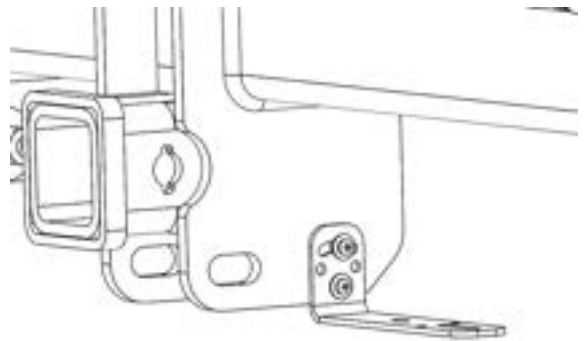

- 
9. Locate the trailer prep 14-way connector located on the LHS chassis.  
10. Disconnect the blanking plug.  
11. Patch in the trailer patch (102647-WL) into the trailer prep 14-way connector.  
12. Patch the tail (1200mm) into the mating blue connector.  
13. Waterproof the connectors using electrical grease (not supplied).  
14. Route the tail along the cross tube and mount the trailer plug to the plug bracket.  
15. Refit remove parts from step 1-3 in reverse.  
16. Test the trailer patch light functions.  
17. Place fitting instructions in glovebox after fitment.

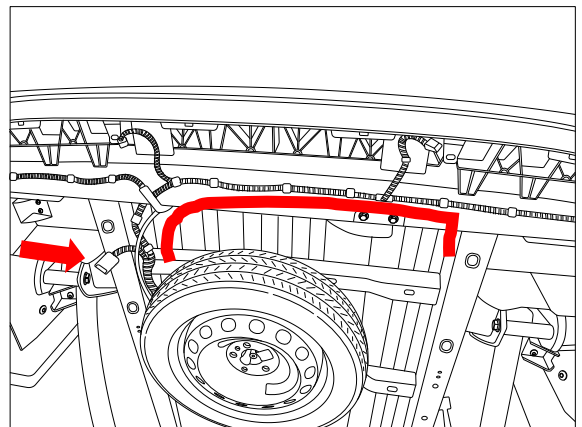



## CUSTOMER INFORMATION

PLACE THESE INSTRUCTIONS IN THE  
VEHICLE'S GLOVEBOX AFTER INSTALLATION

**THANK YOU FOR PURCHASING TRAILBOSS. WITH CORRECT MAINTENANCE AND CARE  
THIS PRODUCT WILL PROVIDE A LIFETIME OF TROUBLE-FREE OPERATION.**

### **TOWBAR MAINTENANCE AND CARE:**

1. Trailboss recommend that the towbar LUG or TBM (Trailer Ball Mount) Pull Pin and R-clip are removed and stored when not in use. Removal of LUG or TBM (Trailer Ball Mount) is advisable when not in use to assist with any of the following.
  - Ensure rear number plate is not obscured.
  - Allow maximum available departure angle and prevent any potential interference.
  - Prevent possible interference with vehicles reverse sensors or camera detecting a tow ball mount as an obstruction during reversing.
  - Removes towball mount as an obstruction for when moving around the rear of the vehicle.
2. Trailboss recommends routine inspection of your towbar to ensure trouble free towing.
  - Bolt security and tension should be regularly inspected and checked for correct tension. Replace any worn or defective parts with suitable grade & class fasteners. Inspection should be requested to coincide with vehicle major services.
3. It is the owner's responsibility to ensure towing and down ball weight capacities of the towing vehicle are not exceeded.
  - Towing and down ball weights allowable may differ according to model variations. Please refer to owner's manual or vehicle dealer to confirm exact rating for your vehicle model variant.
  - It is not uncommon for the vehicle tow rating to differ from the towbar rating. When this occurs, the lesser rating must be adhered to.
  - For vehicles fitted with enhanced vehicle functions that may be altered/changed when towing i.e Trailer sway mitigation, blind spot detection, adaptive cruise control etc. Please consult owner's manual to understand changes enabled when towing and after towing.

### **WARRANTY INFORMATION:**

Trailboss Towbars are covered by a Lifetime Warranty.

Our goods come with guarantees that cannot be excluded under the Australian Consumer Law. You are entitled to a replacement or refund for a major failure and for compensation for any other reasonably foreseeable loss or damage. You are also entitled to have the goods repaired or replaced if the goods fail to be of acceptable quality and the failure does not amount to a major failure.

For further details please contact customer service on 1800 812 017.

## PRO SERIES SILENT ANTI-RATTLE HITCH PIN

Your Trailboss towbar is equipped with a Pro Series Silent Anti-Rattle Hitch Pin technology to help reduce towbar tongue rattle in most driving conditions. Please ensure below instructions are understood and routine maintenance is carried out to ensure best towing experience.

Regularly inspect for wear and check the tightness of the Silent Anti-Rattle Hitch Pin. Follow instructions below to re-tighten the nut as necessary when movement and noise in the tow ball mount is noted.

- Before towing, ensure R-Clip is properly installed and hitch pin nut is installed and tensioned. Replacement parts are available from your Pro Series Distributor.

## TOWBALL MOUNT REMOVAL/INSTALLATION

### STEP 1

Insert Trailer Ball Mount (TBM) (a) into towbar hitchbox (b), aligning hole in TBM shank (c) with hole in hitchbox (d) (Fig. 1)

### STEP 2

Insert Silent Anti-Rattle Hitch Pin (e) through hole in hitchbox and hole in TBM shank (g); ensure the locators are inserted into the notches in the hitchbox (Fig. 2)

### STEP 3

Screw Silent Anti-Rattle Hitch Pin Nut (f) onto Smart Pin (g); tighten Smart Pin Nut until finger tight, ensuring TBM is restrained from up and down movement.

### STEP 4

Tighten Silent Anti-Rattle Hitch Pin Nut by turning nut a further 1/8th of a turn in the clockwise direction using a 24mm spanner (Fig. 4).

### STEP 5

Install Silent Anti-Rattle Hitch Pin R-Clip through the hole that provides best clearance or easiest access. (Fig. 5)

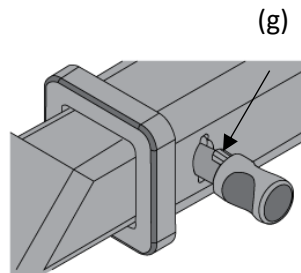
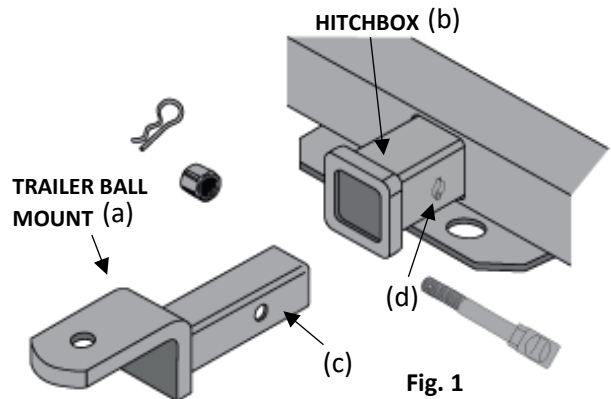

Fig. 2

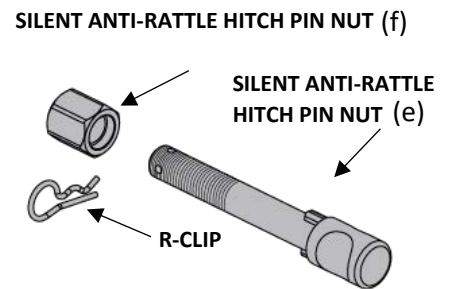

Fig. 3

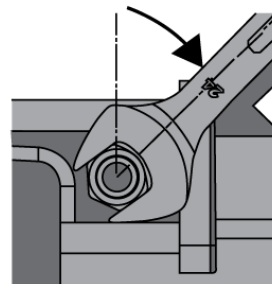

Fig. 4

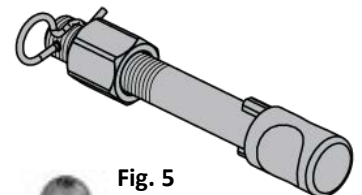

Fig. 5

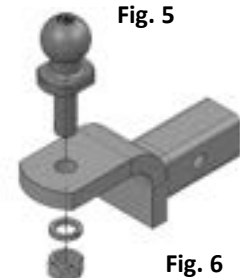

Fig. 6