

TRAILBOSS

Towbar Fitting Instructions
To Suit TOYOTA HILUX 04/05 - ON
Part Number TT145L
Rating 1250Kg

WARNING:

1. Do not, drill, cut, weld or other wise modify the towbar.
2. If you are using electric welding on a motor vehicle, **always** check that the vehicle is not equipped with electronic engine or instrument management equipment. Failure to do so could **destroy** any onboard computers. If in doubt, check with the vehicle's manufacturer.



CAUTION TWO PERSON LIFT REQUIRED TO FIT THIS PRODUCT

Max. Towing Weight: 1250kg

1. Ensure all hardware items have been included.
2. Offer towbar to chassis rails aligning holes in side plates with captive nuts in chassis rails.
3. Fit 4 M12 x 1.25 bolts flat & spring washers two each into captive nuts loosely.
4. Feed bolts on wire up chassis rails two per side then feed through existing holes.
5. Fit 4 M12 nuts flat & spring washers supplied.
6. Fasten all bolts & nuts to torque listing below.
7. Trim excess wire off bolts on wire that have been fed down the chassis rails.
8. **Note: the lug supplied (lug# 7581) should be fitted in the down position for 4x4, and the up position for 4x2 models.**

NOTE: TRAILBOSS recommends that you check your towball to ensure it complies with Australian Design Rules.

RECOMMENDED ASSEMBLY TORQUE LISTING

Diameter Grade 8.8 Bolt

	Nm
M6	9.5
M8	21.7
M10	43.4
M12	77.3
M16	189.8

FOR TOWING PURPOSES ONLY

For towing capacity details please refer to vehicle owner's manual or to the manufacturer. Overloading can void your warranties.

PLEASE NOTE: You must remove the lug unless you are actually towing if it obscures your number plate. Failure to do so may result in a fine.



Towbar Fitting Instructions
To Suit TOYOTA HILUX 04/05 - ON
Part Number TT145L
Rating 1250Kg

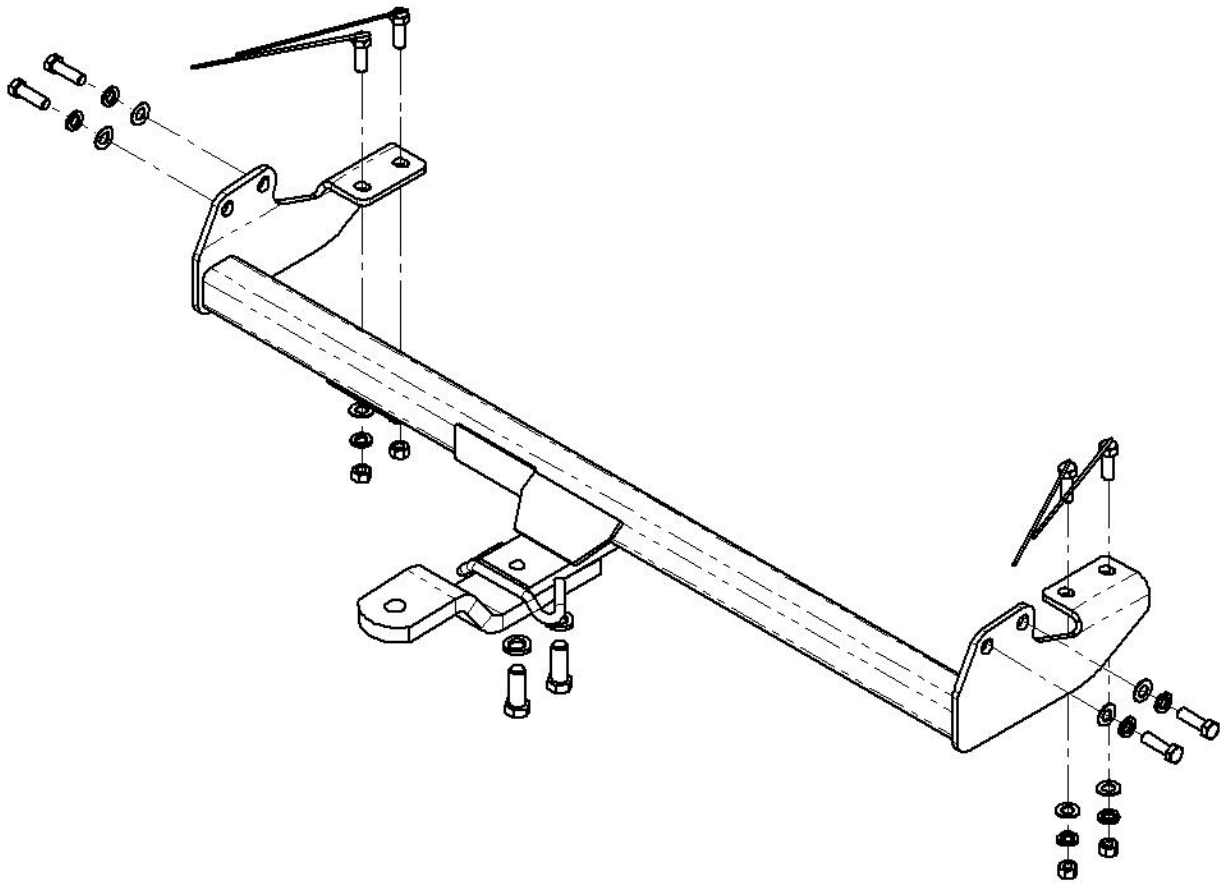

Lug shown in "up position" for 4x2 models.



Wiring Loom Fitting Instructions
To Suit Toyota Hilux
Hilux Cab Chassis & Tub Body – 4x4 & 4x2

Part Number 100002-WL

Wiring Loom Installation Instructions

**Toyota Hilux
Hilux Cab Chassis & Tub Body – 4x4 & 4x2**

Part No: 100002-WL

**Tail Harness Length Required: 1800mm
RPA Override Switch Part No: 04848 (If Fitted)**

Wiring Loom Installation Time: Approx 20 Mins



Wiring Loom Fitting Instructions
To Suit Toyota Hilux
Hilux Cab Chassis & Tub Body – 4x4 & 4x2

Part Number 100002-WL

1. Disconnect and remove the tail light on both sides of the vehicle by removing the two fasteners on each tail light assembly.
2. From underneath the vehicle, route the Trailer Patch Harness (P/No:100002-WL) connectors up the RHS tail light cavity.
3. Patch the Trailer Patch Harness RHS connectors in between the tail light connectors.
4. Refit the RHS tail light assembly.
5. Underneath the vehicle, route the Trailer Patch Harness over the support bar and along the vehicle harness towards the LHS tail light cavity.
6. Retrieve the Trailer Patch Harness connectors.
7. On the Tail Harness (length 1800mm) and mating connector, apply electrical grease or silicon on to the back of the connectors to make them water proof.
8. Connect the Trailer Patch Harness tail connector and the Tail Harness connector together.
9. Reconnect the LHS tail lights and refit the tail light assembly.
10. Mount the Tail Harness socket to the towbar mounting plate using M4 fasteners.
11. Test the Trailer socket using a light board or multi-meter.
12. Secure the all harnesses using cables ties (not supplied). Refit all removed parts and secure all fasteners. Place instructions in glove box after fitment.