



Towbar Fitting Instructions  
To Suit **TOYOTA COROLLA SEDAN 2013 ON**  
Part Number **TT159L**  
Rating **1300/130 kg**

PLACE THESE INSTRUCTIONS IN THE VEHICLE'S GLOVEBOX AFTER INSTALLATION IS COMPLETED

**WARNING:**

1. Do not, drill, cut, weld or otherwise modify the tow bar.
2. If you are using electric welding on a motor vehicle, **always** check that the vehicle is not equipped with electronic engine or instrument management equipment. Failure to do so could **destroy** any onboard computers. If in doubt, check with the vehicle's manufacturer.
3. The high tensile fasteners supplied with this product were used to achieve the specified rating. If replacement is required ensure that fasteners of the same rating & quality are used. Contact an authorised **Trailboss** dealer if further information is required.

**General:**

1. Ensure all hardware items have been included refer to assembly diagram.
2. It is recommended that the instructions are read through and completely understood before making any attempt to fit this product.
3. Be wary of any changes to vehicle designs or other accessories that may conflict with the installation of this product.
4. Before drilling ensure that the area is clear of fuel, electrical & other components.
5. All holes drilled into the body panels shall have all burrs & swarf removed then coated with a suitable rust preventative paint.
6. For vehicles that require the bumper to be cut. Ensure cut out area is in correct position on the vehicle prior to cutting the bumper.
7. The high tensile fasteners supplied with this product were used to achieve the specified rating. If replacement is required ensure that fasteners of the same rating & quality are used. Contact an authorized **Trailboss** dealer if further information is required.
8. Ensure that all hardware is fastened to torque list below check fasteners on regular basis.
9. Tow bar load rating sticker provided with this product shall be conspicuously located on inside rear end of the driver's door. **(See diagram below).**
10. Trailboss recommends that you check your tow ball to ensure that it complies with the Australian standards **AS 4177.2.**
11. **PLEASE NOTE:** It is advised to remove your lug or tbm when not actually towing so as to produce a clear view of the vehicles registration plate if obscured, and to also provide maximum available departure angle
12. Pull Pin must be fit in down position.

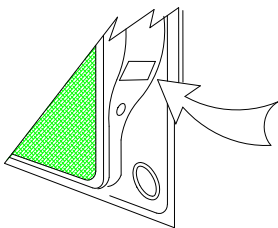

Place load rating sticker  
inside driver's door here

**FOR TRAILER TOWING PURPOSES ONLY**  
For towing capacity details please refer to vehicle owner's manual or to the manufacturer. Overloading can void your warranties.

**RECOMMENDED ASSEMBLY TORQUE LISTING**

Diameter	Grade 8.8 Bolt
M6	9.5 Nm
M8	21.7 Nm
M10	43.4 Nm
M12	77.3Nm
M14	146 Nm
M16	189.8 Nm

**Tow bar Maintenance and Care.**

Trailboss recommends that bolt torque's, as listed below, are routinely and regularly inspected and checked for correct tension. Replace any worn or defective parts.

We recommended to remove Tow Ball Mounts (TBM's, tongues or lugs) when not being used for any considerable length of time.

So as to avoid injury, when not towing it is suggested that the tongue, Pull Pin and R-clip are removed then stored in a safe, clean and dry place, away from excessive moisture.

# TRAILBOSS

Towbar Fitting Instructions  
 To Suit **TOYOTA COROLLA SEDAN 2013 ON**  
 Part Number **TT159L**  
 Rating **1300/130 kg**

PLACE THESE INSTRUCTIONS IN THE VEHICLE'S GLOVEBOX AFTER INSTALLATION IS COMPLETED

Hitch Pull Pins and spring "R" clips are regularly checked for proper installation. Replace any worn or defective parts.

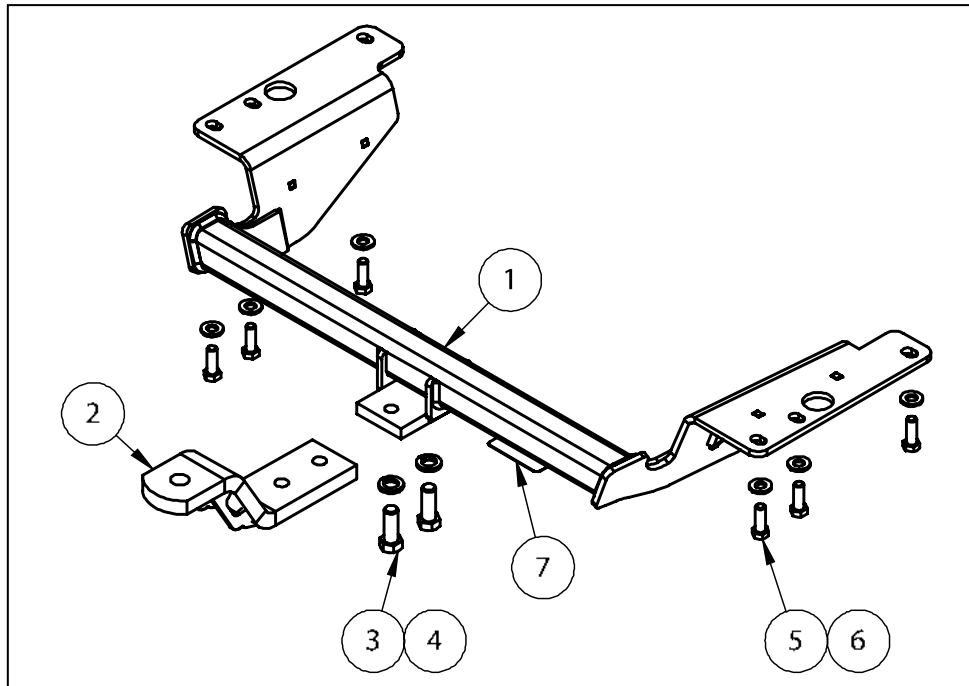

QTY	DESCRIPTION	ITEM NO
1	TOWBAR ASSEMBLY	1
1	LUG ASSEMBLY	2
2	M16x45x2.0P BOLT	3
2	M16 SPRING WASHER	4
6	M12x35x1.25P HEX BOLT	5
6	1/2" FLAT WASHER	6
1	ACRYLIC CP LABEL	7

ADDITIONAL ITEMS

WIRING LOOM      FITTING INSTRUCTION      LR LABEL

PLUG BRACKET      NUT NYLOC

# TRAILBOSS

Towbar Fitting Instructions  
To Suit **TOYOTA COROLLA SEDAN 2013 ON**  
Part Number **TT159L**  
Rating **1300/130 kg**

PLACE THESE INSTRUCTIONS IN THE VEHICLE'S GLOVEBOX AFTER INSTALLATION IS COMPLETED

## INSTRUCTION:

1. Remove all Screws and Scrivets from Bumper from inside the LH & RH Wheel Arc.
2. Remove remainder of Scrivets from underneath Bumper.
3. Open Boot and remove Screws from inside edge of Bumper on both LH & RH side.  
Firmly pull on Bumper to release from Clips.
4. Offer Towbar to vehicle and loosely bolt into place.
5. Tighten all Bolts to torque specifications provided on Page 1.
6. Create Bumper cut in the middle of the bottom edge of the Bumper, 65mm high from the bottom edge and 100mm wide.

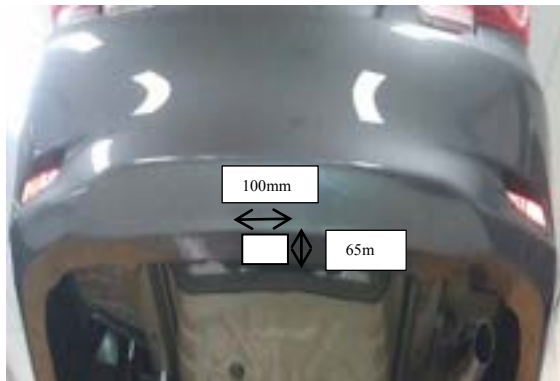



Wiring Loom Fitting Instructions  
To Suit Toyota Corolla Sedan  
Part Number 100059-WL

## Wiring Loom Installation Instructions

Toyota Corolla Sedan  
Part No: 100059-WL  
ECU: 04826

Tail Harness Length Required: 1200mm  
RPA Override Switch Part No: 04848 (If Fitted)

Wiring Loom Installation Time: Approx 30 Mins



Wiring Loom Fitting Instructions  
To Suit Toyota Corolla Sedan  
Part Number 100059-WL

1. In the In the luggage compartment, remove the floor cover carpet.
2. Fold the rear seats forward.
3. Remove the rear trim, by first removing the two clips.
4. Dislodge the LHS side trim, by first removing the two clips.
5. In the vehicle cabin, remove the rear seat cushion.
6. Remove the LHS rear scuff plate.
7. Remove the LHS kick plate.
8. Remove the LHS front scuff plate.
9. In the luggage compartment, disconnect the LHS tail light connectors.
10. Patch in the trailer patch (P/No: 100059-WL) mating connectors.
11. Locate the vehicle wiring loom on the LHS of the luggage compartment.
12. Cut open the corrugated tube and locate the vehicle 'RED' reverse wire.
13. Following the table below, connect the ezy tap to the vehicle harness wire and then connect the trailer harness terminal to the corresponding wire.

Function	Trailer Patch	Vehicle Connector
REVERSE	BLACK / WHITE	RED

14. Route the trailer harness from the LHS across the rear of the luggage compartment towards the RHS of the vehicle.
15. Connect the trailer harness ground ring terminal to the vehicle ground point on the rear of the luggage compartment.
16. Locate and disconnect the RHS tail light connectors.
17. Route the trailer harness up towards the RHS tail light access panel.
18. Patch in the trailer patch mating connectors.
19. Route the 'ORANGE' power wire along the LHS of the vehicle towards the front of the vehicle.
20. Continue to route the 'ORANGE' power wire along the LHS of the vehicle, towards the dash.
21. Under the LHS dash, locate and remove the fuse panel cover.
22. Place in vehicle glove compartment for safe keeping.
23. Insert the supplied 20-amp fuse into the upper slot of the add-a-fuse harness.



Wiring Loom Fitting Instructions  
To Suit Toyota Corolla Sedan  
Part Number 100059-WL

24. Plug the add-a-fuse harness into an available fuse slot on the fuse panel.
25. Connect the 'ORANGE' power wire 1-way connector into the add-a-fuse harness mating connector.
26. Connect the trailer harness 12-way connector to the ECU (04826).
27. Apply double sided tape to the ECU and adhere it to the outward face of the inner sheet metal on the LHS of the luggage compartment.
28. From outside the vehicle, mount the trailer socket to the towbar mounting bracket using M4 fasteners (not supplied).
29. Route the tail harness across the towbar towards the LHS of the vehicle and up through the previously drilled out hole.
30. Ensure the tail harness grommet is seated correctly and secure in place using a cable tie (not supplied).
31. Inside the luggage compartment, connect the tail harness (tail length 1200mm) 8-way connector to the trailer harness mating 8-way connector.
32. Test the Trailer socket using a light board or multi-meter.
33. Secure the all harnesses using cables ties (not supplied).
34. Re-fit all removed parts and secure all fasteners.
35. Place instructions in glove box after fitment.