

TRAILBOSS

Towbar Fitting Instructions
To Suit **TOYOTA CAMRY ASV50R & AVV50R & AURION GSV50R**
Part Number **TT163L**
Rating **1200/120 kg**

PLACE THESE INSTRUCTIONS IN THE VEHICLE'S GLOVEBOX AFTER INSTALLATION IS COMPLETED

WARNING:

1. Do not, drill, cut, weld or otherwise modify the tow bar.
2. If you are using electric welding on a motor vehicle, **always** check that the vehicle is not equipped with electronic engine or instrument management equipment. Failure to do so could **destroy** any onboard computers. If in doubt, check with the vehicle's manufacturer.
3. The high tensile fasteners supplied with this product were used to achieve the specified rating. If replacement is required ensure that fasteners of the same rating & quality are used. Contact an authorised **Trailboss** dealer if further information is required.
4. If TBM is used in inverted position tow ball may make contact with rear tailgate when lowered, which could cause damage.

General:

1. Ensure all hardware items have been included refer to assembly diagram.
2. It is recommended that the instructions are read through and completely understood before making any attempt to fit this product.
3. Be wary of any changes to vehicle designs or other accessories that may conflict with the installation of this product.
4. Before drilling ensure that the area is clear of fuel, electrical & other components.
5. All holes drilled into the body panels shall have all burrs & swarf removed then coated with a suitable rust preventative paint.
6. For vehicles that require the bumper to be cut. Ensure cut out area is in correct position on the vehicle prior to cutting the bumper.
7. The high tensile fasteners supplied with this product were used to achieve the specified rating. If replacement is required ensure that fasteners of the same rating & quality are used. Contact an authorized **Trailboss** dealer if further information is required.
8. Ensure that all hardware is fastened to torque list below check fasteners on regular basis.
9. Tow bar load rating sticker provided with this product shall be conspicuously located on inside rear end of the driver's door. **(See diagram below).**
10. Trailboss recommends that you check your tow ball to ensure that it complies with the Australian standards **AS 4177.2**.
11. **PLEASE NOTE:** It is advised to remove your LUG or TBM when not actually towing so as to produce a clear view of the vehicles registration plate if obscured, and to also provide maximum available departure angle

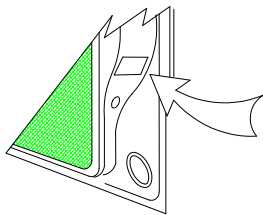

Place load rating sticker
inside driver's door here

FOR TRAILER TOWING PURPOSES ONLY
For towing capacity details please refer to vehicle owner's manual or to the manufacturer. Overloading can void your warranties.

RECOMMENDED ASSEMBLY TORQUE LISTING

Diameter	Grade 8.8 Bolt
M6	9.5 Nm
M8	21.7 Nm
M10	43.4 Nm
M12	77.3Nm
M14	146 Nm
M16	189.8 Nm

Tow bar Maintenance and Care.

Trailboss recommends that bolt torque's, as listed below, are routinely and regularly inspected and checked for correct tension. Replace any worn or defective parts.

We recommended to remove Tow Ball Mounts (TBM's, tongues or lugs) when not being used for any considerable length of time.

So as to avoid injury, when not towing it is suggested that the tongue, Pull Pin and R-clip are removed then stored in a safe, clean and dry place, away from excessive moisture.

Hitch Pull Pins and spring "R" clips are regularly checked for proper installation. Replace any worn or defective parts.

Cequent Customer Service
Ph: 1800 812 017 Fax: 03 9898 3299
Email: info@cequent.com.au
Post: PO Box 4050, Dandenong South VIC 3175

TRAILBOSS

Towbar Fitting Instructions
 To Suit **TOYOTA CAMRY ASV50R & AVV50R & AURION GSV50R**
 Part Number **TT163L**
 Rating **1200/120 kg**

PLACE THESE INSTRUCTIONS IN THE VEHICLE'S GLOVEBOX AFTER INSTALLATION IS COMPLETED

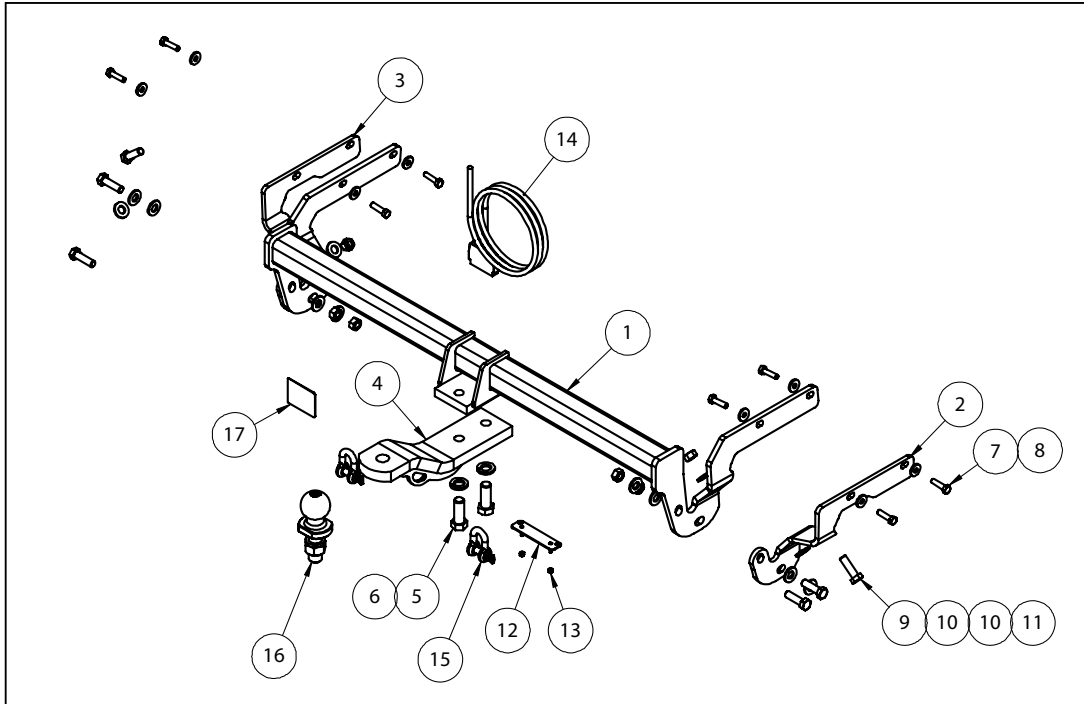

QTY.	DESCRIPTION	ITEM NO.
1	WELDED ASSY	1
1	SIDEARM BRACKET-RHS	2
1	SIDEARM BRACKET-LHS	3
1	LUG ASSEMBLY	4
2	BOLT M16x45 2.0P	5
2	SPRING WASHER M16x5x3.5	6
8	BOLT HEX M8-1.25x30mm GR10.9	7
8	FLAT WASHER M8x22x3.3mm	8
6	BOLT M12-1.25x40 GR8.8	9
12	WASHER FLAT 1/2"x1 1/8"x1/8"	10
6	HEX NUT M12x1.25 PC8	11
1	PLUG BRACKET	12
2	NUT NYLOC M4-0.7 Z/P	13
1	WIRING LOOM	14
2	10mm "D" SHACKLE	15
1	50mm TOWBALL	16
2	ACRYLIC COMPLIANCE PLATE	17

Cequent Customer Service
 Ph: 1800 812 017 Fax: 03 9898 3299
 Email: info@cequent.com.au
 Post: PO Box 4050, Dandenong South VIC 3175

TRAILBOSS

Towbar Fitting Instructions

To Suit **TOYOTA CAMRY ASV50R & AVV50R & AURION GSV50R**

Part Number **TT163L**

Rating **1200/120 kg**

PLACE THESE INSTRUCTIONS IN THE VEHICLE'S GLOVEBOX AFTER INSTALLATION IS COMPLETED

1. If mudflaps are fitted, remove 3 x fasteners within rear wheel arch securing the mudflaps to vehicle; remove mudflaps.

Repeat for opposite side of vehicle.

2. Remove 2 x Screws from rear wheel arch securing rear bumper.



3. Remove 2 x push rivets and 4 x Screws located on the underside of rear bumper.

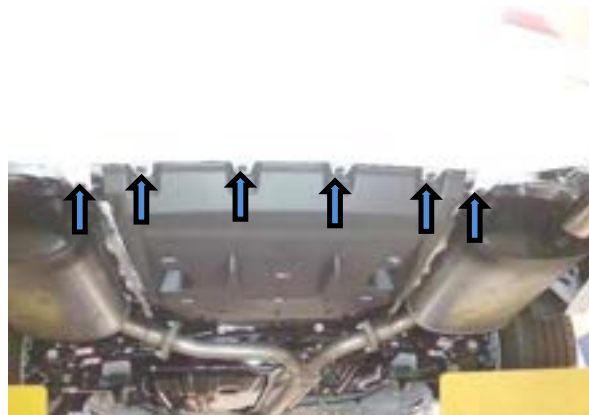

4. If fitted, remove the undercover by removing 5 x flanged Nuts.



Cequent Customer Service

Ph: 1800 812 017 Fax: 03 9898 3299

Email: info@cequent.com.au

Post: PO Box 4050, Dandenong South VIC 3175

TRAILBOSS

Towbar Fitting Instructions
To Suit **TOYOTA CAMRY ASV50R & AVV50R & AURION GSV50R**
Part Number **TT163L**
Rating **1200/120 kg**

PLACE THESE INSTRUCTIONS IN THE VEHICLE'S GLOVEBOX AFTER INSTALLATION IS COMPLETED

5. Remove 2 x covers on the rear bumper to access screws securing the bumper to the body; remove 2 x Screws from beneath the covers.
6. Remove and disconnect both tail lights.
7. Carefully remove bumper.



8. Remove and discard 6 x Nuts securing impact beam to rear panel; remove and discard impact beam.



9. Lower the exhaust(s) off the rubber mounts (3 places each). Remove 3 x Bolts securing the exhaust bracket(s) and remove the rear exhaust bracket(s).
10. Remove heat shield(s) (3 Bolts) from the vehicle located above muffler(s).



Cequent Customer Service
Ph: 1800 812 017 Fax: 03 9898 3299
Email: info@cequent.com.au
Post: PO Box 4050, Dandenong South VIC 3175

TRAILBOSS

Towbar Fitting Instructions
To Suit TOYOTA CAMRY ASV50R & AVV50R & AURION GSV50R
Part Number TT163L
Rating 1200/120 kg

PLACE THESE INSTRUCTIONS IN THE VEHICLE'S GLOVEBOX AFTER INSTALLATION IS COMPLETED

11. Check chassis rail excess body sealer, remove any excess that may prevent sidearm fitment. Coat any bare metal exposed with rust inhibitor.



12. Offer the welded Towbar assembly to the vehicle. Loosely secure Towbar assembly mounts to the inner side of the chassis rails using 4 x M8 Bolts (2 per side), complete with 1 x flat washer per Bolt.



13. Refit any exhaust hangers. Removed in step 8.

NOTE: Brackets to be tightened only after outer chassis brackets are fitted.



Cequent Customer Service
Ph: 1800 812 017 Fax: 03 9898 3299
Email: info@cequent.com.au
Post: PO Box 4050, Dandenong South VIC 3175

TRAILBOSS

Towbar Fitting Instructions
To Suit **TOYOTA CAMRY ASV50R & AVV50R & AURION GSV50R**
Part Number **TT163L**
Rating **1200/120 kg**

PLACE THESE INSTRUCTIONS IN THE VEHICLE'S GLOVEBOX AFTER INSTALLATION IS COMPLETED

14. Loosely secure the sidearm bracket onto the outer side of the chassis rail using 2 x M8 Bolts, complete with 1 x flat washer per Bolt.

Repeat for opposite side of vehicle.

15. Loosely secure sidearm bracket to the welded towbar assembly using 3 x M12 Bolts, complete with 2 x flat washer and 1 x M12 nut per Bolt.

Repeat for opposite side of vehicle.

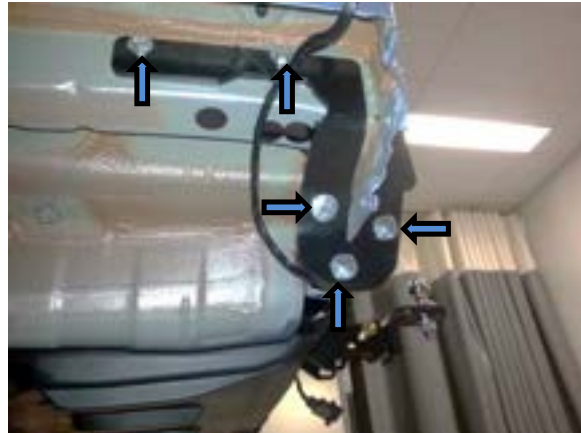

16. Tighten all fasteners to torques listed below:
M8 31N.m
M12 89N.m

17. Secure all heat shields using original fasteners and refit exhaust/s. Tighten exhaust hangers removed in step 10.



18. Temporarily refit the bumper to the vehicle and mark the location of the towbar side arms.

19. Cut the bumper at two places allowing 3-5mm each side. Dimensions of cut will be approximately 25mm tall x 35mm wide.

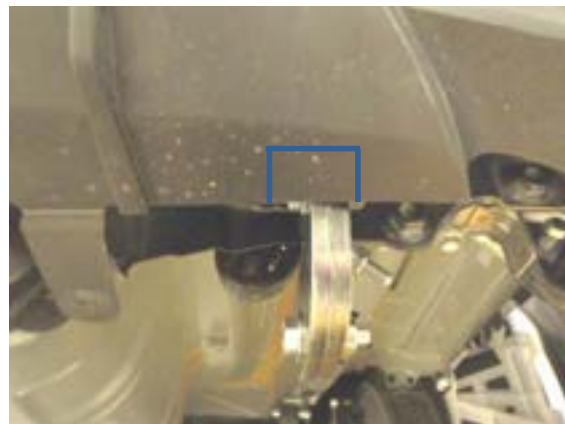

Cequent Customer Service

Ph: 1800 812 017 Fax: 03 9898 3299

Email: info@cequent.com.au

Post: PO Box 4050, Dandenong South VIC 3175



Towbar Fitting Instructions
To Suit TOYOTA CAMRY ASV50R & AVV50R & AURION GSV50R
Part Number TT163L
Rating 1200/120 kg

PLACE THESE INSTRUCTIONS IN THE VEHICLE'S GLOVEBOX AFTER INSTALLATION IS COMPLETED

ALTISE MODEL ONLY

20. Identify centre of bumper, and make cutout in centre of bumper 95mm tall x 100mm wide, starting at bottom edge of bumper (as measured on outside of bumper).

NOTE: Variation of bumper cut due to model year and variant may exist. It is highly recommended for the installer to review the cut against vehicle and proceed with caution.

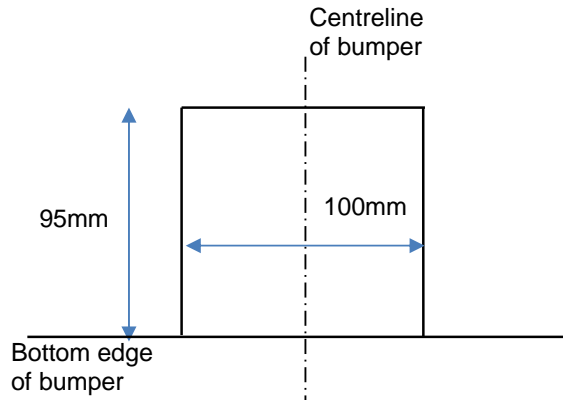

ATARA MODEL ONLY

21. Identify centre of bumper, and make cutout in centre of bumper 105mm tall x 100mm wide, starting at bottom edge of bumper (as measured on outside of bumper).

NOTE: Variation of bumper cut due to model year and variant may exist. It is highly recommended for the installer to review the cut against vehicle and proceed with caution.

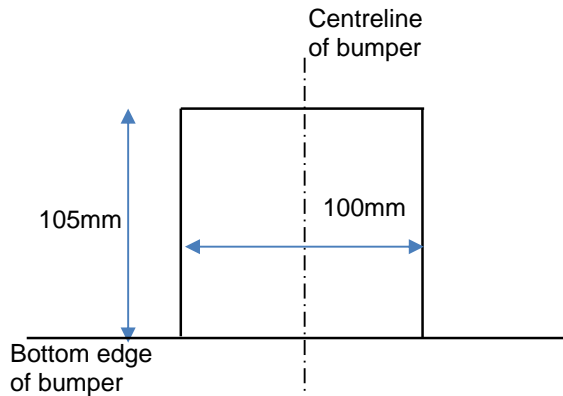

AURION MODEL ONLY – EXCLUDING SPORTIVO

22. Identify centre of bumper, and make cutout in centre of bumper 105mm tall x 100mm wide, starting at bottom edge of bumper (as measured on outside of bumper).

NOTE: Variation of bumper cut due to model year and variant may exist. It is highly recommended for the installer to review the cut against vehicle and proceed with caution.

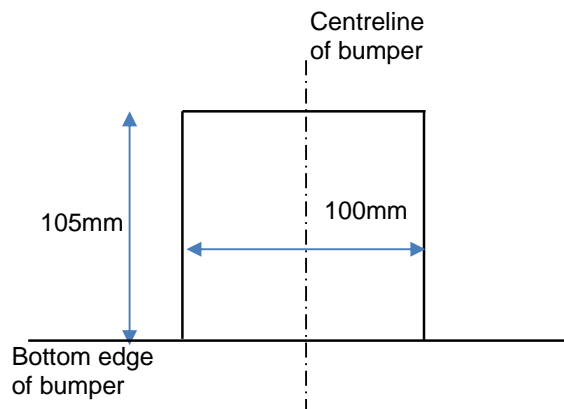

Cequent Customer Service
Ph: 1800 812 017 Fax: 03 9898 3299
Email: info@cequent.com.au
Post: PO Box 4050, Dandenong South VIC 3175

Towbar Fitting Instructions
To Suit **TOYOTA CAMRY ASV50R & AVV50R & AURION GSV50R**
Part Number **TT163L**
Rating **1200/120 kg**

PLACE THESE INSTRUCTIONS IN THE VEHICLE'S GLOVEBOX AFTER INSTALLATION IS COMPLETED

AURION MODEL ONLY – SPORTIVO ONLY

21. Identify centre of bumper, and make cutout in centre of bumper 115mm tall x 100mm wide, starting at bottom edge of bumper (as measured on outside of bumper).

NOTE: Variation of bumper cut due to model year and variant may exist. It is highly recommended for the installer to review the cut against vehicle and proceed with caution.

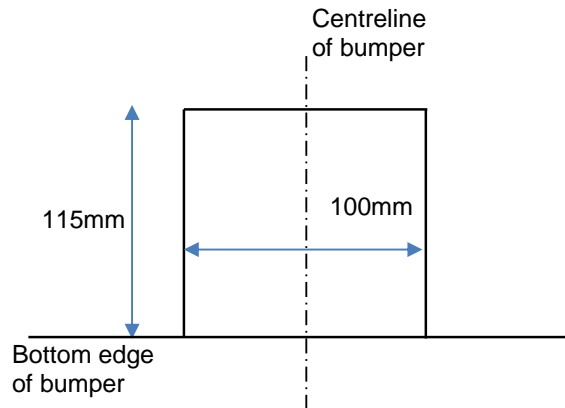

ALL MODELS

23. Mark out and drill 2 x $\varnothing 5$ mm holes 69mm apart on bumper skin to support plug bracket. Feed bracket threads through drilled holes prior to reinstalling bumper.

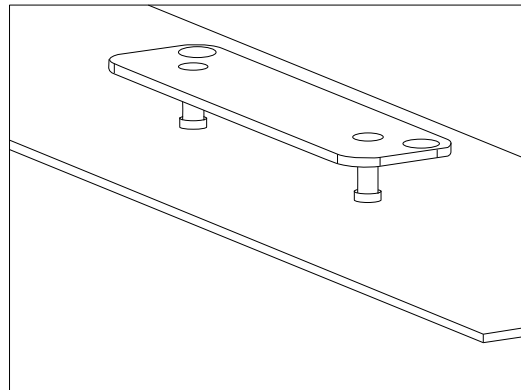

ALL MODELS

24. Reinstall bumper following steps 1-6 in reverse order.

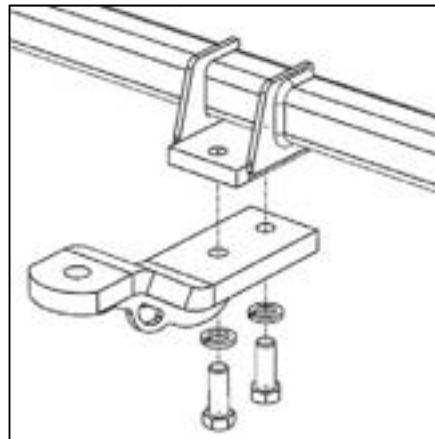

Cequent Customer Service
Ph: 1800 812 017 Fax: 03 9898 3299
Email: info@cequent.com.au
Post: PO Box 4050, Dandenong South VIC 3175



Wiring Loom Fitting Instructions
To Suit Toyota Camry
(2011 – Onwards)
Part Number 100759-WL

Wiring Loom Installation Instructions

Toyota Camry
(2011 – Onwards)
Part No: 100759-WL

ECU Required: 04826
Tail Harness Length Required: 1800mm
RPA Override Switch Part No: 04848 (If Fitted)

Wiring Loom Installation Time: Approx 30 Mins



Wiring Loom Fitting Instructions
To Suit Toyota Camry
(2011 – Onwards)
Part Number 100759-WL

1. In the luggage compartment, remove the floor carpet cover.
2. Remove the rear trim from the luggage compartment by removing the five scrivenets.
3. Remove the LHS and RHS tool storage compartment and the centre wheel cover.
4. On the LHS of the luggage compartment, remove the luggage compartment trim by removing the three scrivenets and the cargo hook.
5. On the LHS rear quarter panel, below the air vent, drill a Ø2mm pilot hole on the sheet metal floor. Drill out the sheet metal to Ø30mm.
6. File any rough or sharp edges and then spray on rust inhibitor.
7. On the LHS of the luggage compartment, disconnect the 8-way vehicle connectors and connect the trailer harness (100759-WL) connectors in between.
8. Apply double sided tape to the ECU and adhere it to the vehicle sheet metal on the LHS of the luggage compartment.
9. Connect the trailer patch 12-way Female connector to the ECU.
10. Route the trailer harness along the existing vehicle harness towards the rear of the luggage compartment.
11. Connect the trailer patch ground ring terminal to the vehicle grounding point.
12. Mount the trailer socket to the towbar mounting bracket using M4 fasteners (not supplied).
13. Route the tail harness (tail length 1800mm) towards the LHS of the vehicle and up through the previously drilled out hole.
14. Ensure the tail harness grommet is seated correctly and makes a good seal.
15. Secure the grommet in place using a cable tie (not supplied).
16. Connect the trailer harness 8-way connector to the tail harness mating connector.
17. Test the Trailer Harness function using a light board or multimeter.
18. Secure all harnesses using cable ties (not supplied).
19. Re-fit all removed parts and secure all fasteners, ensuring there are no squeaks or rattles.
20. Place the instructions in the glove box after fitment.