

# TRAILBOSS

Towbar Fitting Instructions  
To Suit **TOYOTA CHR NXG10R/NXG50R CL2**  
Part Number **TT165L**  
Rating **1100/110 kg**

PLACE THESE INSTRUCTIONS IN THE VEHICLE'S GLOVEBOX AFTER INSTALLATION IS COMPLETED

## WARNING:

1. Do not, drill, cut, weld or otherwise modify the tow bar.
2. If you are using electric welding on a motor vehicle, **always** check that the vehicle is not equipped with electronic engine or instrument management equipment. Failure to do so could **destroy** any onboard computers. If in doubt, check with the vehicle's manufacturer.
3. The high tensile fasteners supplied with this product were used to achieve the specified rating. If replacement is required ensure that fasteners of the same rating & quality are used. Contact an authorised **Trailboss** dealer if further information is required.
4. If TBM is used in inverted position tow ball may make contact with rear tailgate when lowered, which could cause damage.

## General:

1. Ensure all hardware items have been included refer to assembly diagram.
2. It is recommended that the instructions are read through and completely understood before making any attempt to fit this product.
3. Be wary of any changes to vehicle designs or other accessories that may conflict with the installation of this product.
4. Before drilling ensure that the area is clear of fuel, electrical & other components.
5. All holes drilled into the body panels shall have all burrs & swarf removed then coated with a suitable rust preventative paint.
6. For vehicles that require the bumper to be cut. Ensure cut out area is in correct position on the vehicle prior to cutting the bumper.
7. The high tensile fasteners supplied with this product were used to achieve the specified rating. If replacement is required ensure that fasteners of the same rating & quality are used. Contact an authorized **Trailboss** dealer if further information is required.
8. Ensure that all hardware is fastened to torque list below check fasteners on regular basis.
9. Tow bar load rating sticker provided with this product shall be conspicuously located on inside rear end of the driver's door. **(See diagram below)**.
10. Trailboss recommends that you check your tow ball to ensure that it complies with the Australian standards **AS 4177.2**.
11. **PLEASE NOTE:** It is advised to remove your LUG or TBM when not actually towing so as to produce a clear view of the vehicles registration plate if obscured, and to also provide maximum available departure angle

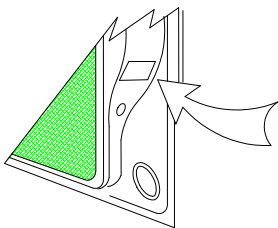

Place load rating sticker  
inside driver's door here

**FOR TRAILER TOWING PURPOSES ONLY**  
For towing capacity details please refer to vehicle owner's manual or to the manufacturer. Overloading can void your warranties.

## RECOMMENDED ASSEMBLY TORQUE LISTING

Diameter	Grade 8.8 Bolt
M6	9.5 Nm
M8	21.7 Nm
M10	43.4 Nm
M12	77.3Nm
M14	146 Nm
M16	189.8 Nm

## Tow bar Maintenance and Care.

Trailboss recommends that bolt torque's, as listed below, are routinely and regularly inspected and checked for correct tension. Replace any worn or defective parts.

We recommended to remove Tow Ball Mounts (TBM's, tongues or lugs) when not being used for any considerable length of time.

So as to avoid injury, when not towing it is suggested that the tongue, Pull Pin and R-clip are removed then stored in a safe, clean and dry place, away from excessive moisture.

Hitch Pull Pins and spring "R" clips are regularly checked for proper installation. Replace any worn or defective parts.

**Cequent Customer Service**  
Ph: 1800 812 017 Fax: 03 9898 3299  
Email: [info@cequent.com.au](mailto:info@cequent.com.au)  
Post: PO Box 4050, Dandenong South VIC 3175

# TRAILBOSS

Towbar Fitting Instructions  
 To Suit **TOYOTA CHR NXG10R/NXG50R CL2**  
 Part Number **TT165L**  
 Rating **1100/110 kg**

PLACE THESE INSTRUCTIONS IN THE VEHICLE'S GLOVEBOX AFTER INSTALLATION IS COMPLETED

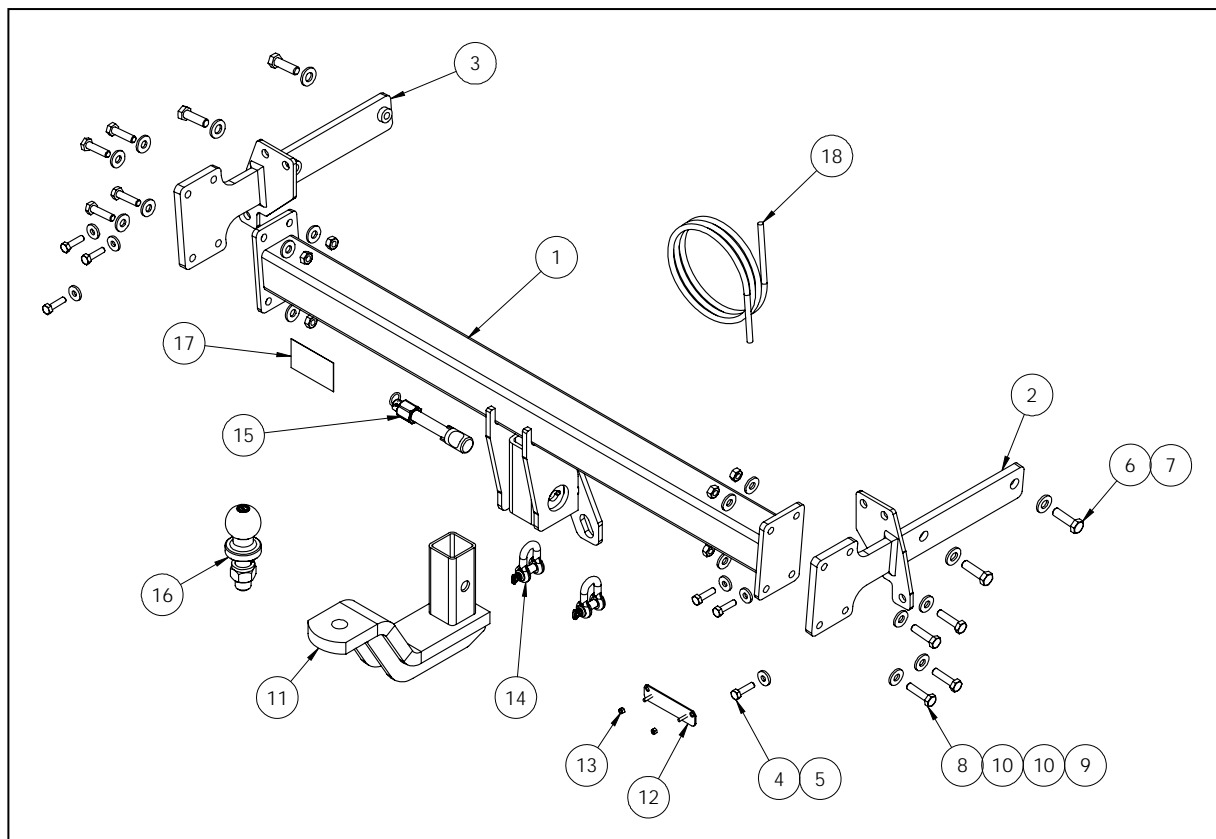

ITEM	DESCRIPTION	QTY
1	TOYOTA CHR WELDED ASSY	1
2	SIDEARM RHS	1
3	SIDEARM LHS	1
4	SET SCREW HEX HD M8x30x1.25P	6
5	WASHER PLAIN M8x22x3	6
6	BOLT M12-1.25 x40	4
7	WASHER PLAIN 1/2x1-11/8x16G	4
8	SET SCREW M10x1.25x40	8
9	NUT HX M10-1.25 Z/P	8
10	WASHER FT M10x25.4x3	16
11	TBM ASSY	1
12	VE PLUG BRACKET	1
13	NUT NYLON LOCK HEX HD M4x0.7P	2
14	10MM "D SHACKLE"	2

ITEM	DESCRIPTION	QTY
15	ANTI RATTLE PULL PIN ASSY SILVER	1
16	TOWBALL 50MM CR 3500KG PRO	1
17	COMPLIANCE LABEL	1
18	WIRING LOOM	1

**Cequent Customer Service**  
 Ph: 1800 812 017 Fax: 03 9898 3299  
 Email: [info@cequent.com.au](mailto:info@cequent.com.au)  
 Post: PO Box 4050, Dandenong South VIC 3175

# TRAILBOSS

Towbar Fitting Instructions  
To Suit **TOYOTA CHR NXG10R/NXG50R CL2**  
Part Number **TT165L**  
Rating **1100/110 kg**

PLACE THESE INSTRUCTIONS IN THE VEHICLE'S GLOVEBOX AFTER INSTALLATION IS COMPLETED

1. Under bumper on RH side, remove 2 x scrivets.

Repeat for LH side.



2. On RH wheel arch skirting, remove 2 x Screws and 1 x Scrivet.

Repeat for LH side.



3. Peel away the wheel arch skirt, secured with 4 x plastic clips (push upwards from inside the bumper).

Repeat for other side.



**Cequent Customer Service**  
Ph: 1800 812 017 Fax: 03 9898 3299  
Email: [info@cequent.com.au](mailto:info@cequent.com.au)  
Post: PO Box 4050, Dandenong South VIC 3175

# TRAILBOSS

Towbar Fitting Instructions  
To Suit **TOYOTA CHR NXG10R/NXG50R CL2**  
Part Number **TT165L**  
Rating **1100/110 kg**

PLACE THESE INSTRUCTIONS IN THE VEHICLE'S GLOVEBOX AFTER INSTALLATION IS COMPLETED

4. In wheel arch housing, remove 2 x plastic scrivet.

Repeat for other side.



5. Open tailgate and lift tab to reveal screw.  
Remove screw

Repeat for other side.



6. Remove bumper by peeling away from the wheel arches.

Ensure to disconnect wiring harness located on the LH side above the impact beam.



Set aside in a safe location.

**Cequent Customer Service**  
Ph: 1800 812 017 Fax: 03 9898 3299  
Email: [info@cequent.com.au](mailto:info@cequent.com.au)  
Post: PO Box 4050, Dandenong South VIC 3175

# TRAILBOSS

Towbar Fitting Instructions  
To Suit **TOYOTA CHR NXG10R/NXG50R CL2**  
Part Number **TT165L**  
Rating **1100/110 kg**

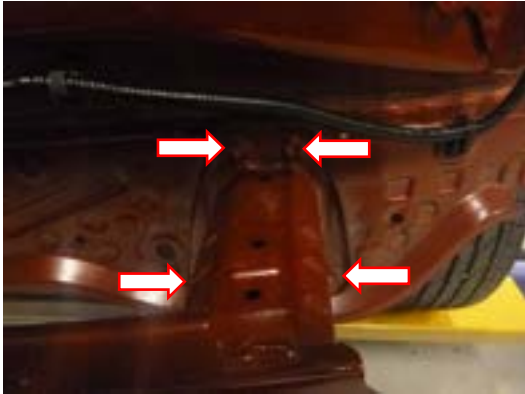
PLACE THESE INSTRUCTIONS IN THE VEHICLE'S GLOVEBOX AFTER INSTALLATION IS COMPLETED

<p>7. Remove impact beam, secured with 8 x screws (4 x RH side and 4 x LH side).</p>	
<p>8. Remove plastic plug from chassis rail (squeeze clips from inside chassis rail).  Repeat for other side.</p>	
<p>9. On the side of the chassis rail, scrape away the sealant in the appropriate position to expose the second mounting hole.  Repeat for other side</p>	

**Cequent Customer Service**  
Ph: 1800 812 017 Fax: 03 9898 3299  
Email: [info@cequent.com.au](mailto:info@cequent.com.au)  
Post: PO Box 4050, Dandenong South VIC 3175

# TRAILBOSS

Towbar Fitting Instructions  
To Suit **TOYOTA CHR NXG10R/NXG50R CL2**  
Part Number **TT165L**  
Rating **1100/110 kg**

PLACE THESE INSTRUCTIONS IN THE VEHICLE'S GLOVEBOX AFTER INSTALLATION IS COMPLETED

10. Insert RH side arm into chassis rail and loosely secure with 2 x M12 screws on the side complete with 1 x M12 washer per bolt.

Repeat for other side.



11. Loosely secure side arms to rear panel via 3 x M8 bolts complete with 1 x M8 washer per bolt.

Repeat for other side.



12. Lift cross tube up to side arms and loosely secure with 4 x M10 bolts complete with 2 x M10 washers and 1 x M10 nut per bolt.

Repeat for other side.

Tighten all fasteners to the torques listed below:

- M8- 22 N.m
- M10- 48 N.m
- M12- 89 N.m



## Cequent Customer Service

Ph: 1800 812 017 Fax: 03 9898 3299

Email: [info@cequent.com.au](mailto:info@cequent.com.au)

Post: PO Box 4050, Dandenong South VIC 3175

# TRAILBOSS

Towbar Fitting Instructions  
To Suit **TOYOTA CHR NXG10R/NXG50R CL2**  
Part Number **TT165L**  
Rating **1100/110 kg**

PLACE THESE INSTRUCTIONS IN THE VEHICLE'S GLOVEBOX AFTER INSTALLATION IS COMPLETED

13. Identify the centre of the bumper. Mark and then cut out a 40mm tall x 90mm wide rectangle, starting from the bottom edge of the bumper, as measured following the outer skin.



14. Mark out and drill 2 x Ø5mm holes 69mm apart on bumper skin to support plug bracket. Feed bracket through drilled holes prior to reinstalling bumper.

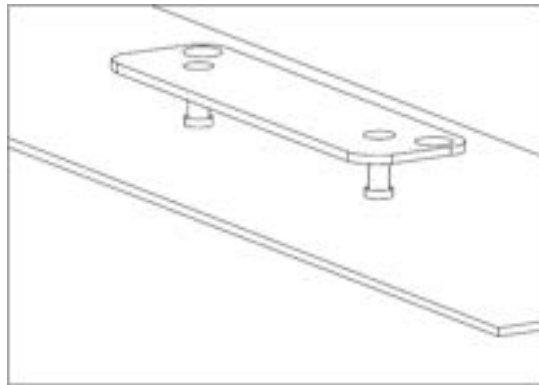

15. Re-install bumper and fasteners following steps 1-7 in reverse.

Place the instructions in the glove box after fitment.

**Cequent Customer Service**  
Ph: 1800 812 017 Fax: 03 9898 3299  
Email: [info@cequent.com.au](mailto:info@cequent.com.au)  
Post: PO Box 4050, Dandenong South VIC 3175





Wiring Loom Fitting Instructions  
To Suit Toyota C-HR  
Part Number 101764-WL

Wiring Loom Installation Instructions

Toyota C-HR  
Part No: 101764-WL

Tail Harness Length Required: 1200mm  
ECU Required: 04836

Wiring Loom Installation Time: Approx 45 Mins





Wiring Loom Fitting Instructions  
To Suit Toyota C-HR  
Part Number 101764-WL

1. In the luggage compartment, remove the rear parcel shelf and the floor cover.
2. If fitted, remove the two knobs and then remove the LHS trim access door.
3. Lift the foam tool trays upwards whilst unscrewing captive clips anti-clockwise.
4. Remove the LHS, center and RHS tool trays.
5. Remove the spare wheel.
6. Remove the two tie down hooks and then remove the rear trim.
7. Remove the luggage compartment LHS trim luggage hook.
8. Dislodge the luggage compartment LHS trim and disconnect the light connector.
9. Remove the luggage compartment LHS trim.
10. Remove the LHS rear passenger door scuff plate.
11. Dislodge the rubber door seal.
12. Dislodge the 'C' pillar lower trim.
13. Remove the 'C' pillar trim.
14. Remove the luggage compartment roof lining clips.
15. Remove the cabin light cover.
16. Dislodge the cabin light plastic piece by pushing the side tabs towards the middle.
17. Remove the LHS rear passenger handle by removing the two caps.
18. Disengage the clips from the inside and then release the handle.
19. Remove the front passenger door scuff plate.
20. Remove the plastic nut from the front LHS kick panel.
21. Remove the front LHS kick panel.
22. Dislodge the front passenger door seal.
23. Remove the LHS 'B' pillar seat belt cover and bolt.
24. Remove the LHS 'B' pillar lower trim.
25. Remove the two clips from the upper 'B' pillar trim and then remove the upper 'B' pillar trim.



Wiring Loom Fitting Instructions  
To Suit Toyota C-HR  
Part Number 101764-WL

26. Open the glove compartment.
27. Squeeze in the two posts and the pull out the damper.
28. Remove the glove compartment.
29. Push down onto the tabs and remove the glove compartment underside trim.
30. Connect the Trailer Wire Harness ECU connector to the ECU.
31. Route the Trailer Wire Harness over the LHS wheel arch.
32. Secure the Trailer Wire Harness ground ring terminal to the vehicle grounding point using the existing fastener.
33. Route the Trailer Wire Harness branch with the 20-way connectors up the LHS 'C' pillar and towards the roof lining.
34. Under the boot head liner, disconnect the head lining 20-way connector and then patch the Trailer Wire Harness 20-way connectors in between.
35. Continue routing the Trailer Wire Harness along the LHS of the vehicle, following the vehicle harness towards the front passenger kick panel area.
36. At the front passenger kick panel cavity, locate and disconnect the vehicle 20-way connectors and patch the Trailer Wire Harness -20-way connectors in between.
37. Route the Trailer Wire Harness ORANGE +12V terminal up to the IP/JB area.
38. In the glove compartment cavity, disconnect the junction block connector by lifting the lever.
39. Remove connector lever arm and release the secondary lock.
40. Insert the Trailer Wire Harness ORANGE +12V terminal into the junction block connector Pin 4 location as shown.
41. Engage the secondary lock and check that the terminal is housed correctly.
42. Refit the black lever and reconnect the junction block connector to the junction block.
43. Locate the vehicle 30A fuse location from underneath the IP/JB location.
44. Insert the supplied 30A Fuse into the location shown.
45. Inside the luggage compartment, Drill a Ø30mm hole.
46. Apply rust inhibitor (not supplied).
47. Attach trailer socket to towbar.



Wiring Loom Fitting Instructions  
To Suit Toyota C-HR  
Part Number 101764-WL

48. Route Tail Harness (tail length 1200mm) up through hole toward LHS of vehicle.
49. Connect the tail harness 8-way connector to the trailer patch mating 8-way connector.
50. Test the trailer wiring harness function using a light board or multi-meter.
51. Secure all harnesses using cable ties (not supplied).
52. Re-fit all removed parts and secure all fasteners, ensuring there are no squeaks or rattles.
53. Place the fitting instructions in the glove box after fitment.



# FITTING INSTRUCTIONS

## Silent Anti-Rattle Hitch Pin (PR0001)

• These fitting instructions are supplied to ensure understanding of how the HITCH PIN should be fitted and used correctly.

• Once installed, we recommend **ALL** instructions are kept and placed in the vehicle glove box.

**NOTE: Routine maintenance and inspection of the towbar & HITCH PIN is required. Regularly inspect for wear and check the tightness of the Hitch Pin. Follow instructions below to retighten the nut when necessary.**

**\*Do not tow with your vehicle if the R CLIP or the HITCH PIN is loose or missing. Replacement parts are available from your Pro Series Distributor.**

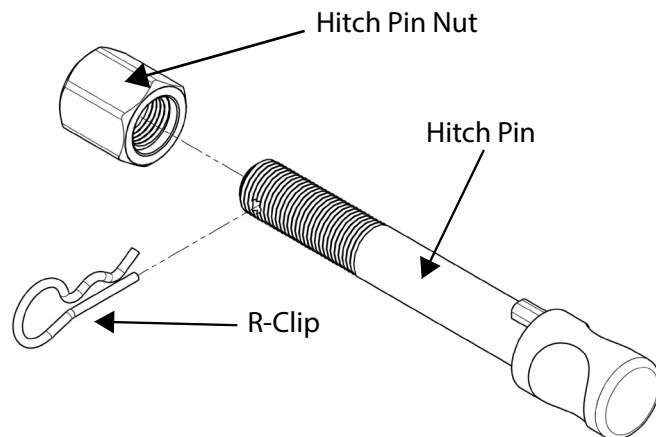

Fig 1. Silent Anti-Rattle Hitch Pin assembly

### STEP 1

Insert Trailer Ball Mount (TBM) into towbar HITCHBOX, aligning hole in TBM SHANK with hole in HITCHBOX (Fig 2).

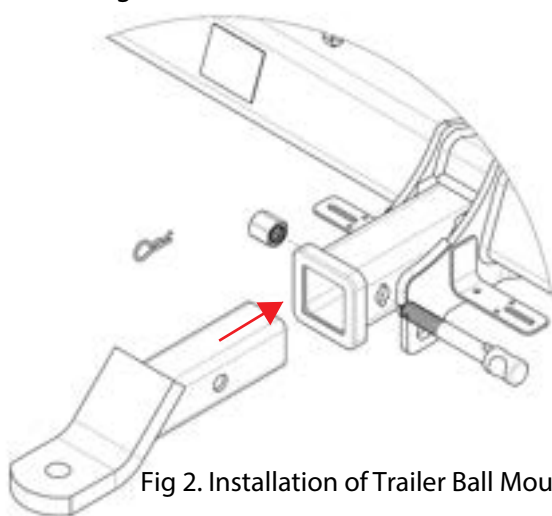

Fig 2. Installation of Trailer Ball Mount

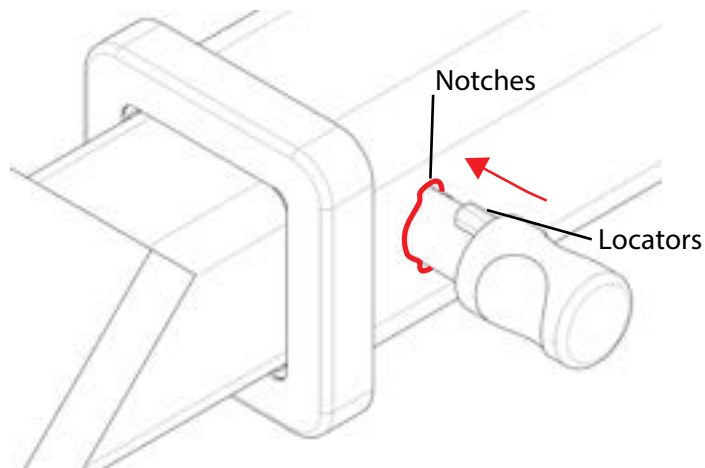

Fig 3. Silent Anti-Rattle Hitch Pin orientation

### STEP 2

Insert HITCH PIN through hole in HITCHBOX and hole in TBM SHANK; ensure the LOCATORS are inserted into the NOTCHES in the HITCHBOX (Fig. 3).

### STEP 3

Screw HITCH PIN NUT onto HITCH PIN ; tighten HITCH PIN NUT until finger tight, ensuring TBM is restrained from movement.

### STEP 4

Tighten HITCH PIN NUT by turning nut a further 1/8th of a turn in the clockwise direction using a 24mm spanner (Fig. 4).

### STEP 5

Install HITCH PIN R CLIP through the hole on the HITCH PIN (Fig. 1).

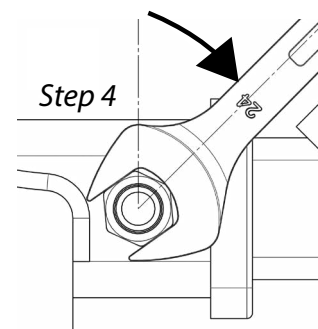

Fig 4. Tightening of Silent Anti-Rattle Hitch Pin Nut