

PRODUCT DETAILS:

Part Number:	TT167L	Maximum Towing Braked:	800	kg
ECU Number:	04826	Maximum Towing Unbraked:	750	kg
Tail Harness Length Required:	1800 mm.	Maximum Static Ball Load:	80	kg
TBM/Lug Part Number:	07755			

FITTING DETAILS:

Towbar Installation Time:	50 Mins.	RPA Disable/Other Notes:	NO
Total Installation Time:	80 Mins.		
Bumper Cut Required:	Yes		

Note:

- Electric Brake Input Location: Near blue connection.

TRAILBOSS RECOMMENDS THAT INSTRUCTIONS ARE READ AND UNDERSTOOD COMPLETELY PRIOR TO FITMENT.

BEFORE YOU START:

Check all hardware items have been included refer to assembly diagram.
Please ensure this towbar is only fitted to vehicle models as per Trailboss application guide.

Bumper Cuts

Vehicle and bumper variations can and do occur during vehicle manufacture after initial towbar design. Fitment of towbar to vehicle and accuracy of bumper cut must be assessed prior to any bumper modifications made. Incorrect bumper cuts are not covered under Trailboss warranty.

NOTE: Bumper cuts need to be approached with care, refer to notes below.

- Bumper centreline – where the centreline of the bumper needs to be determined, the installer must assess centre point by measurement of bumper width or determining two symmetrical reference points to give centreline.
- Bumper edge – To assist with accurate bumper cut measurement, reference to the start of the bumper edge is now being commonly used.
 - Measure from bottom edge along bumper and around corner to the 70 mm point (Figure 1).
 - Do not measure from visible bumper front of corner, upwards (Figure 2).

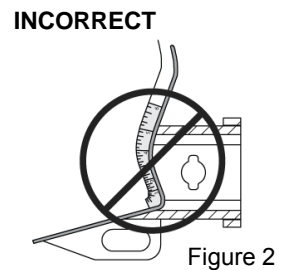
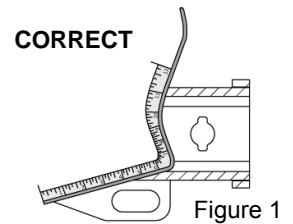

Drilling

- For any required drilling during installation, ensure that the area is clear of fuel, electrical & other components that may be damaged.
- All holes drilled into metal body panels shall have all burrs & swarf removed then coated with a suitable rust preventative paint.

Bolts/Fasteners

- Ensure that all hardware is fastened to correct torque as specified in this fitting instruction.
- All fasteners supplied with this product are used to achieve a specified clamp loading. If replacement is required ensure that fasteners of the same grade and class are used.

NOTE: Achieving correct torque is critical to proper installation and responsibility of the installer. Towbar failures attributed to tension issues from over tightening or under tightening are not covered by Trailboss warranty.

Product Labels

- a. Towbar load rating sticker provided with this product shall be conspicuously located on inside rear end of the driver's door.

WARNING:

Do not, drill, cut, weld or otherwise modify the towbar.

FOR TOWING PURPOSES ONLY - This towbar is designed and tested by Trailboss to adhere to ADR 62/02 which provides only for the expected load demands of towing.

i TOWBAR ASSEMBLY DIAGRAM

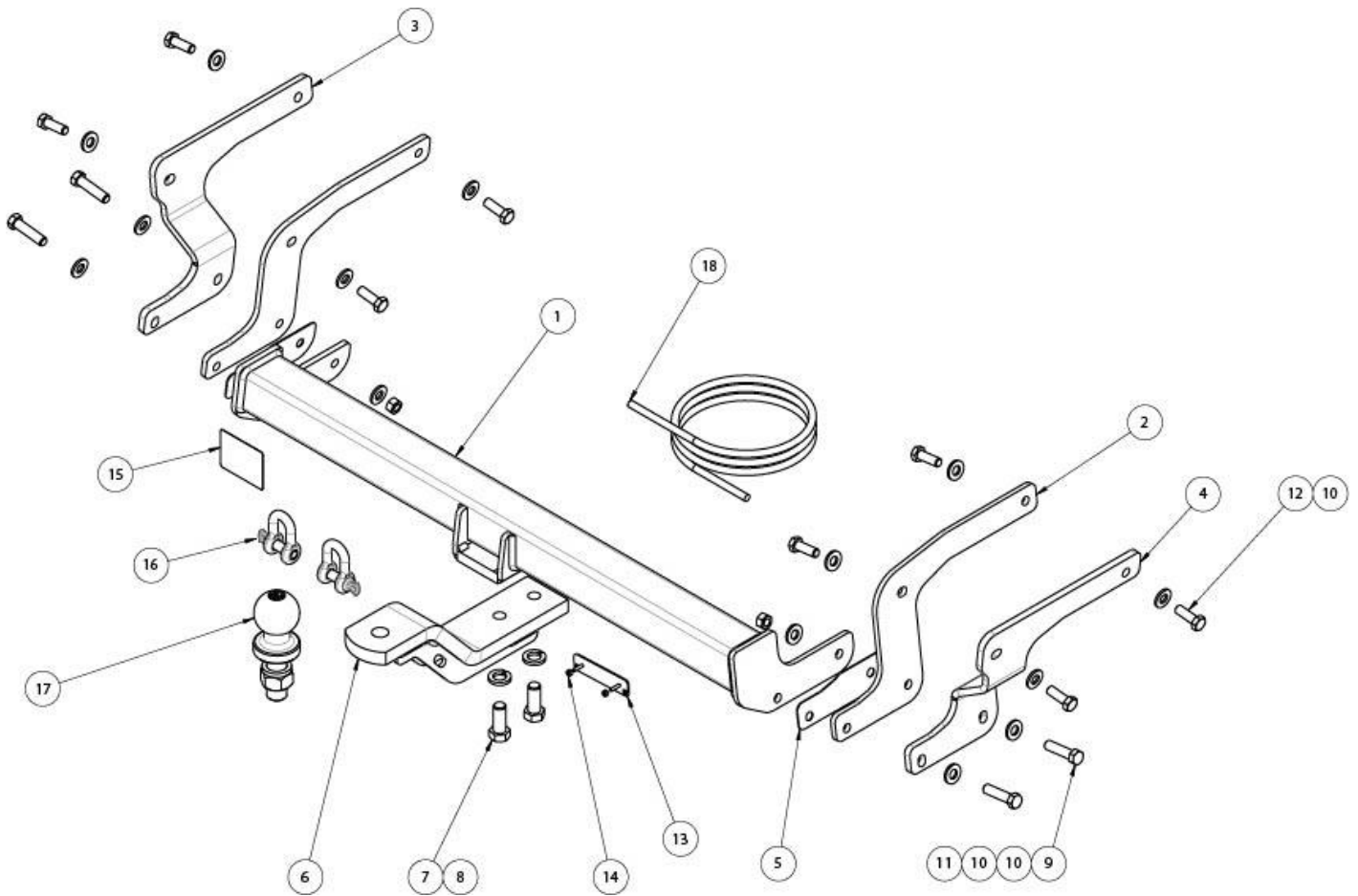

ITEM	DESCRIPTION	QTY
1	RAV 4 CL2 WELDED ASSY	1
2	INNER CHASSIS PLATE	2
3	OUTER CHASSIS BRACKET LH	1
4	OUTER CHASSIS BRACKET RH	1
5	SHIM	2
6	LUG ASSY	1
7	SET SCREW HEX HD M16x40x2.0P	2
8	WASHER SPRING M16x5x3.5	2
9	BOLT HEX HD M12x50x1.25P	4

ITEM	DESCRIPTION	QTY
10	WASHER PLAIN 1/2x1-1/8x16G	16
11	NUT HEX HD M12x1.25P	4
12	SET SCREW HEX M12x35x1.25P	8
13	PLUG BRACKET	1
14	NUT NYLON LOCK HEX M4x0.7P	2
15	ACRYLIC COMPLIANCE LABEL	1
16	"D" SHACKLE 10mm	2
17	50mm TOWBALL	1
18	WIRING LOOM	1

1. Open tailgate and remove 2 x bumper mounting screws.

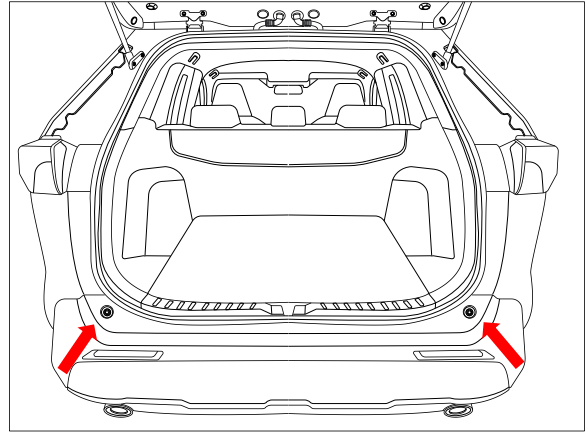

2. Remove the plastic cover by the taillights to reveal the bumper mounting screw. Remove 1 x bumper mount screw.

Repeat for other side.

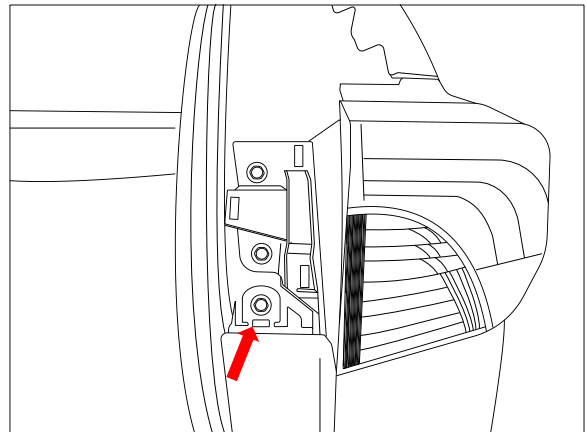

3. In wheel arch remove 1 x screw and 2 x scrivenets.

Repeat for other side

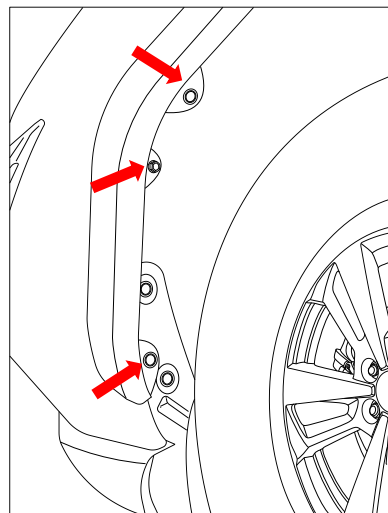

-
4. Unclip and peel away wheel arch skirting to reveal 1 x scrivet. Remove scrivet.

Repeat for other side.

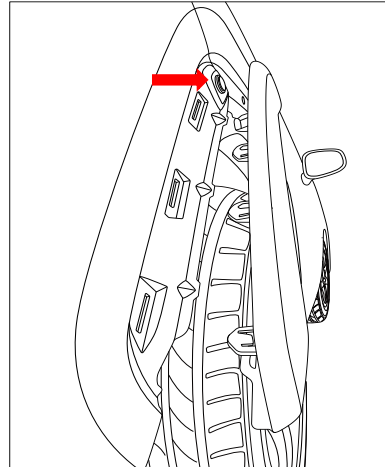

-
5. Remove 2 x screws securing mudflap to bumper.

Repeat for other side.

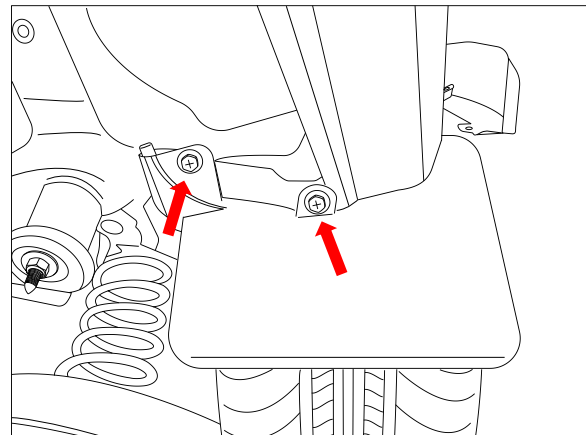

-
6. Under vehicle remove 2 x bumper tab scrivets.

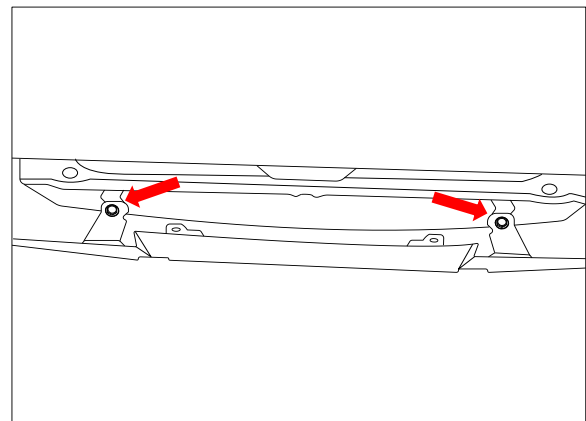

-
7. Under vehicle on LH side disconnect the wiring harness.

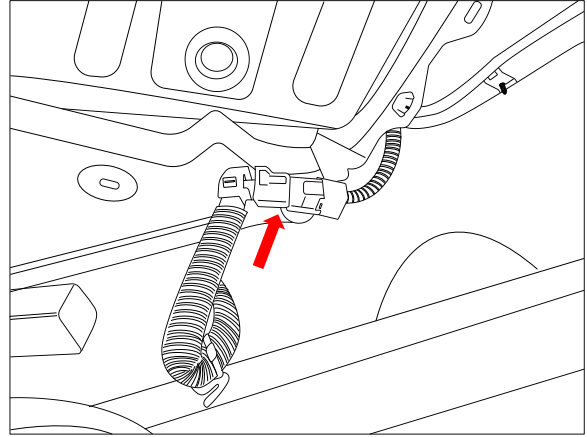

-
8. Peel away and remove bumper from the vehicle.

-
9. Loosen impact beam secured with 3 x bolts per side.

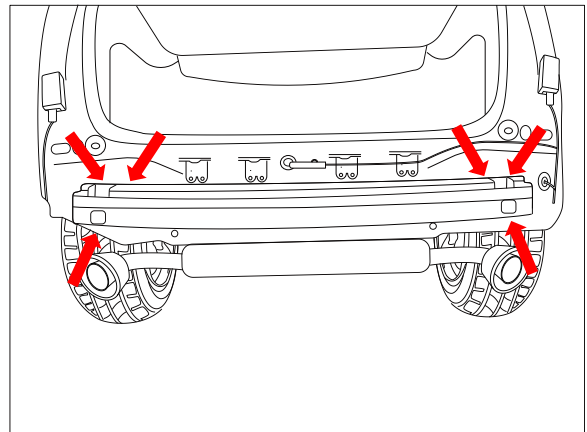

10. Under vehicle on RH side, remove and discard tow hook secured with 2 x bolts.
11. Refit the 2 x bolts in the holes and torque to 60 Nm

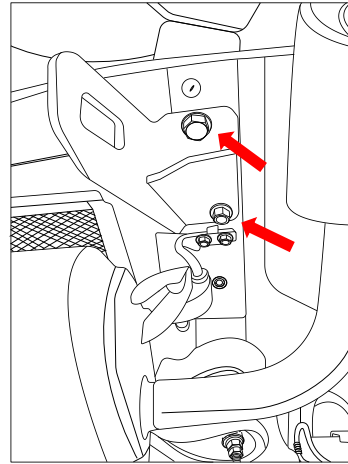

12. On the inward and outward sides of the chassis rail remove 4 x stickers to expose the M12 weld nuts.

Repeat for other side.

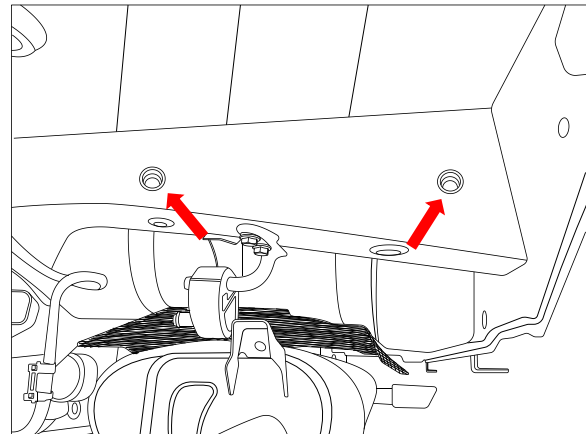

13. Loosely secure the outer chassis plate to the outside of the chassis rail with 2 x M12 x 35 bolts complete with 1 x washer per bolt.

Note: For the RH side, position the bolt and washer in the most forward hole prior to positioning the plate in position.

Repeat for other side.

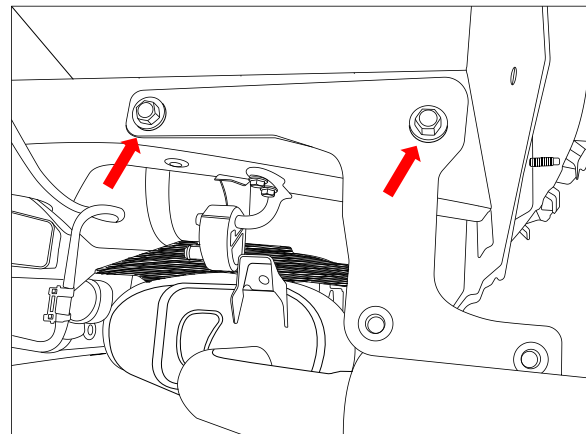

14. Loosely secure the inner chassis plate to the inside of the chassis rail with 2 x M12 x 35 bolts complete with 1 x washer per bolt.

Repeat for other side.

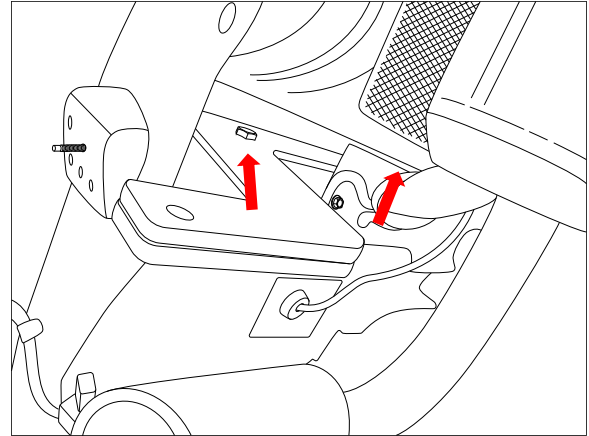

15. Hand tighten all bolts to eliminate plate looseness.
16. Lift crosstube to the side arms and loosely secure with 2 x M12 x 50 bolts complete with 2 x washers and 1 x nut per side.

NOTE: Add the provided shims (1 on LH and 1 on RH side) to eliminate excessive clearance (>3mm) should there be any between the crosstube and the side arms.

17. **Torque all fasteners to 125Nm**

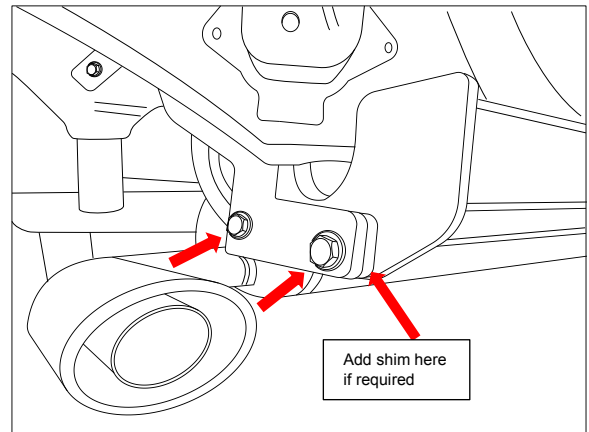

18. Reposition the impact beam away from the towbar.
Torque the 6 x impact beam mounting bolts to 60Nm.

Note: Should there be no clearance between the towbar and the impact beam, remove the impact beam along with the bolts and discard.

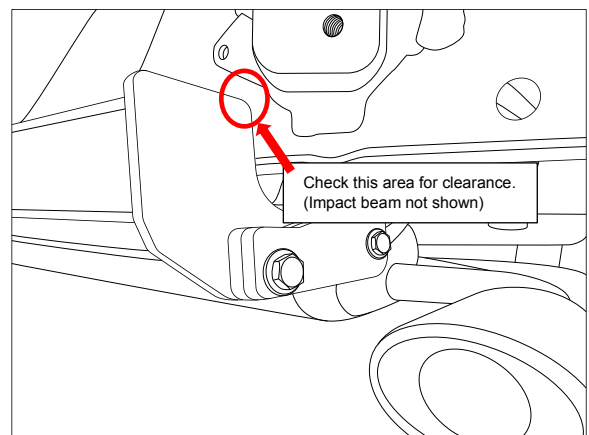

19. For bumper cut.

Determine the centre of the bumper, measure and mark off 90mm wide by 135mm long as measured from the bottom edge of the bumper.

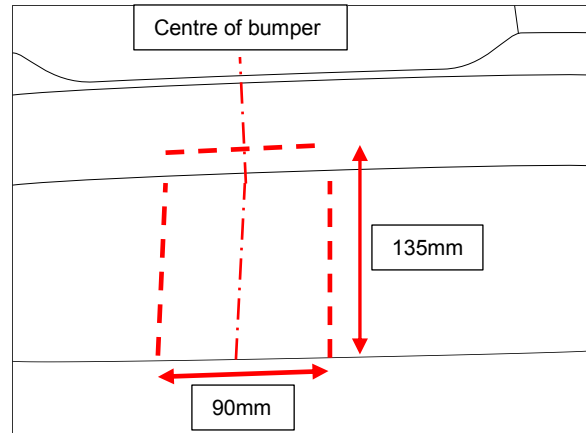

20. Mark out and drill 2x $\varnothing 5$ mm holes 69mm apart on bumper skin to support plug bracket.

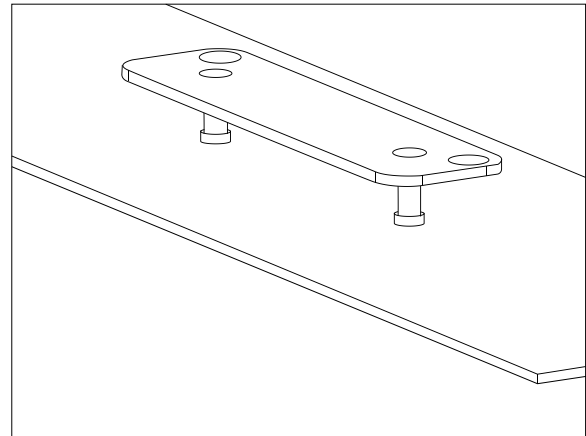

IMPORTANT

Due to possible vehicle variations, always confirm any noted vehicle colour wires with a multi-meter to ensure the correct function is identified before soldering or scotch locking. For vehicle wires denoted with two colours (example; RED/GREEN) the first colour will always be the main wire colour while the second colour is the thinner trace colour on the wire.

21. For petrol engines, in the Engine Bay, disconnect the vehicle battery negative terminal
22. For hybrid engines, in the luggage compartment disconnect the vehicle battery negative by removing the RHS trim with net (1) and the trim piece (2) directly beneath this.

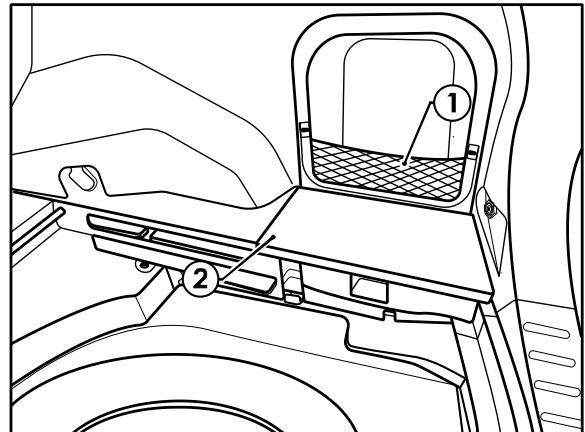

23. In the luggage compartment, remove floor cover carpet (1)
24. Remove the rear sunshade if present (2)
25. Fold the rear row seats down (3)

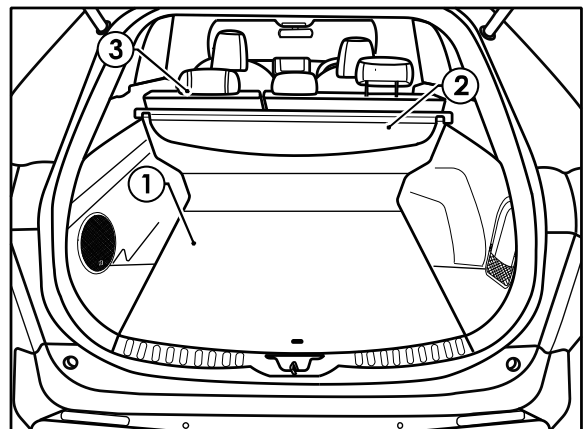

26. Remove the rear trim piece above the spare tyre (1) by removing the two 8mm screws (2).

27. Remove the rear scuff trim (3) by pulling in an upwards direction.

28. Remove the LHS trim near the subwoofer (4).

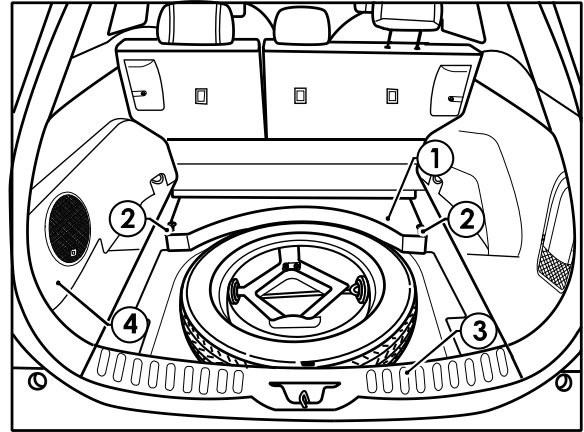

29. On the LHS luggage compartment trim, remove the two luggage hooks (1).

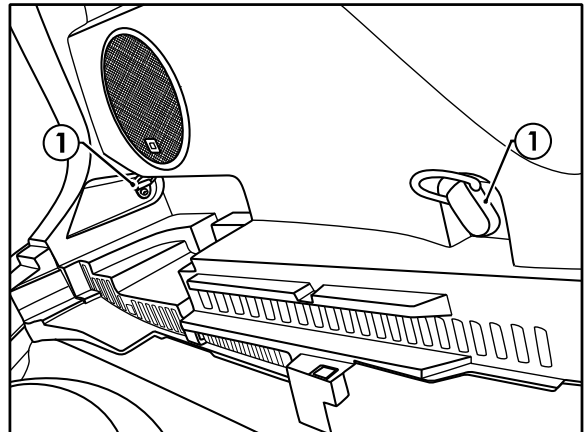

30. Remove the last screw (1) and bolt (2) securing the LHS trim (3) to the vehicle.

31. Dislodge the LHS trim.

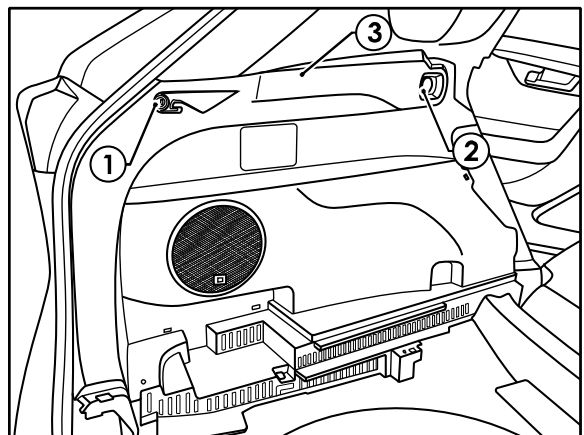

32. Locate the vehicle prewire connector (1).
33. Remove the electrical tape from the connector.
34. Plug the mating connector on the trailer patch harness (102241-WL) into the vehicle prewire connector.

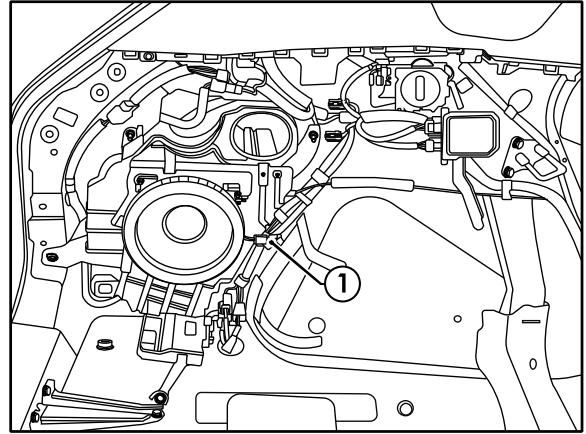

35. Using an alcohol wipe, clean the LHS inner sheet metal area (1) and the underside of the ECU (04826).
36. Connect the trailer patch 12-way connector (2) to the ECU.
37. Apply double sided tape to the ECU and secure it to the vehicle sheet metal in a suitable location.
Note: Mount the ECU, ensuring the connector is orientated downwards.

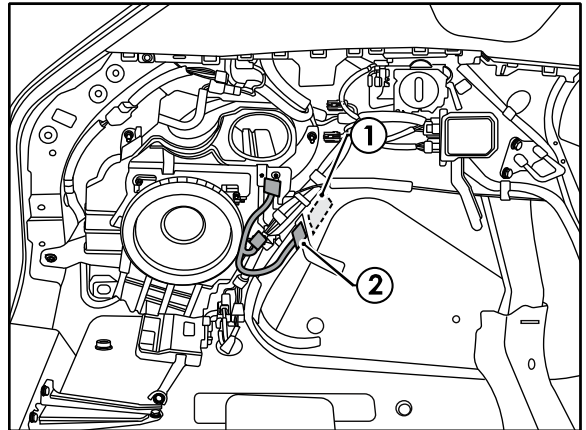

38. Connect the ground wire ring terminal to the vehicle earthing point in the D Pillar (1).
39. Remove the vehicle blanking grommet (2).

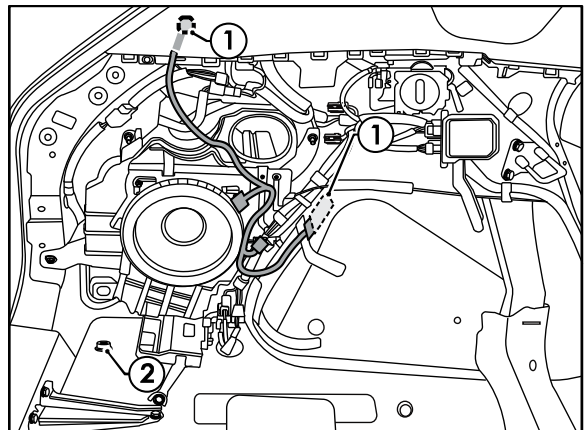

-
40. With the rear bumper removed, secure tail harness (length 1800mm) to towbar.
 41. Route tail harness up through chassis and previously removed vehicle blanking grommet.
 42. Seat grommet in 30mm blanking hole and route to trailer harness blue connector on patch loom.
Note: Keep harness routing clear of all sharp edges, moving parts and places of extreme heat.
Note: Ensure grommet is seated correctly and makes a good seal.

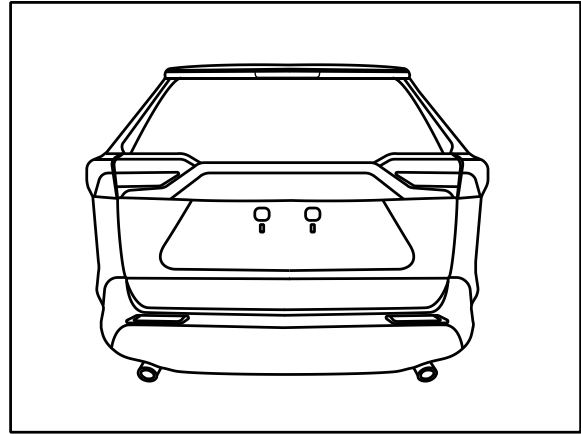

-
43. Connect the tail harness 8-way connector (1) to the trailer patch mating 8-way connector (2).
 44. Secure all harness using supplied Cable Ties.

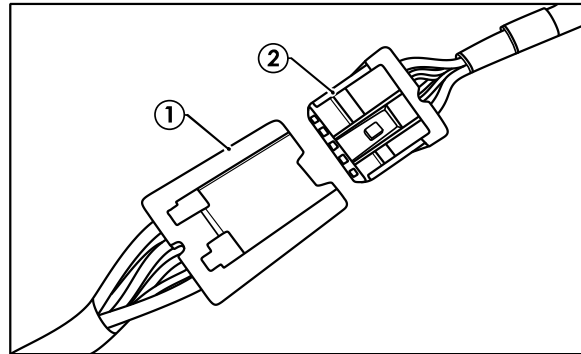

-
45. Test the trailer patch function using a light board or multi-meter.
 46. Re-fit all removed parts and secure all fasteners, ensuring there are no squeaks or rattles.
 47. Place the fitting instructions in the glove box after fitment.



CUSTOMER INFORMATION

PLACE THESE INSTRUCTIONS IN THE
VEHICLE'S GLOVEBOX AFTER INSTALLATION

**THANK YOU FOR PURCHASING TRAILBOSS. WITH CORRECT MAINTENANCE AND CARE
THIS PRODUCT WILL PROVIDE A LIFETIME OF TROUBLE-FREE OPERATION.**

TOWBAR MAINTENANCE AND CARE:

1. Trailboss recommend that the towbar LUG or TBM (Trailer Ball Mount) Pull Pin and R-clip are removed and stored when not in use. Removal of LUG or TBM (Trailer Ball Mount) is advisable when not in use to assist with any of the following.
 - Ensure rear number plate is not obscured.
 - Allow maximum available departure angle and prevent any potential interference.
 - Prevent possible interference with vehicles reverse sensors or camera detecting a tow ball mount as an obstruction during reversing.
 - Removes towball mount as an obstruction for when moving around the rear of the vehicle.
2. Trailboss recommends routine inspection of your towbar to ensure trouble free towing.
 - Bolt security and tension should be regularly inspected and checked for correct tension. Replace any worn or defective parts with suitable grade & class fasteners. Inspection should be requested to coincide with vehicle major services.
3. It is the owner's responsibility to ensure towing and down ball weight capacities of the towing vehicle are not exceeded.
 - Towing and down ball weights allowable may differ according to model variations. Please refer to owner's manual or vehicle dealer to confirm exact rating for your vehicle model variant.
 - It is not uncommon for the vehicle tow rating to differ from the towbar rating. When this occurs, the lesser rating must be adhered to.
 - For vehicles fitted with enhanced vehicle functions that may be altered/changed when towing i.e Trailer sway mitigation, blind spot detection, adaptive cruise control etc. Please consult owner's manual to understand changes enabled when towing and after towing.

WARRANTY INFORMATION:

Trailboss Towbars are covered by a Lifetime Warranty.

Our goods come with guarantees that cannot be excluded under the Australian Consumer Law. You are entitled to a replacement or refund for a major failure and for compensation for any other reasonably foreseeable loss or damage. You are also entitled to have the goods repaired or replaced if the goods fail to be of acceptable quality and the failure does not amount to a major failure.

For further details please contact customer service on 1800 812 017.

PRO SERIES SILENT ANTI-RATTLE HITCH PIN

Your Trailboss towbar is equipped with a Pro Series Silent Anti-Rattle Hitch Pin technology to help reduce towbar tongue rattle in most driving conditions. Please ensure below instructions are understood and routine maintenance is carried out to ensure best towing experience.

Regularly inspect for wear and check the tightness of the Silent Anti-Rattle Hitch Pin. Follow instructions below to re-tighten the nut as necessary when movement and noise in the tow ball mount is noted.

- Before towing, ensure R-Clip is properly installed and hitch pin nut is installed and tensioned. Replacement parts are available from your Pro Series Distributor.

TOWBALL MOUNT REMOVAL/INSTALLATION

STEP 1

Insert Trailer Ball Mount (TBM) (a) into towbar hitchbox (b), aligning hole in TBM shank (c) with hole in hitchbox (d) (Fig. 1)

STEP 2

Insert Silent Anti-Rattle Hitch Pin (e) through hole in hitchbox and hole in TBM shank (g); ensure the locators are inserted into the notches in the hitchbox (Fig. 2)

STEP 3

Screw Silent Anti-Rattle Hitch Pin (f) onto Smart Pin (g); tighten Smart Pin Nut until finger tight, ensuring TBM is restrained from up and down movement.

STEP 4

Tighten Silent Anti-Rattle Hitch Pin Nut by turning nut a further 1/8th of a turn in the clockwise direction using a 24mm spanner (Fig. 4).

STEP 5

Install Silent Anti-Rattle Hitch Pin R-Clip through the hole that provides best clearance or easiest access. (Fig. 5)

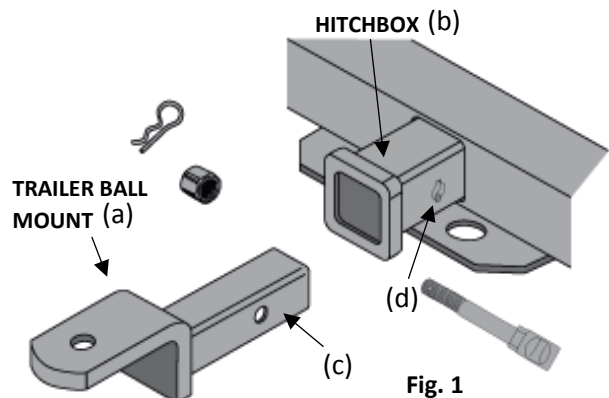

Fig. 1

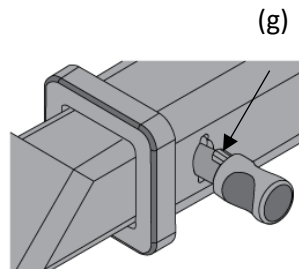

Fig. 2

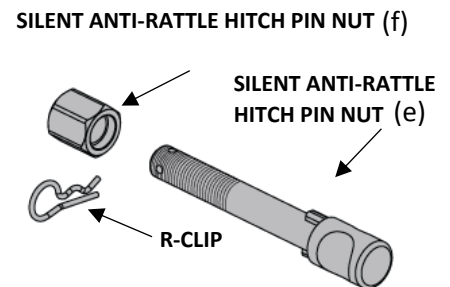

Fig. 3

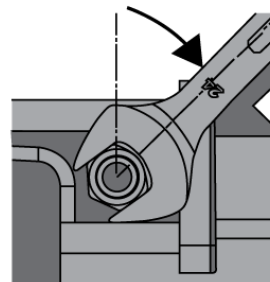

Fig. 4

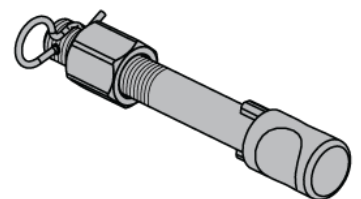

Fig. 5