

TRAILBOSS

Towbar Fitting Instructions
To Suit **VOLKSWAGEN GOLF 7 WAGON 08-13-ON**
Part Number **VW23L**
Rating **1200/75 kg**

PLACE THESE INSTRUCTIONS IN THE VEHICLE'S GLOVEBOX AFTER INSTALLATION IS COMPLETED

WARNING:

1. Do not, drill, cut, weld or otherwise modify the tow bar.
2. If you are using electric welding on a motor vehicle, **always** check that the vehicle is not equipped with electronic engine or instrument management equipment. Failure to do so could **destroy** any onboard computers. If in doubt, check with the vehicle's manufacturer.
3. The high tensile fasteners supplied with this product were used to achieve the specified rating. If replacement is required ensure that fasteners of the same rating & quality are used. Contact an authorised **Trailboss** dealer if further information is required.
4. If TBM is used in inverted position tow ball may make contact with rear tailgate when lowered, which could cause damage.

General:

1. Ensure all hardware items have been included refer to assembly diagram.
2. It is recommended that the instructions are read through and completely understood before making any attempt to fit this product.
3. Be wary of any changes to vehicle designs or other accessories that may conflict with the installation of this product.
4. Before drilling ensure that the area is clear of fuel, electrical & other components.
5. All holes drilled into the body panels shall have all burrs & swarf removed then coated with a suitable rust preventative paint.
6. For vehicles that require the bumper to be cut. Ensure cut out area is in correct position on the vehicle prior to cutting the bumper.
7. The high tensile fasteners supplied with this product were used to achieve the specified rating. If replacement is required ensure that fasteners of the same rating & quality are used. Contact an authorized **Trailboss** dealer if further information is required.
8. Ensure that all hardware is fastened to torque list below check fasteners on regular basis.
9. Tow bar load rating sticker provided with this product shall be conspicuously located on inside rear end of the driver's door. **(See diagram below).**
10. Trailboss recommends that you check your tow ball to ensure that it complies with the Australian standards **AS 4177.2**.
11. **PLEASE NOTE:** It is advised to remove your lug or tbn when not actually towing so as to produce a clear view of the vehicles registration plate if obscured, and to also provide maximum available departure angle
12. Pull Pin must be fit in down position.

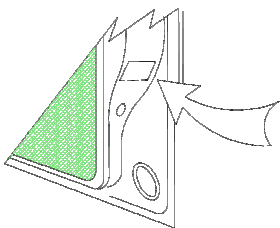

Place load rating sticker
inside driver's door here

FOR TRAILER TOWING PURPOSES ONLY
For towing capacity details please refer to vehicle owner's manual or to the manufacturer. Overloading can void your warranties.

RECOMMENDED ASSEMBLY TORQUE LISTING

Diameter	Grade 8.8 Bolt
M6	9.5 Nm
M8	21.7 Nm
M10	43.4 Nm
M12	77.3Nm
M14	146 Nm
M16	189.8 Nm

Tow bar Maintenance and Care.

Trailboss recommends that bolt torque's, as listed below, are routinely and regularly inspected and checked for correct tension. Replace any worn or defective parts.

We recommended to remove Tow Ball Mounts (TBM's, tongues or lugs) when not being used for any considerable length of time.

So as to avoid injury, when not towing it is suggested that the tongue, Pull Pin and R-clip are removed then stored in a safe, clean and dry place, away from excessive moisture.

Hitch Pull Pins and spring "R" clips are regularly checked for proper installation. Replace any worn or defective parts.

TRAILBOSS

Towbar Fitting Instructions
 To Suit **VOLKSWAGEN GOLF 7 WAGON 08-13-ON**
 Part Number **VW23L**
 Rating **1200/75 kg**

PLACE THESE INSTRUCTIONS IN THE VEHICLE'S GLOVEBOX AFTER INSTALLATION IS COMPLETED

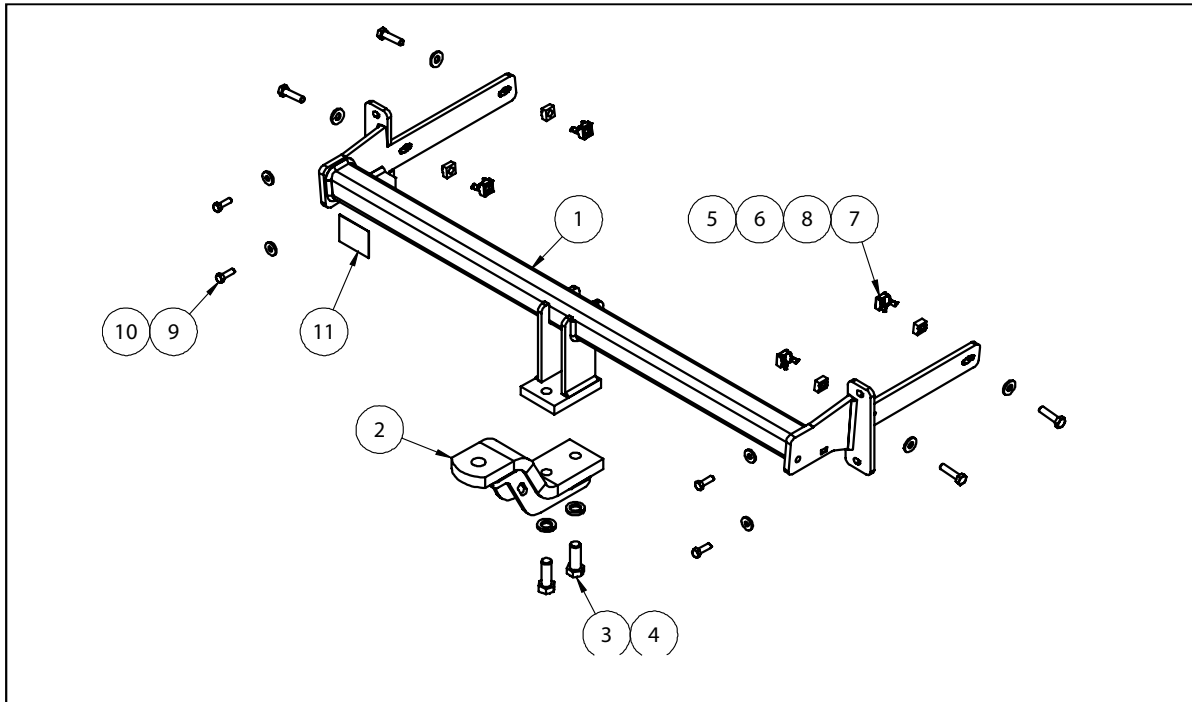

QTY	DESCRIPTION	ITEM NO
1	WELDED ASSEMBLY	1
1	LUG ASSEMBLY	2
2	BOLT M16x45 2.0P	3
2	SPRING WASHER M16x5x3.5	4
4	BOLT M10-1.5 x40mm	5
4	WASHER FT M10x25.4x3	6
4	CAGE NUT RETAINER	7
4	CAGE NUT M10x1.5	8
4	SET SCREW M8x25	9
4	FLAT WASHER M8x22x3.3mm	10
1	ACRYLIC COMPLIANCE PLATE	11

ADDITIONAL ITEMS

WIRING LOOM FITTING INSTRUCTION LR LABEL

PLUG BRACKET NUT NYLOC



Towbar Fitting Instructions
To Suit **VOLKSWAGEN GOLF 7 WAGON 08-13-ON**
Part Number **VW23L**
Rating **1200/75 kg**

PLACE THESE INSTRUCTIONS IN THE VEHICLE'S GLOVEBOX AFTER INSTALLATION IS COMPLETED

INSTRUCTION:

1. Remove 4 off Screws in rear wheel arch. Repeat for opposite side of vehicle.
2. Remove 3 off Screws and 1 off Scrivet from bumper trim under right side of vehicle.
3. Remove 1 off Screw and 1 off Scrivet from bumper trim under left side of vehicle.
4. Remove 2 off Scrivets from bumper trim under rear of vehicle.
5. Unplug tail lights and remove Screw securing tail light in place. Remove tail lights.
6. Unclip and remove Bumper Skin, disconnecting the parking sensor loom.
7. Detach muffler from Exhaust Hanger.
8. Unscrew rear muffler mount and gently lower exhaust.
9. Unscrew 3 off rear exhaust heat shield Clips and lower heat shield away from chassis rail.
10. Remove and discard 3 off Screws from impact beam on LHS of vehicle and 4 off Screws from impact beam on RHS of vehicle. Remove and discard impact beam.
11. Install cage Nuts onto side arms in the 4 profiles holes.
12. Place Towbar inside chassis rails. Loosely secure Towbar to side of chassis rail with two M10 x 40 Bolts. Loosely secure Towbar to rear panel with two M8 x 25 Set Screws. Repeat for opposing side of vehicle. Tighten all fasteners to torque specified on page 1.
13. Make cut through bumper 80mm wide, starting the cut from the LHS of the bumper window.
14. Refit bumper skin by following steps 1-9 in reverse order.





Wiring Loom Fitting Instructions
To Suit Volkswagen Golf Wagon MY14
Part Number 101196-WL

Wiring Loom Installation Instructions

Volkswagen Golf Wagon MY14
Part No: 101196-WL

Tail Harness Length Required: 1800mm
ECU Required: 04838

Wiring Loom Installation Time: Approx 30 Mins

 Important	Due to possible vehicle variations, always confirm any noted vehicle colour wires with a multi-meter to ensure the correct function is identified before soldering or scotch locking.
 Important	For vehicle wires denoted with two colours (example: RED/GREEN) the first colour will always be the main wire colour while the second colour is the thinner trace colour on the wire.

Wiring Loom Fitting Instructions To Suit Volkswagen Golf Wagon MY14 Part Number 101196-WL

1. Remove the rear sunshade and floor carpet from the luggage compartment.
2. Remove the rear compartment trim.
3. On the LHS of the luggage compartment, remove the screw behind the handle.
4. Remove the cargo clip.
5. Remove the access panel.
6. Dislodge the LHS luggage compartment trim.

Repeat for the RHS.

7. On the LHS of the luggage compartment, drill a 30mm grommet hole (1) in a suitable location.



8. On the LHS of the luggage compartment, following the table below, connect the ezy-taps to the corresponding vehicle wires, then connect the trailer patch terminals to the ezy-taps.

Function	Trailer Patch	Vehicle Connector
L.IND	YELLOW / BLACK	BLACK / WHITE
REVERSE	BLACK / WHITE	BLACK / BLUE
TAIL/BRAKES	RED / BLACK	BLACK / RED

Note: Discard BROWN / BLACK wire on the harness.

9. On the LHS of the rear quarter panel, secure the trailer patch ring terminal to the vehicle grounding point.
10. Apply double sided tape to the ECU (04838) and adhere it to the behind vehicle sheet metal on the LHS of the luggage compartment in a suitable location.

Note: Ensure when mounting the ECU the connector is facing downwards.

11. Connect the trailer patch 12-way connector to the ECU(04838).

Wiring Loom Fitting Instructions To Suit Volkswagen Golf Wagon MY14 Part Number 101196-WL

12. On the LHS of the luggage compartment, locate and solder the ORANGE power harness wire (1) to the vehicle RED / PURPLE wire (2).

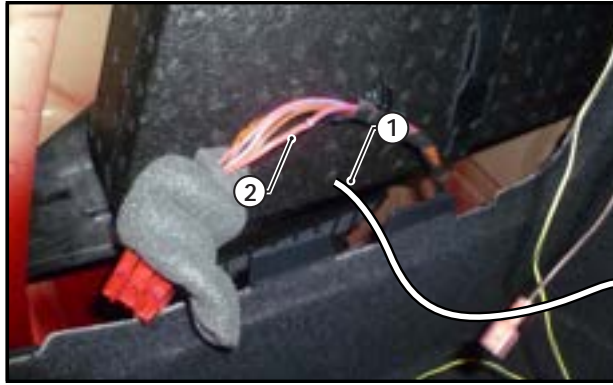

Function	Trailer Patch	Vehicle Connector
12V+	ORANGE	RED / PURPLE

13. Route the trailer harness towards the RHS of the vehicle tail light.
14. On the RHS of the luggage compartment, following the table below, connect the ezy-tap to the corresponding vehicle wire, then connect the trailer patch terminal (3) to the ezy-tap.

Function	Trailer Patch	Vehicle Connector
R.IND	GREEN / BLACK	BLACK / GREEN

15. Mount the trailer socket to the tow bar mounting bracket using M4 fasteners (not supplied).
16. Route the tail harness across the tow bar towards the LHS of the vehicle and up through the previously drilled out hole.
17. Ensure the tail harness grommet is seated correctly and secure in place using a cable tie (not supplied).
18. Connect the tail harness (tail length 1800mm) 8-way connector to the trailer patch mating 8-way connector.
19. Test the trailer patch function using a light board or multi meter.
20. Secure all harnesses using cable ties (not supplied).
21. Re-fit all removed parts and secure all fasteners, ensuring there are no squeaks or rattles.
22. Place the fitting instructions in the glove box after fitment.